

The background of the cover is a light-colored, textured surface scattered with various origami projects. There are several hearts in shades of red and orange, some of which are attached to yellow envelopes or ribbons. One envelope is open, showing a red heart inside. Another is a simple red heart with a yellow triangular piece on top. A large orange heart is positioned behind the title. A yellow envelope with a red heart is in the bottom center. A red heart with a yellow star-like pattern is in the bottom right. A red heart with a yellow ribbon is in the top left. A red heart with a yellow ribbon is in the top right. A red heart with a yellow ribbon is in the middle right. A red heart with a yellow ribbon is in the middle left. A red heart with a yellow ribbon is in the bottom left.

*ORIGAMI  
Hearts*

*by Francis Ow*

\$ 15.00



ISBN 0-87040-957-3



Japan Publications

Printed in Singapore

9 780870 409578

# ORIGAMI Hearts

Sep-14/01  
Para un niño muy  
especial, y que quiero  
mucho; espero que  
aproveches este libro  
con tus grandes  
capacidades y amor  
por las cosas que  
haces.

Yate TEATRO

by Francis Orw

© 1995 by Francis M. Y. Ow

All rights reserved, including the right to reproduce this book or portions thereof in any form without the written permission of the publisher.

Book design by Momoyo Nishimura

Published by Japan Publications Trading Co., Ltd.,  
1-2-1, Sarugaku-cho, Chiyoda-ku, Tokyo, 101 Japan

First edition, First printing: January 1996

Distributors:

United States: Kodansha America, Inc., through Farrar, Straus & Giroux,  
19 Union Square West, New York, NY 10003.

Canada: Fitzhenry & Whiteside Ltd.,  
195 Allstate Parkway, Markham, Ontario L3R 4T8.

British Isles and European Continent: Premier Book Marketing Ltd.,  
1 Gower Street, London WC1E 6HA.

Australia and New Zealand: Bookwise International,  
54 Crittenden Road, Findon, South Australia 5023.

The Far East and Japan: Japan Publications Trading Co., Ltd.,  
1-2-1, Sarugaku-cho, Chiyoda-ku, Tokyo, 101 Japan

10 9 8 7 6 5 4 3 2 1

ISBN: 0-87040-957-3

Printed in Singapore

## *Acknowledgements*

This book is not possible without the help of the many dedicated paperfolders, whom I am proud to have as friends.

David Petty, my regular correspondent in England and also an active member of the British Origami Society, has played a major role in this book, although only three of his models are included in this book, Petty has contributed by boosting my creative abilities, especially in times when I needed it most. Both he and his wife, Lilian, have supplied countless subjects relating to hearts. Models like "Baby Love", "Sweet Heart", "Love is Blind" and many others are the results of their brainstorming.

Paul Ee, my comrade, provided six of his excellent creations which I am proud to include in this book.

To the rest who have contributed, namely, Nick Robinson and Edwin Corrie of the British Origami Society, Francois Ziegler of France, Edwin Young of the U.S.A., Kunihiro Kasahara and Jun Maekawa of Japan, I offer my heartfelt thanks for all their excellent models.

My thanks to Eunice Lew of the U.S.A. for proofreading and for supplying diagrams of heart models by various paperfolders. My apologies for not including any, as some are similar, some too complicated and a few which I would like to include in this book but could not obtain permission from the creators.

I wish also to thank the Momotani family, Dokuotei Nakano of Japan and Vicent Palacios of Spain for their generous assistance.

I would especially like to extend my gratitude to Tomoko Fuse for introducing my works, not only to Japan but also to her publisher, Japan Publications Trading Co., Ltd., Tokyo, Japan.

My thanks to Yunosuke Murakami of Japan Publications Trading Co., Ltd. for his interest in my works and for publishing this book.

This book is dedicated to all my friends and all those mentioned here.

Francis M. Y. Ow.

## LIST OF ILLUSTRATIONS

<i>Photo page</i>	<i>Instruction page</i>	<i>Photo page</i>	<i>Instruction page</i>
<i>Front Cover</i>		<i>Page 12</i>	
Heart Ring 2	Page 42	No.34 Heart Module 1	Page 17
Love Boxes	60	35 Sweet Heart	59
Love is Blind	104	36 Heart Cube Module	28
On a Stand	54	37 Box	51
Book Marker	95	38 2-Piece Heart Coaster	118
House of Love	111	39 Heart Tatou	76
Flowery Heart	62	40 Coaster	49
Heart Envelope	57	<i>Page 27</i>	
3-D Heart (Petty's)	83	41 Heart Module 3	20
<i>Page 5</i>		42 Index Marker	21
No.1 A Gift of Love	40	43 Heart Module 5	25
2 Love Dove	92	44 Heart Module 4	22
3 Flowery Heart	62	45 Love Triangle	33
4 Windmill on Heart	67	46 Photo Frame with Hearts	38
5 Love Birds	91	47 Heart on Heart	44
<i>Page 6</i>		48 Bigamous	43
6 Lover's Hat	44	<i>Page 53</i>	
7 Love is Blind	104	49 Half-Hearted	46
8 Heart Brooch	86	50 Pockets for Half-Hearted	47
<i>Page 7</i>		51 Coaster	49
9 Heart Pin	78	52 A Better Half	48
10 Love Cap	45	<i>Page 79</i>	
11 Heart Ring 2	42	53 2's Company, 3's a Crowd	55
12 Heart Ring 3	95	54 Loving Pajaritas	73
13 A Gift of Love	40	55 Falling in Love	54
<i>Page 8</i>		56 4's Too Many, 8's an Orgy	56
14 Love on the Rock	52	57 Puppy Love	71
15 Heart Corner Marker 2	97	58 Heart Module 6	82
16 Heart Corner Marker	96	59 Heart ["Fuse"Lock]	64
17 Heart Envelope	57	60 Baby Love	69
18 Dutch Valentine Card	50	61 Double Sided Heart	80
<i>Page 9</i>		<i>Page 99</i>	
19 Heart Tangram	101	62 3-D Heart	83
20 Index Marker	21	63 Head Over Heels	84
21 Book Marker	95	64 A Heart for Two	90
22 Heart Frame	31	65 Twin Hearts with Stand	98
<i>Page 10</i>		66 Circle of Heart[Module]	94
23 Flying Heart	89	67 Changing Heart	100
24 Love on the Rock	52	68 Heart 2	109
25 Winged Heart	87	69 Heart 4	117
26 Spring Heart	65	70 Heart 3	110
27 Twin Hearts with Stand	98	<i>Back Cover</i>	
<i>Page 11</i>		Heart Module 4	22
28 Heart on Pyramid	81	Love on the Rock	52
29 Generations of Love	29	A Heart for Two	90
30 On a Stand	54	Heart Module 2	19
31 Broken Hearted	107	"O"-Hearted	114
32 Flip over Heart	35		
33 3-D Heart (Corrie's)	108		

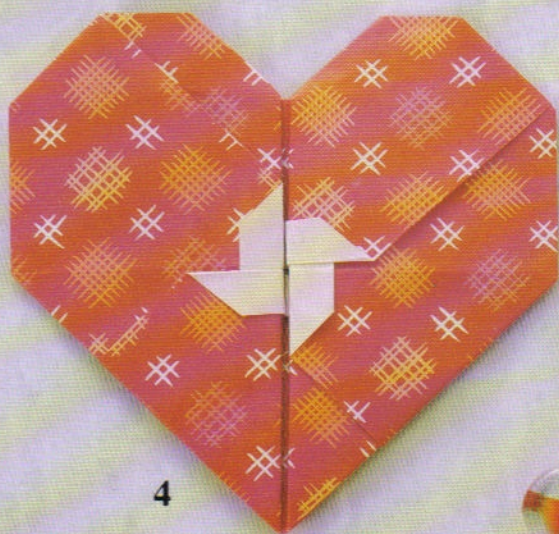
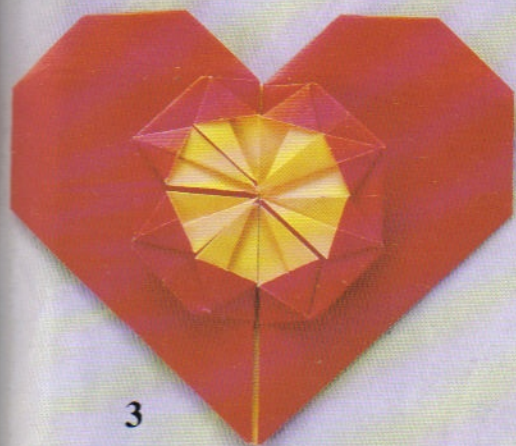
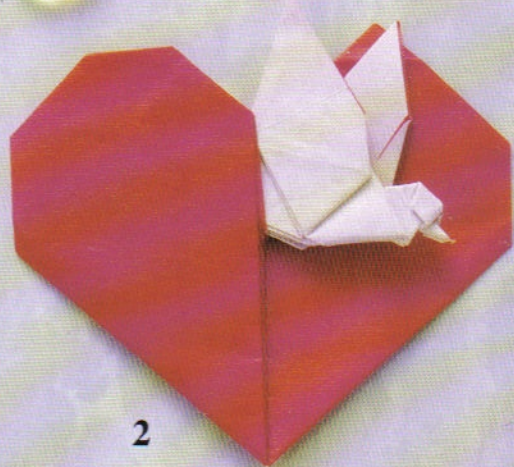

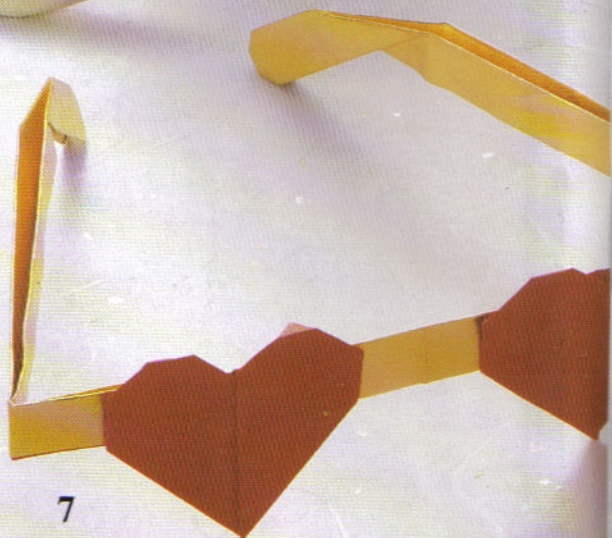
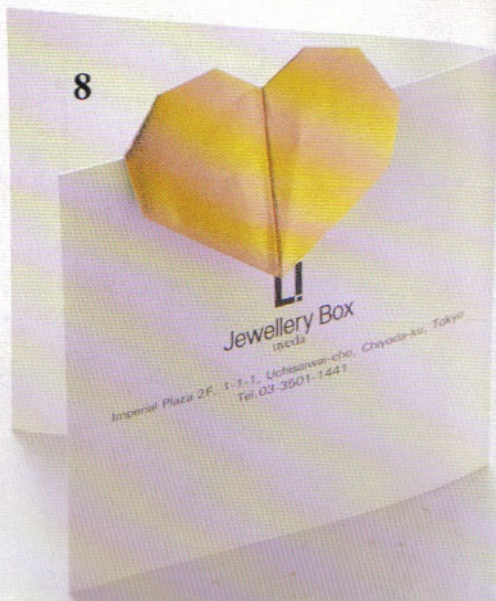
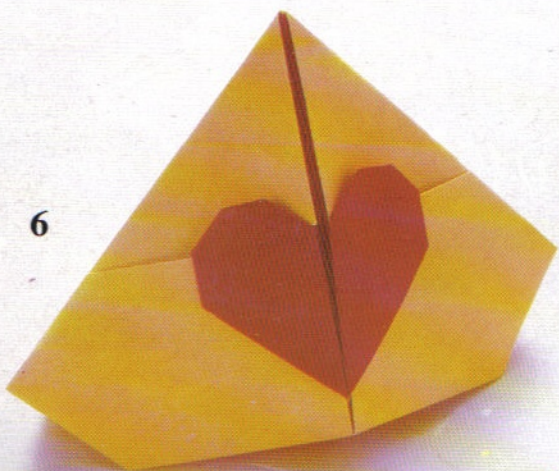



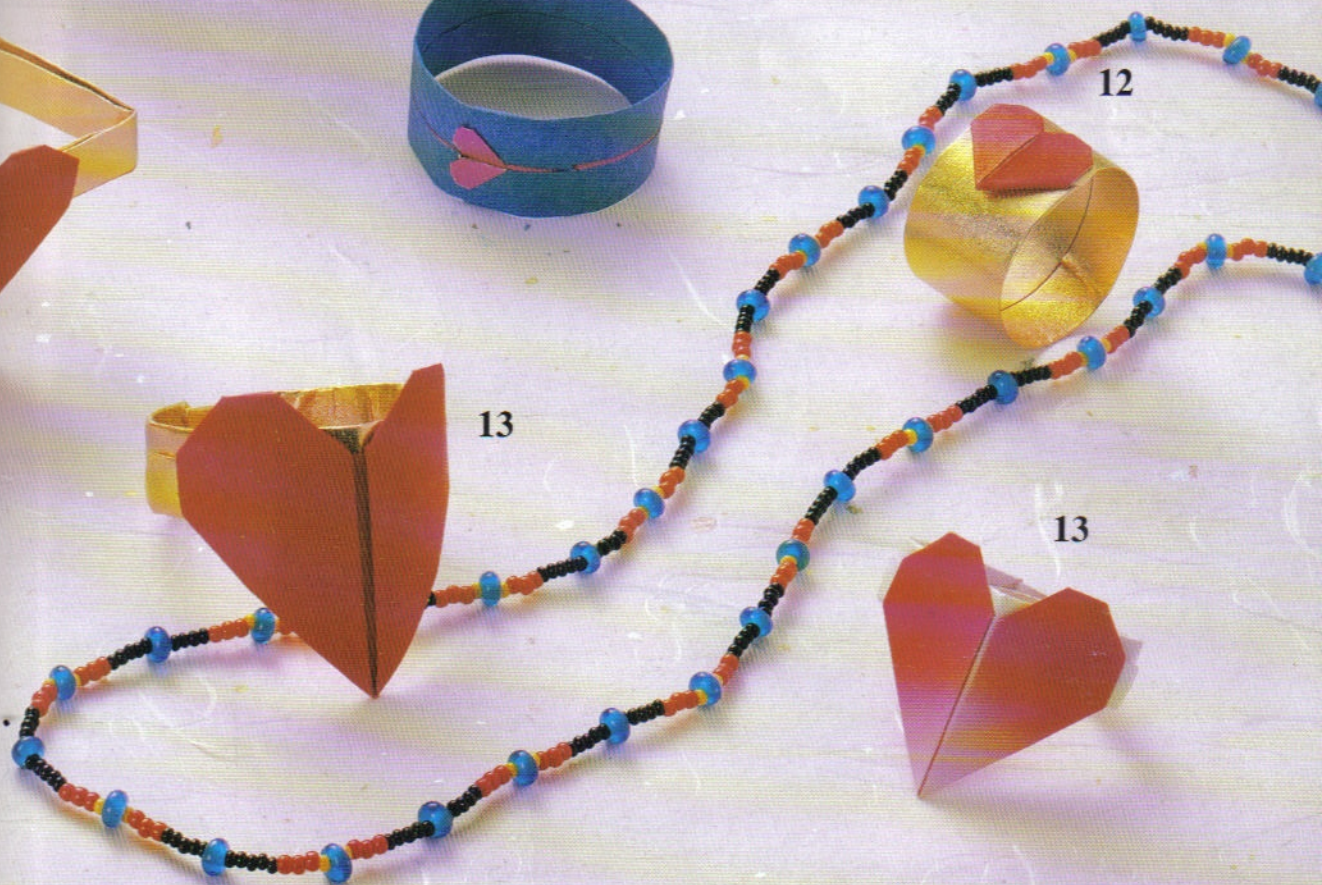
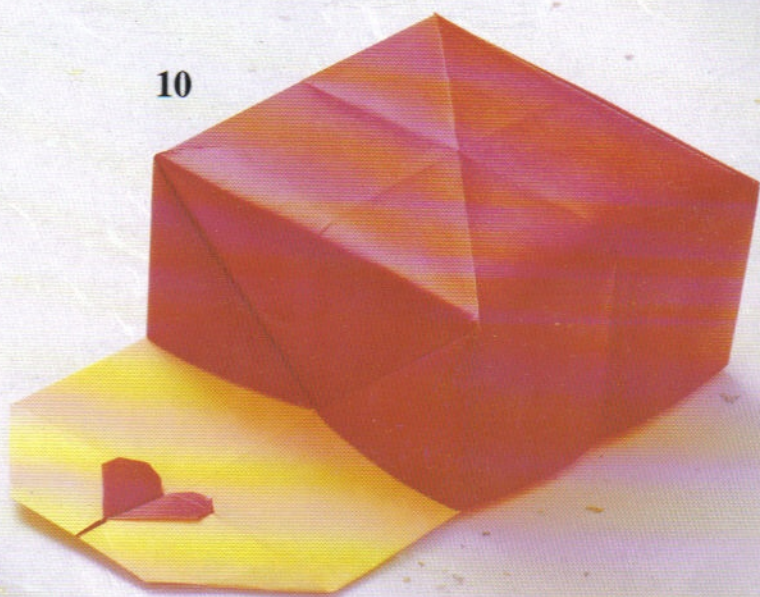
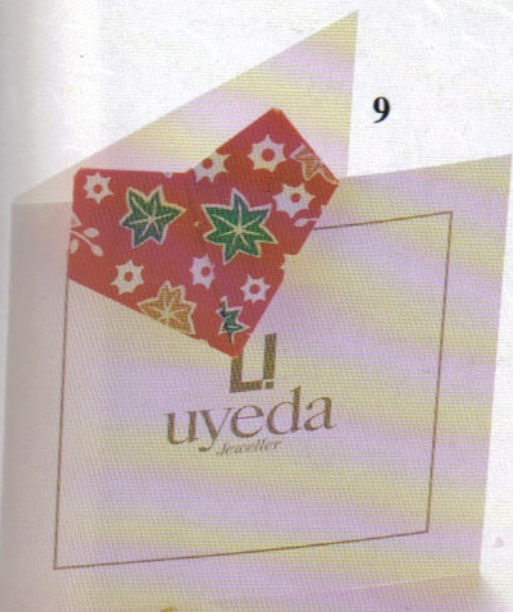

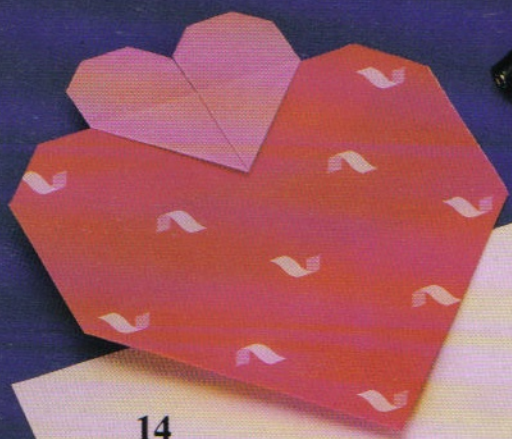

14



15

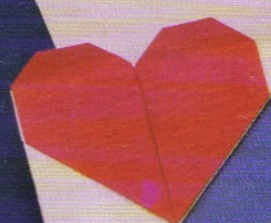

16

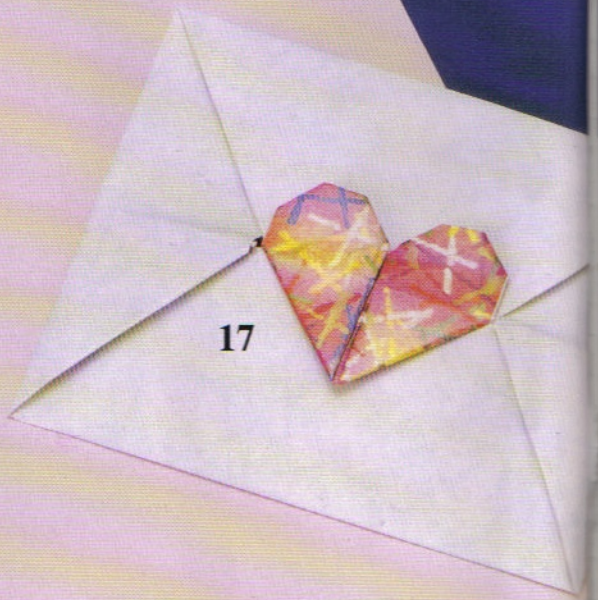
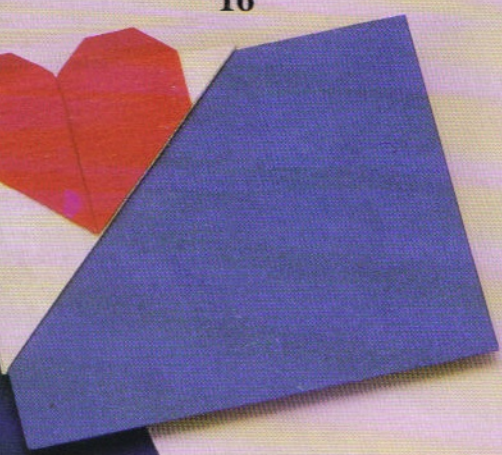

17

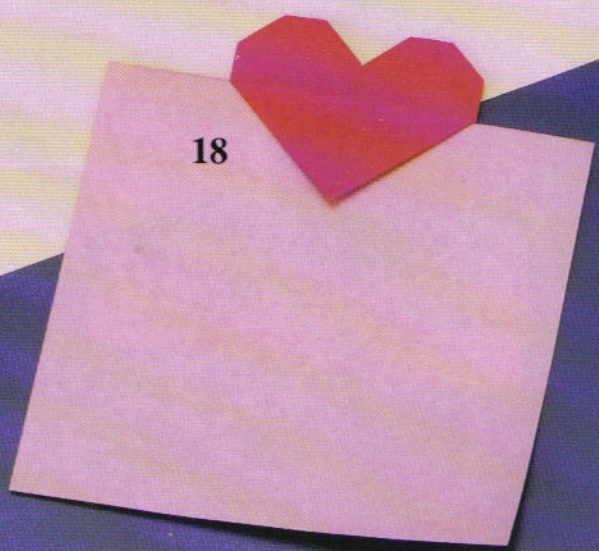

18



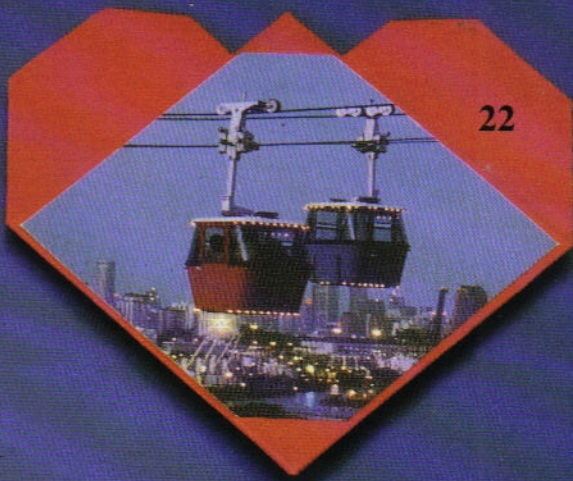
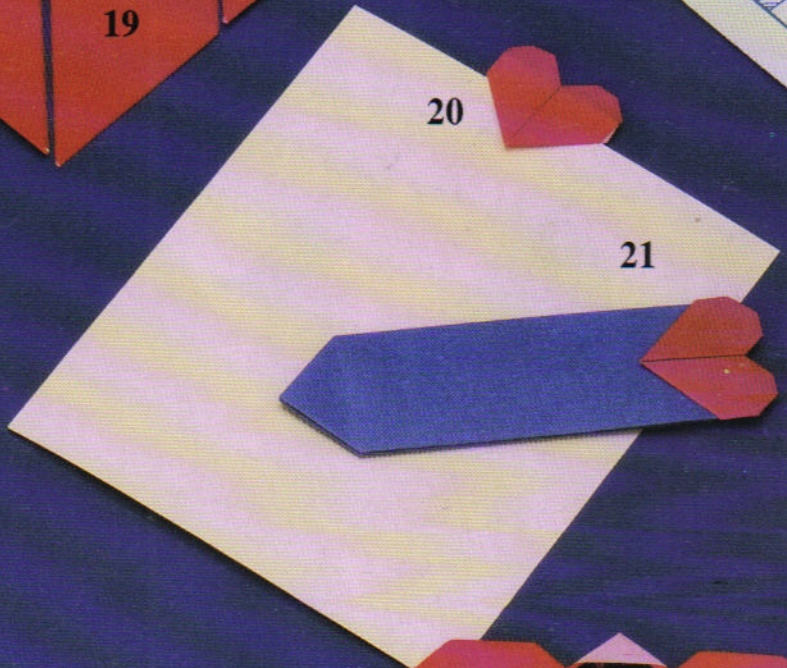
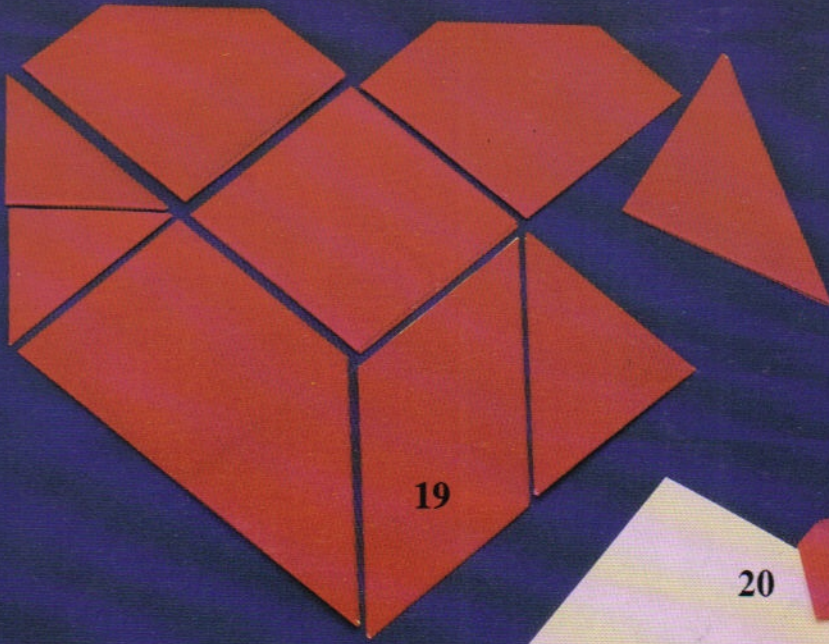

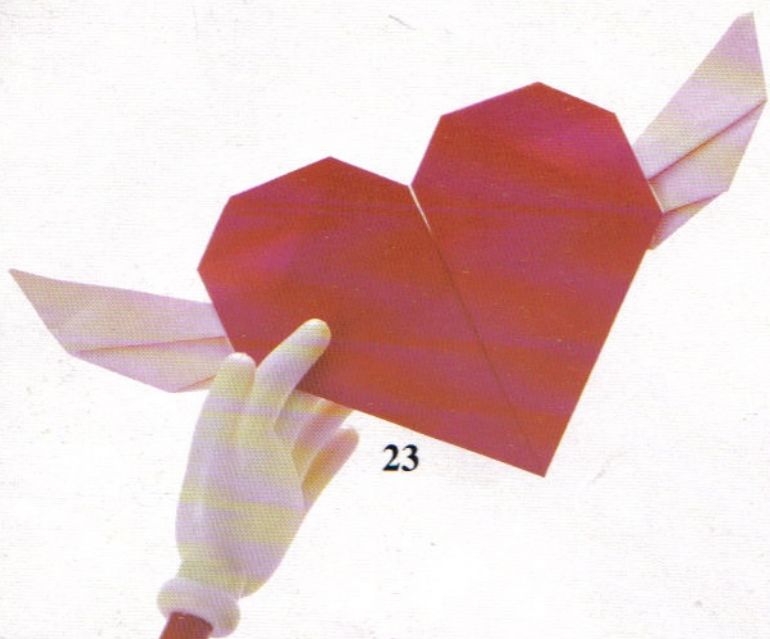

23

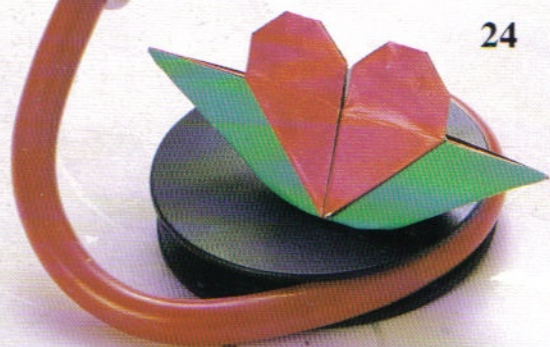

24

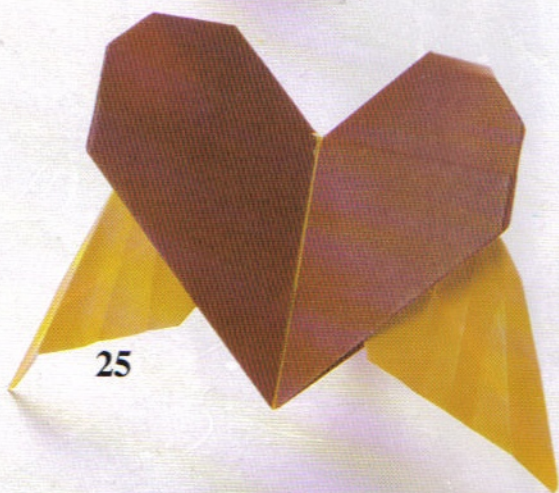

25

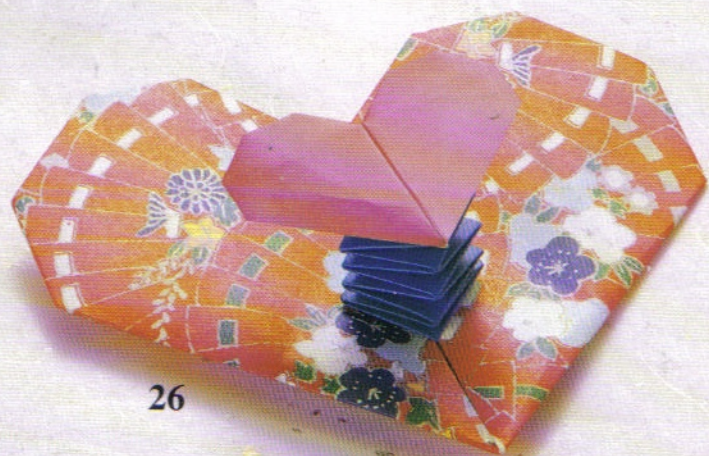

26

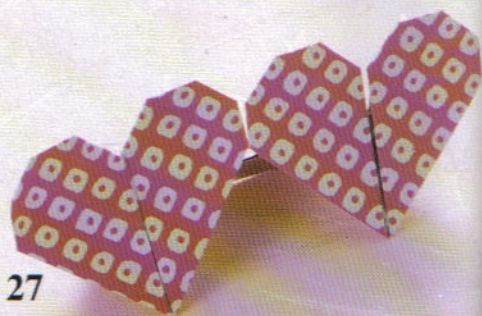

27



28

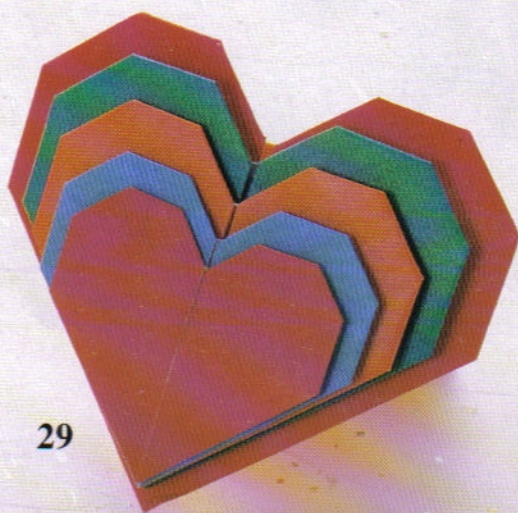

29



30



31

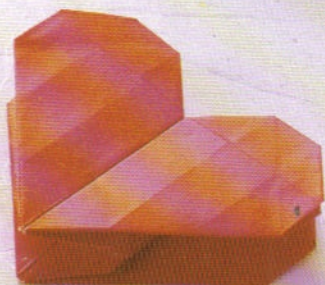

32



33



34



35

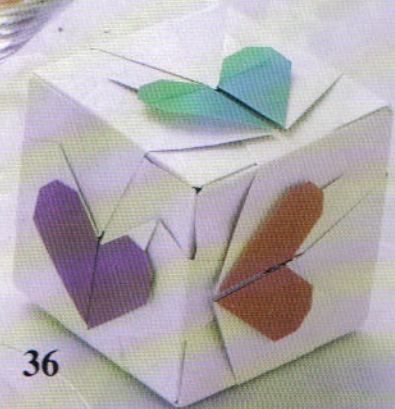

36



38



37



39

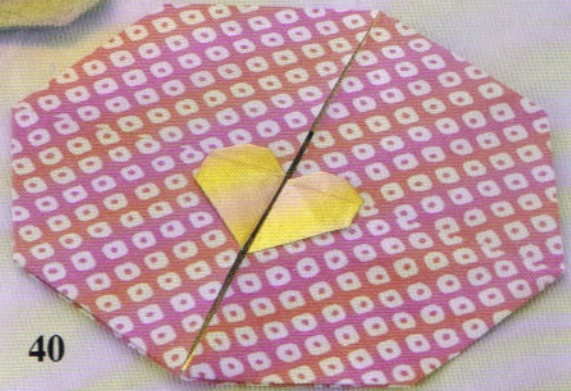

40

# Contents

---

Acknowledgments	3
List of Illustrations	4
Introduction	15
Symbols and Folding Techniques	16
Heart Module 1	17
Heart Module 2	19
Heart Module 3	20
Heart Module 4	22
Heart Module 5	25
Heart Cube Module	28
Generations of Love	29
Heart Frame	31
Love Triangle	33
Flip-Over Heart	35
Photo Frame with Hearts	38
A Gift of Love	40
Heart Ring 1	41
Heart Ring 2	42
Bigamous	43
Heart on Heart	44
Lover's Hat	44
Love Cap	45
Half-Hearted	46
Pockets for Half-Hearted	47
A Better Half	48
Coaster	49
Dutch Valentine Card	50
Box	51
Love on the Rock	52
Falling in Love	54
On a Stand	54
2's Company, 3's a Crowd	55
4's Too Many, 8's an Orgy	56
Heart Envelope	57
Sweet Heart	59
Love Boxes	60

Flowery Heart	62
Heart [Fuse's Lock]	64
Spring Heart	65
Windmill on Heart	67
Baby Love	69
Puppy Love	71
Loving Pajaritas	73
Heart Tatou	76
Heart Pin	78
Double-sided Heart	80
Heart on Pyramid	81
Heart Module 6	82
3-D Heart (Petty's)	83
Head Over Heels	84
Heart Brooch (Accroche Coeur)	86
Winged Heart (Coeur Ailé )	87
Flying Heart	89
A Heart for Two	90
Love Birds	91
Love Dove	92
Circle of Hearts (Modular)	94
Heart Ring 3 and Book Marker	95
Heart Corner Marker	96
Heart Corner Maker 2	97
Twin Hearts with Stand	98
Changing Heart	100
Heart Tangram	101
Love is Blind	104
Broken Hearted	107
3-D Heart (Corrie's)	108
Heart 2	109
Heart 3	110
House of Love	111
"O"-Hearted	114
Heart 4	117
2-Piece Heart Coaster	118



## *Introduction*

This book is dedicated to matters of the heart and presented here are some ways in which this can be expressed through ORIGAMI, the Japanese Art of paper folding. I hope you may gain something from these pages, that the models presented here may be useful for you to convey your feelings to the one(s) you love and perhaps inspire you to create your own models.

You can start folding from any part of this book as the models are not arranged in order of progressive complexity. However, certain models with the same starting bases are grouped together. In such cases, when you have difficulties in folding, simply refer to the models which appeared earlier.

Included in this book are also some modular folds. For these, you need to make the number of units required and then assemble them together. Cutting and the use of glue is not necessary and the only requirement is precision. Pay careful attention to the creases and location points and always look one step ahead. The diagram of each step is the result of folding of the previous.















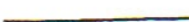
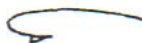



Any type of paper can be used to fold most of the models presented here but for certain models, paper-backed foil is necessary. You can also use any color but red colored paper is most suitable for heart models. For models which show both sides of paper, "Duo-colored" paper is preferred. I use standard Origami paper (150mm × 150mm or 6" × 6") for models which begin with squares. For models folded from rectangles, the proportions are cut from the standard square.

Use larger papers for practicing and when you are familiar with the folding procedures, fold it from a smaller paper. A smaller model not only looks more attractive than a larger one, it can also be easily contained in an envelope together with your love letters, cards or gifts. This will provide the recipient with a little something which is not easily available. Something meaningful, something origami coming straight from the heart.

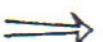
As intended, most of the models here carry a hidden message, usually a message of love. Some models are meant for just one purpose, some more than one. Some even for the purpose of insulting. For whatever purpose these are being used for, I hope you enjoy folding the models in this book. When you have folded all the models here, you will discover that like love, Origami is a many splendored thing.

Francis M. Y. Ow.

# Symbols and Folding Techniques

	Vally line		Insert
	Mountain line		Fold to the front
	Edge of paper		Fold behind
	Crease line		Fold and unfold to crease
	Imaginary line or X-ray view		Fold and fold
	Push in or sink		Pleat or crimp
	Enlargement		Turn over
	Reduction		Turn to rotate
	Stretch or pull		Location points
	Repeat		Equal lengths

## Division of 3rds

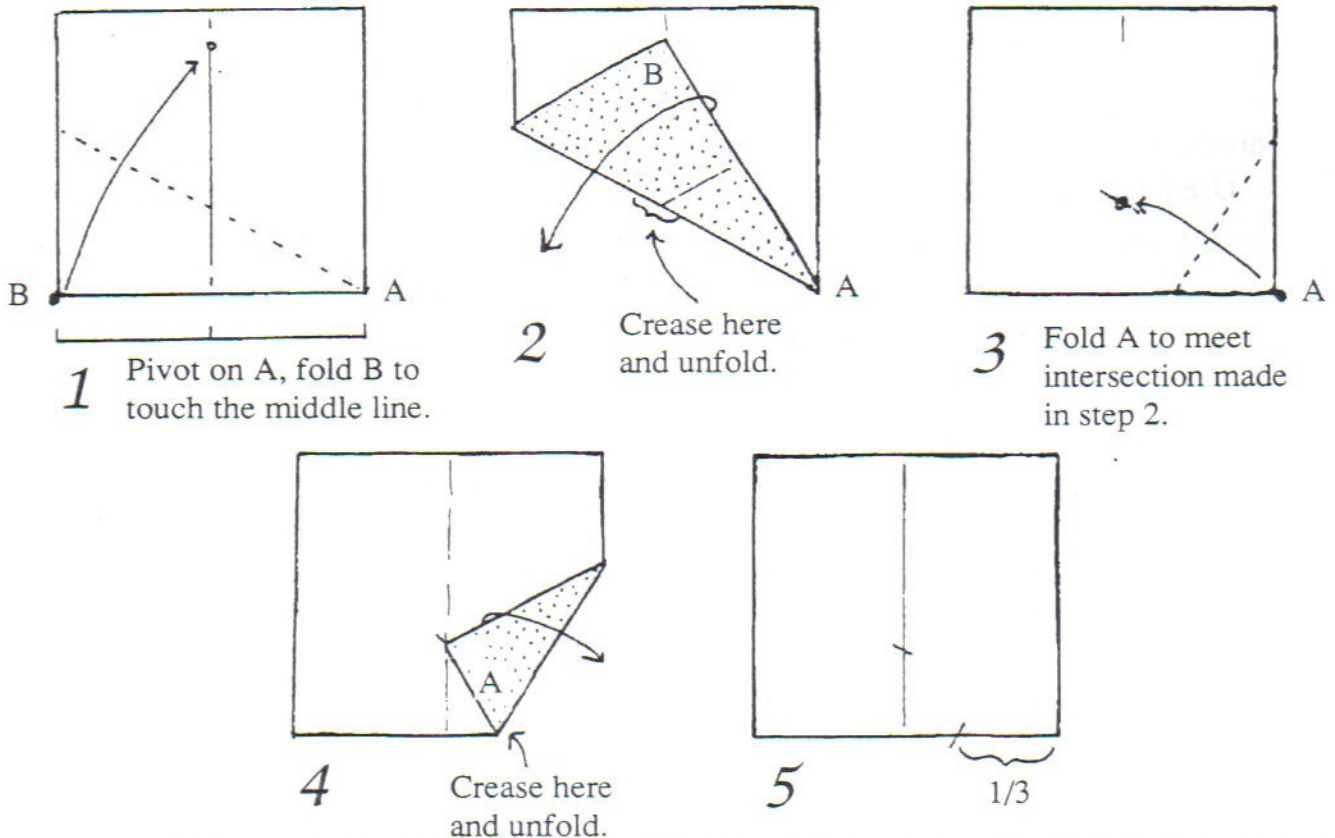

# Heart Module 1



1 3 × 1 rectangle.  
Color side up.

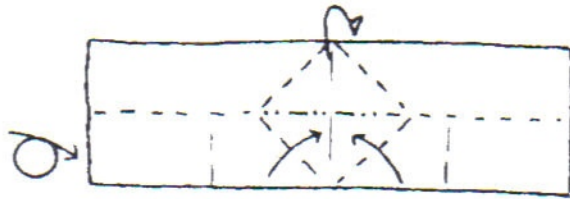

2

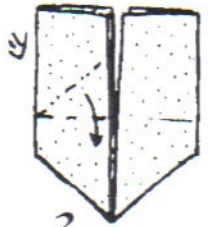

3

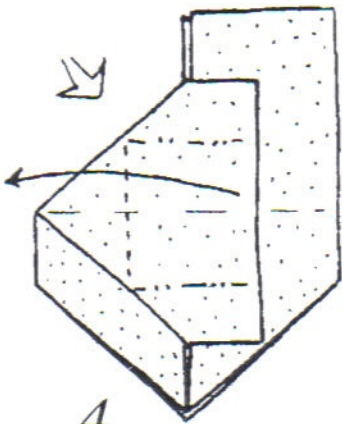

4

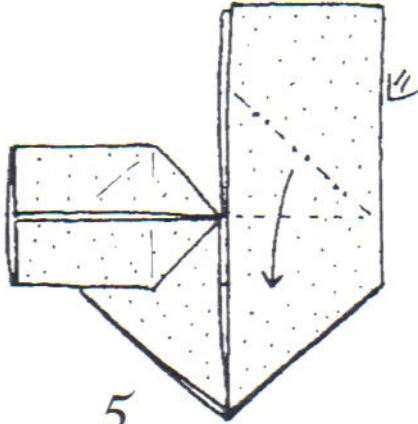

5

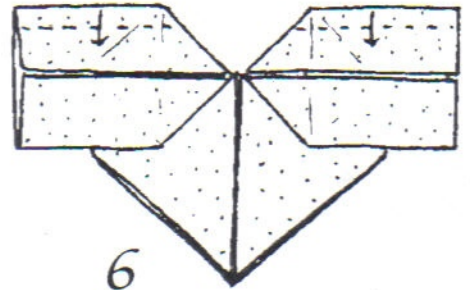

6

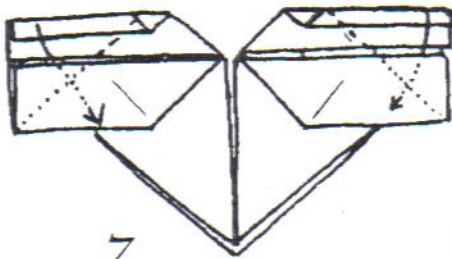

7

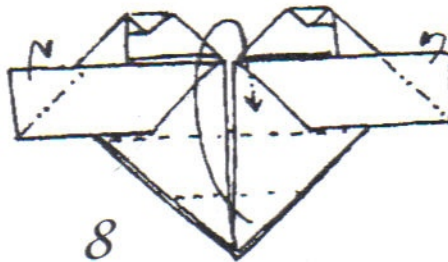

8

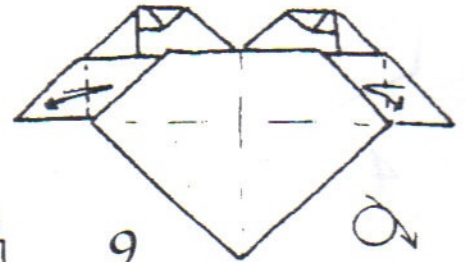

9

## Assembly

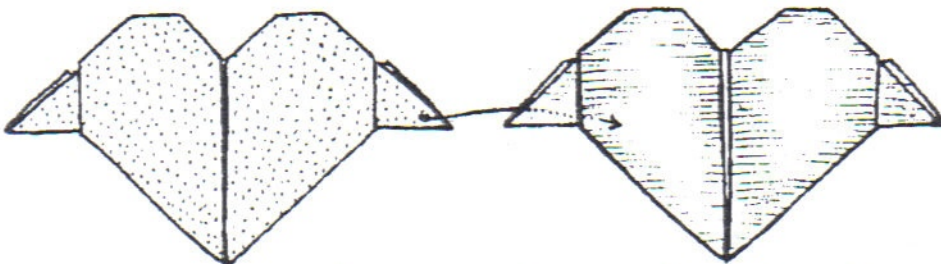

Connect more hearts to form a ring of hearts.

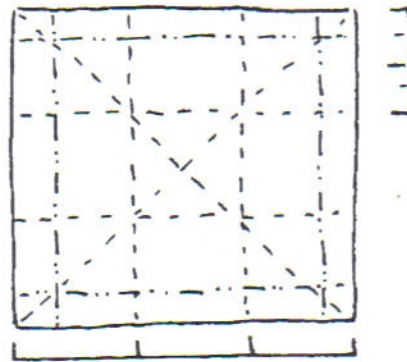
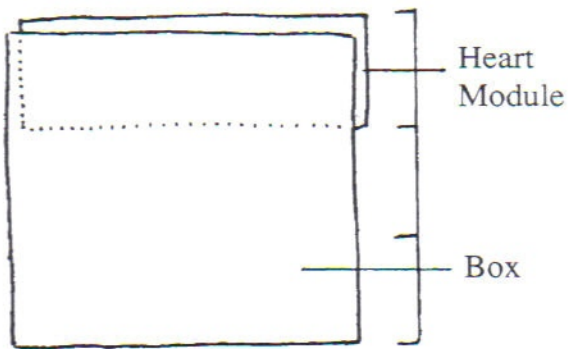

1 Pre-crease and form box.

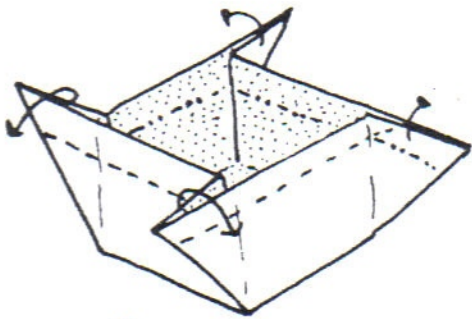

2

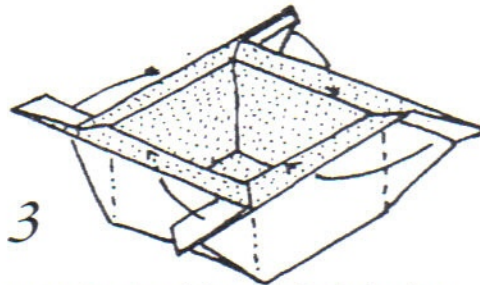

3

Tuck in the sides while bringing the top edges down.

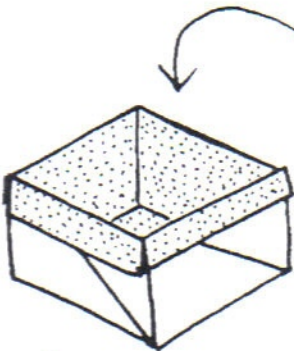

4

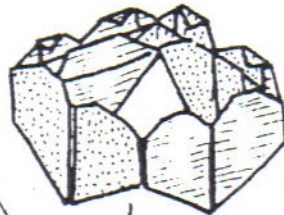

Form a ring of 4 hearts from MODULE 1 and fit it around the box.

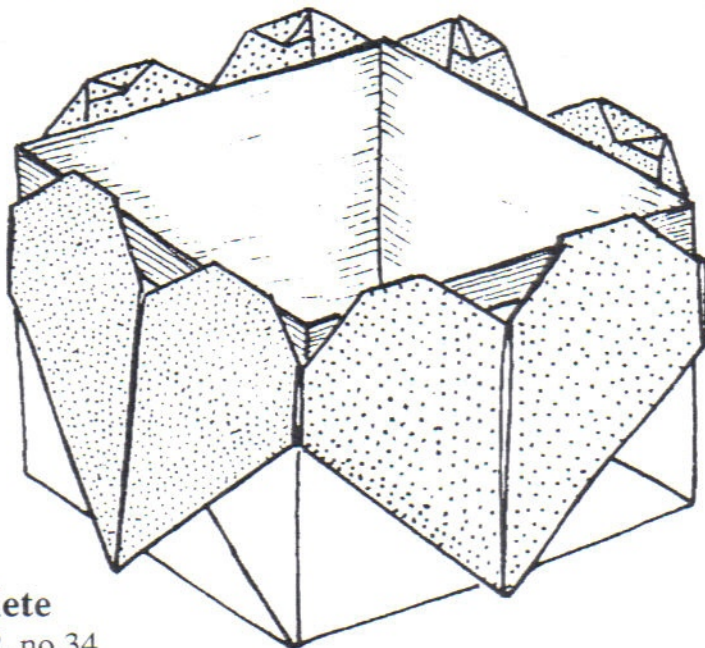

5

**Complete**  
See p.12, no.34

# Heart Module 2

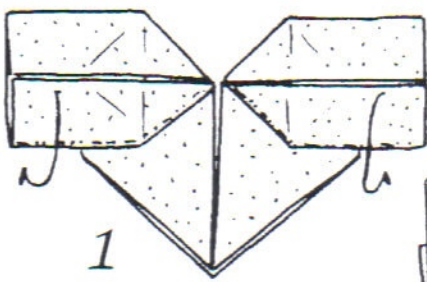

1

Step 6 of MODULE 1.  
Color change.

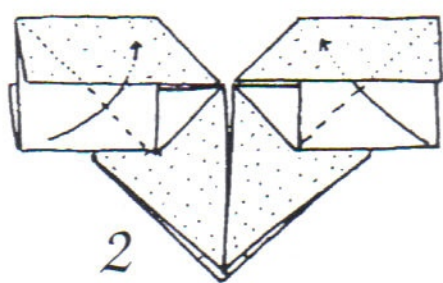

2

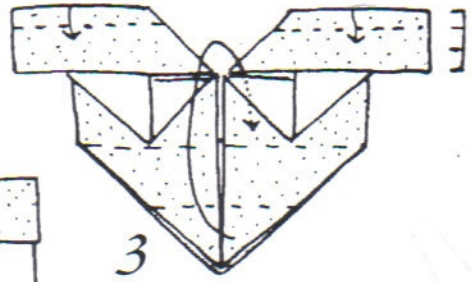

3

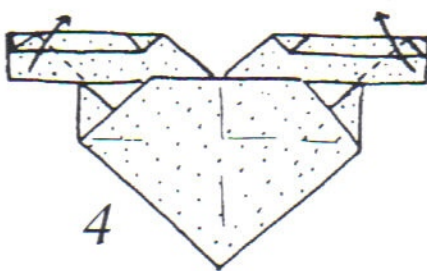

4

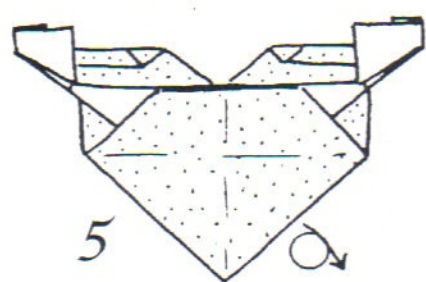

5

**Assembly**

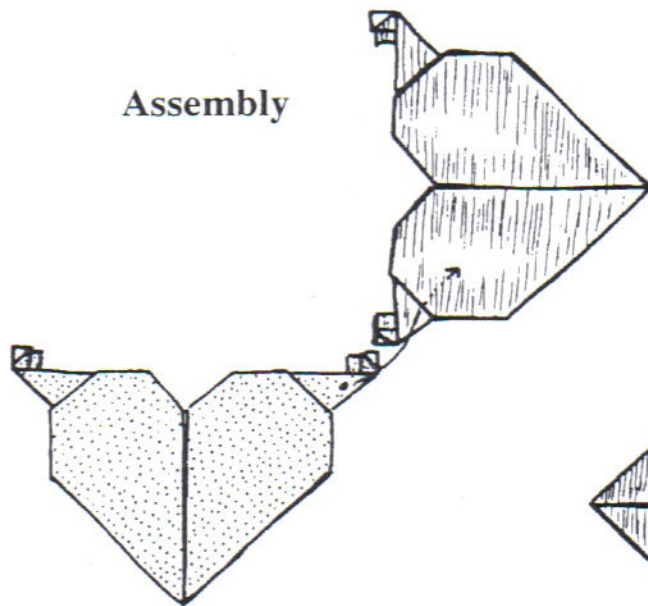

Connect 4 modules  
to form a coaster.

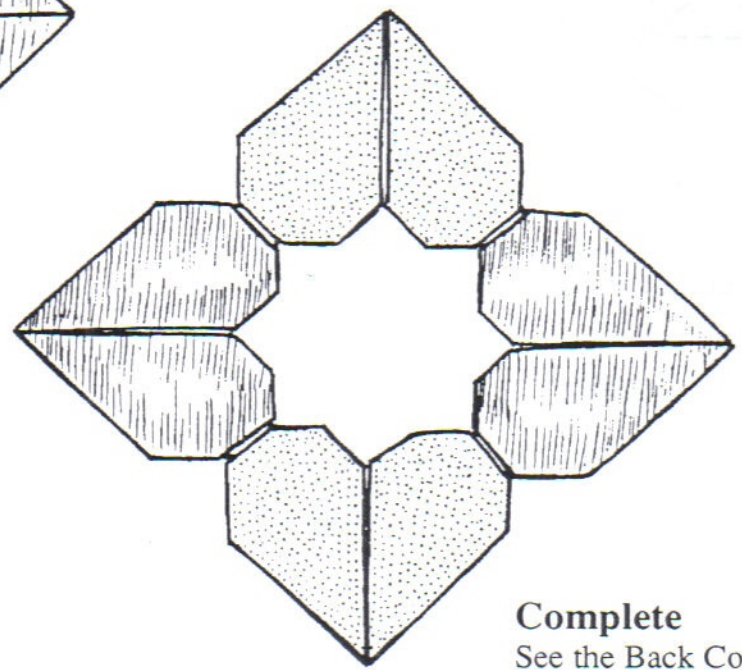

**Complete**  
See the Back Cover.

# Heart Module 3

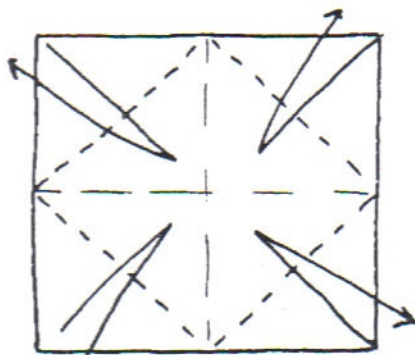

1 White side up.

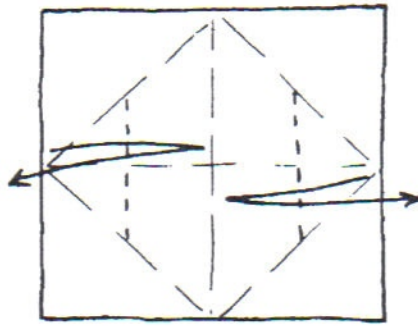

2 Pre-crease on steps 1 to 5.  
Note location points.  
Do not crease beyond.

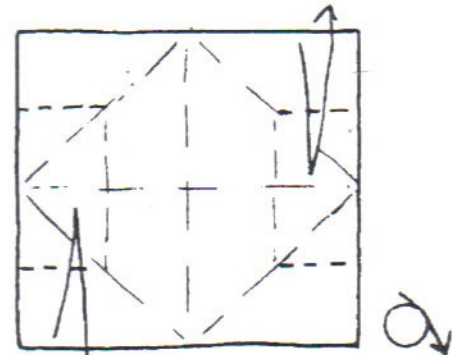

3

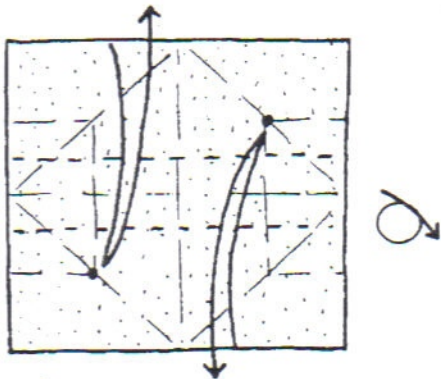

4

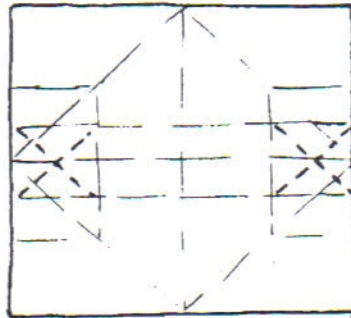

5

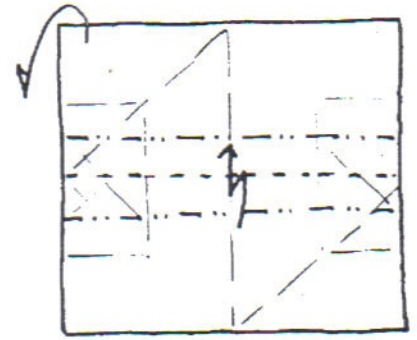

6

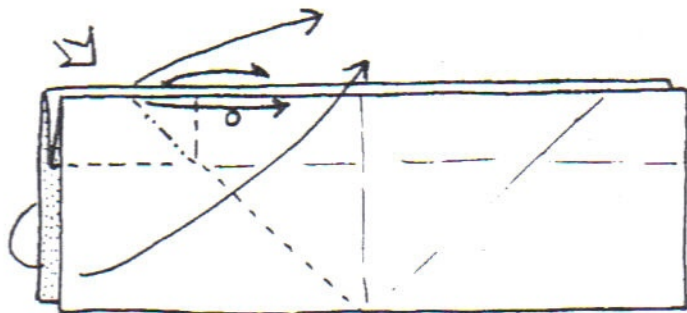

7 Hold point o, spread out the pleats and bring the bottom left edges to the center line.

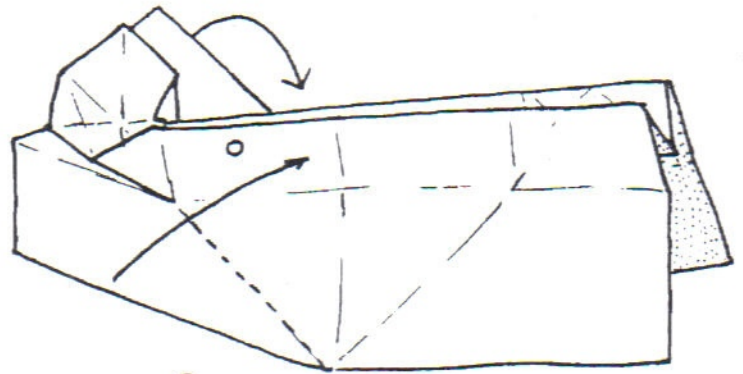

8

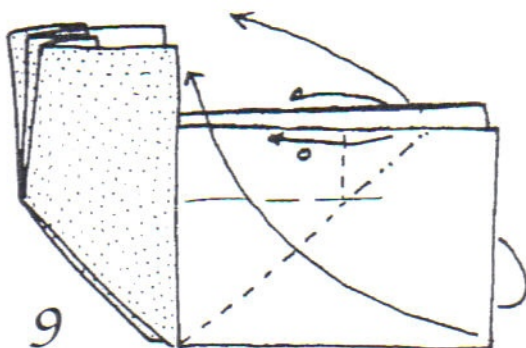

9

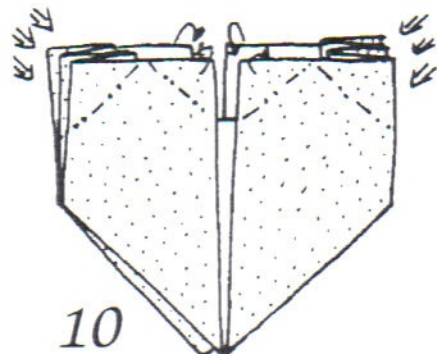

10

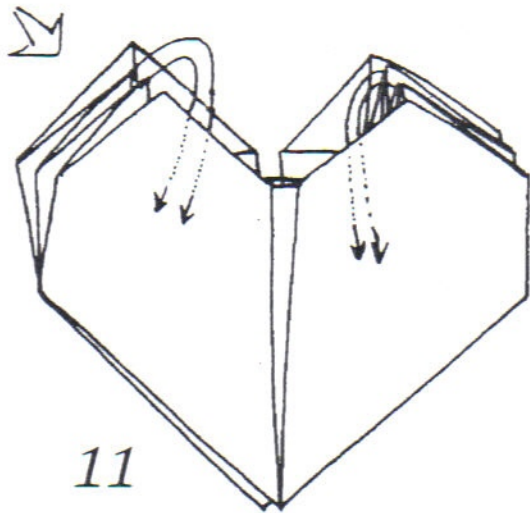

11

Fold the 4 inner points into the middle pleat.

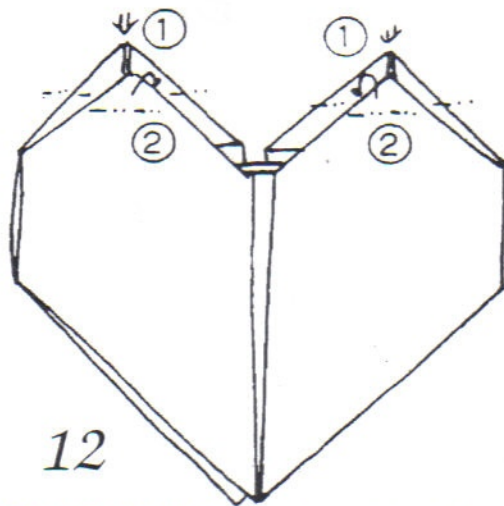

12

Sink the bottom points and tuck the front points in. (Refer to steps 19 to 20 of FLIP OVER HEART) (Shown on page 37)

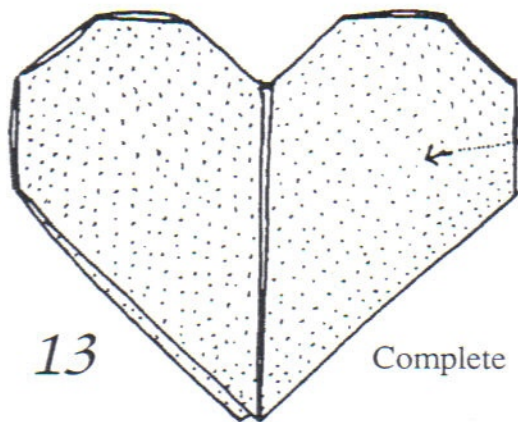

13

Complete

Page or index marker

See p.9, no.20

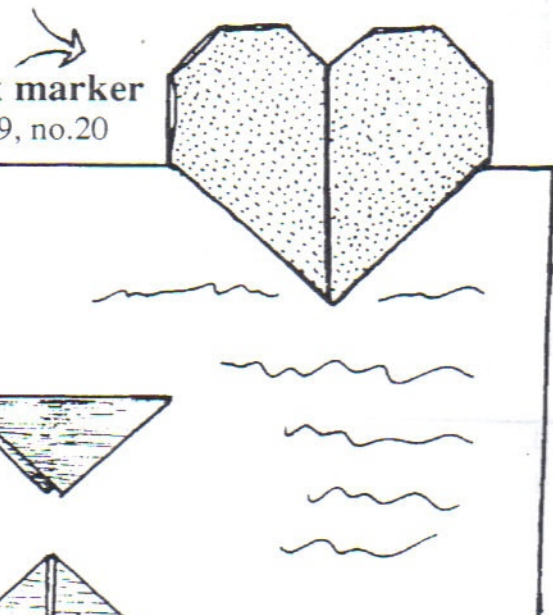

Connectors

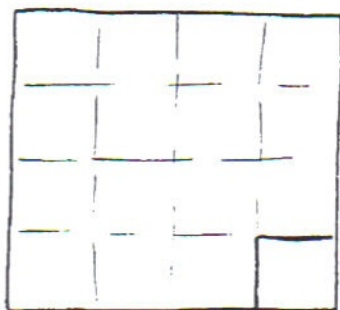

1

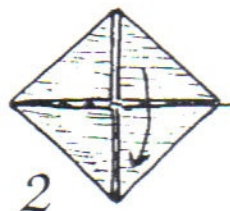

2



3

Connect more HEARTS to your heart's content.

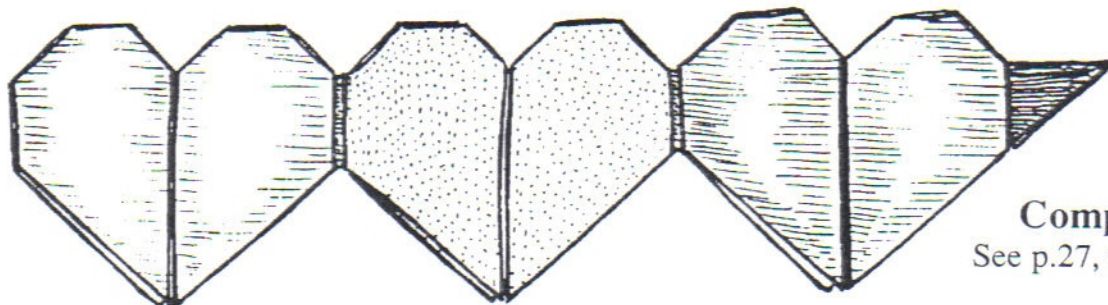

Complete

See p.27, no.41

# Heart Module 4

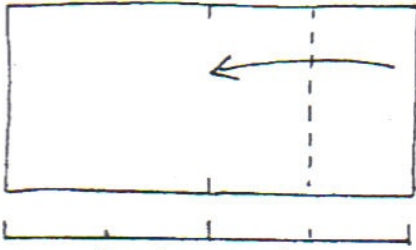

1 2 × 1 rectangle.  
White side up.

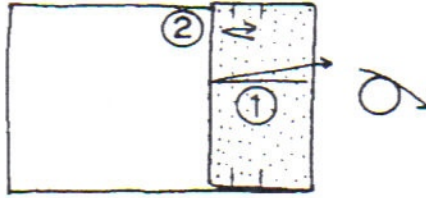

2 Crease only  
on the edges.

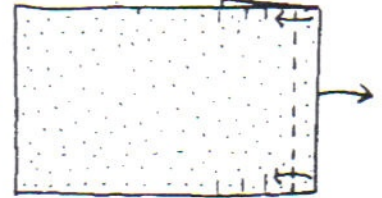

3 Note location  
points.

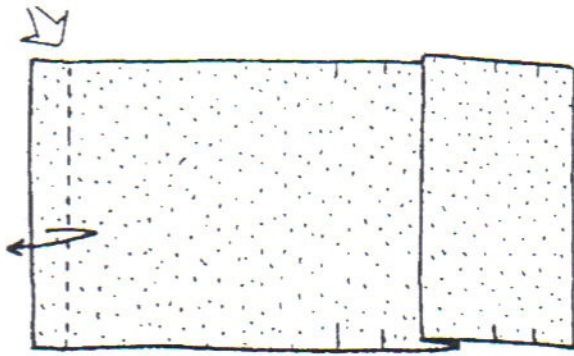

4 Note location points  
for steps 4 to 9.

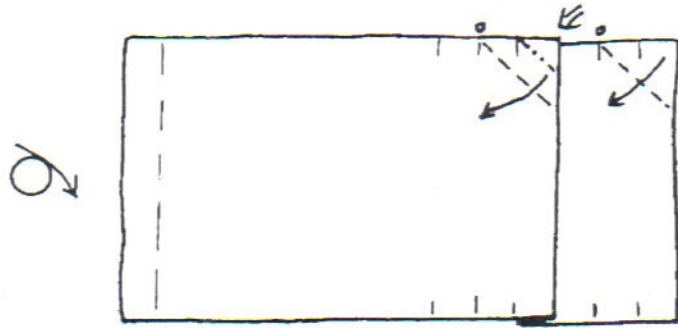

5

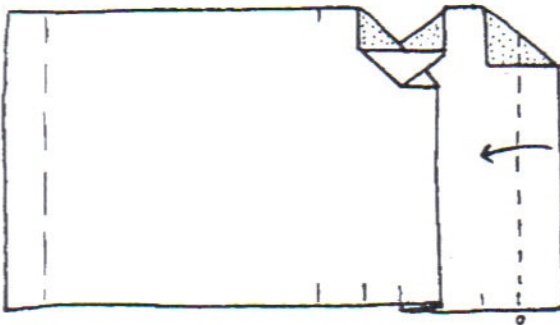

6

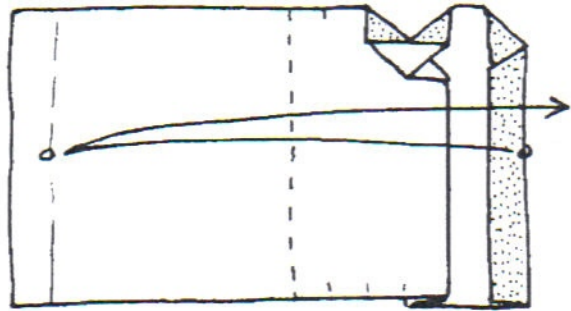

7

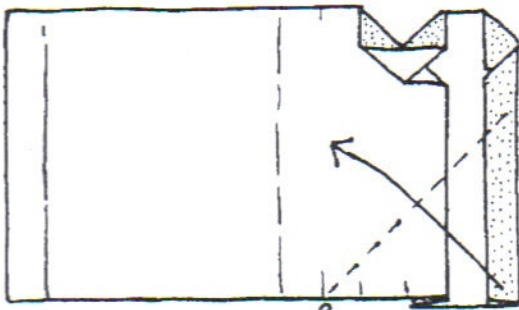

8

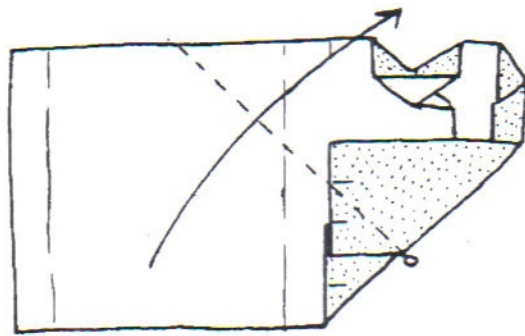

9



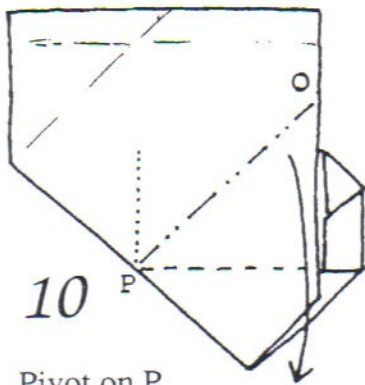

10

Pivot on P  
fold o down.

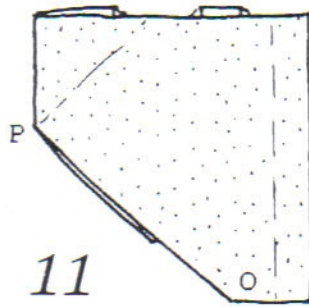

11

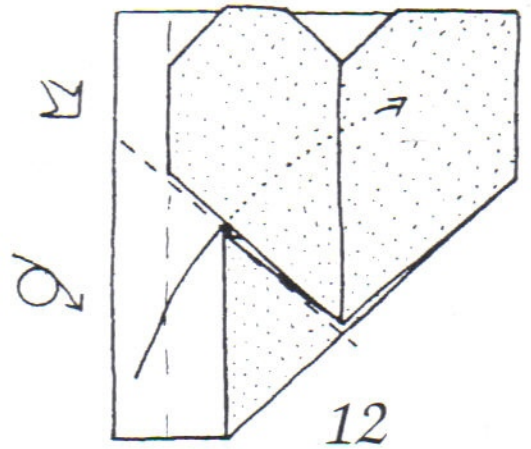

12

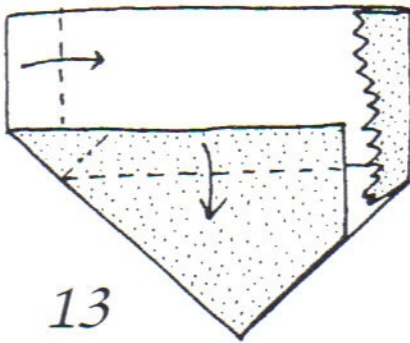

13

Top layer removed.

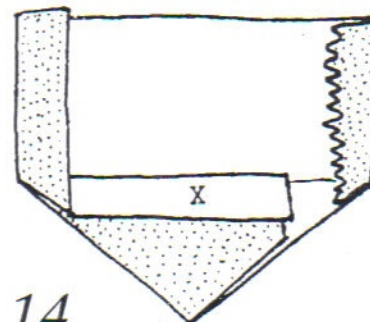

14

Tuck X into the slot  
behind the top layer.

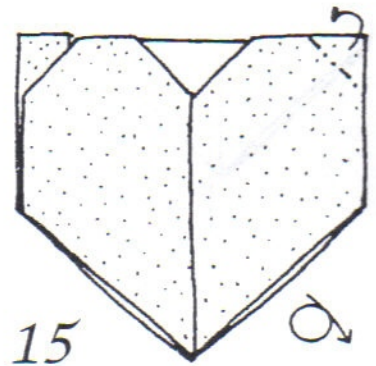

15

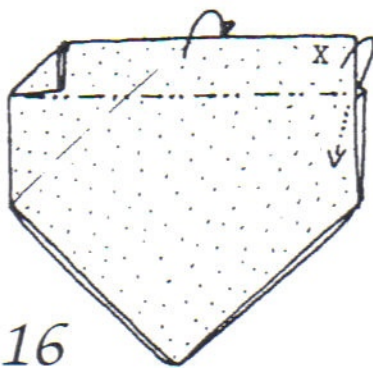

16

Mountain-fold and tuck  
X into the slot.

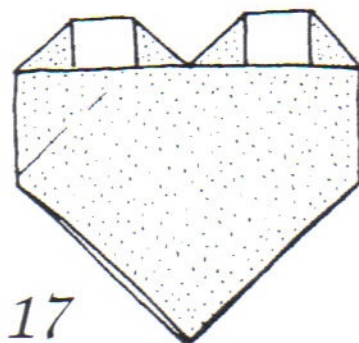

17

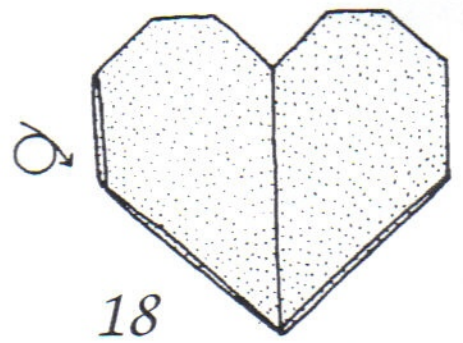

18

1 Unit complete.

### Connectors

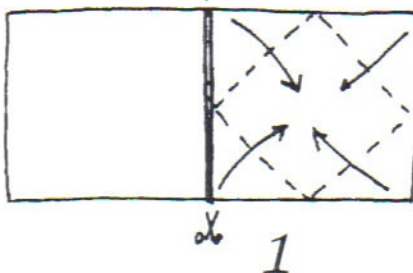

1

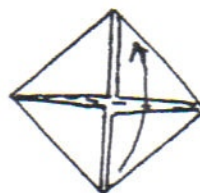

2



3

**Assembly**

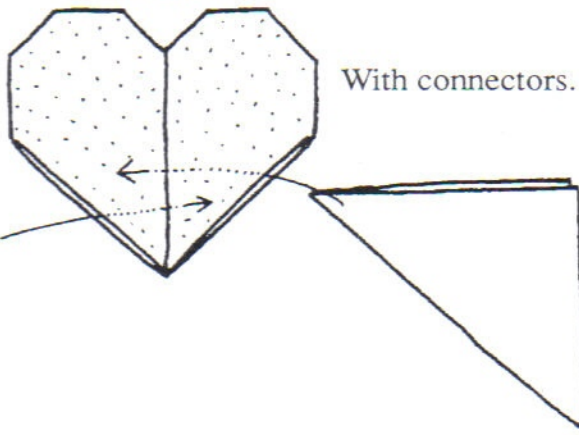

With connectors.

**Complete**

See p.27, no.44

× 4

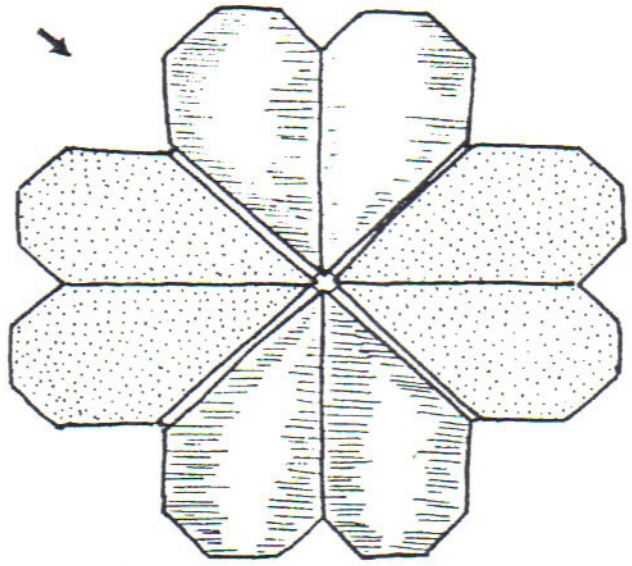

Without connectors.

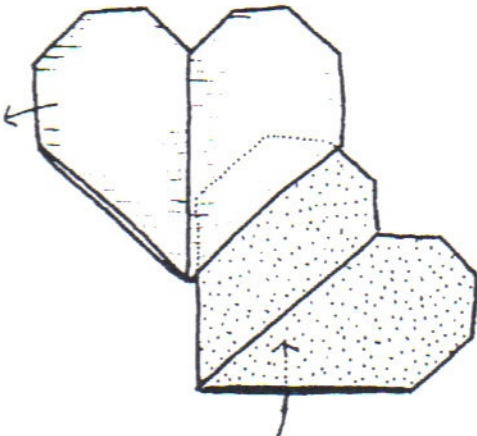

Insert next HEART here.

**Complete**

See the Back Cover.

× 8

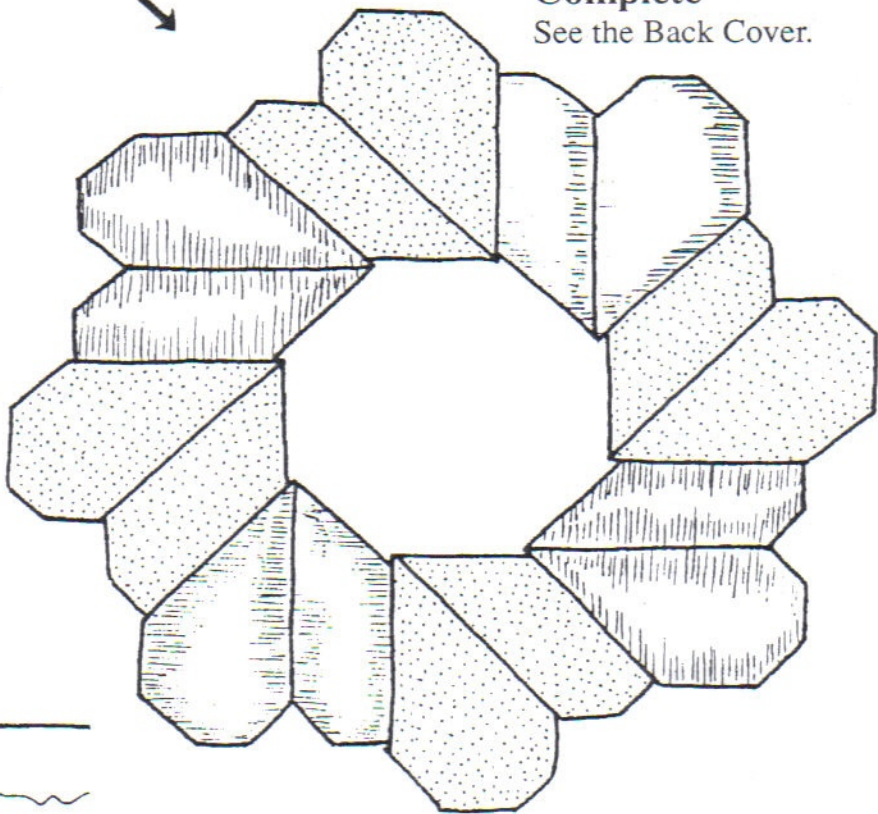

**PAGE MARKER**

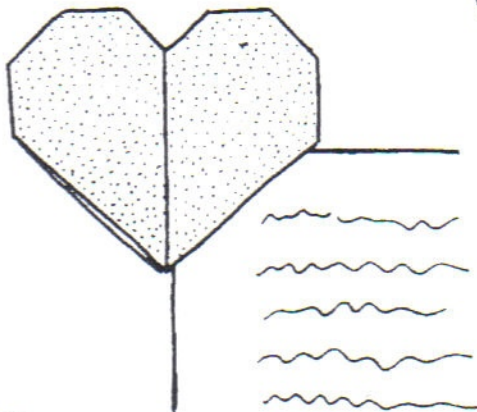

# Heart Module 5

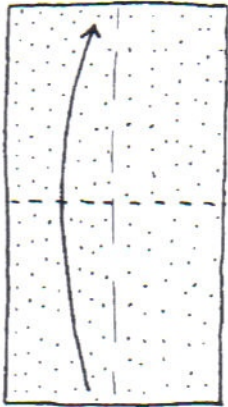

1 1 × 2 rectangle.  
Color side up.

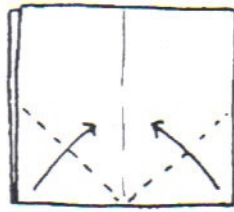

2

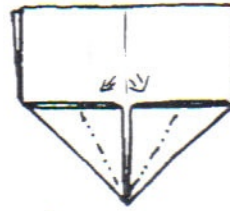

3 Squash.

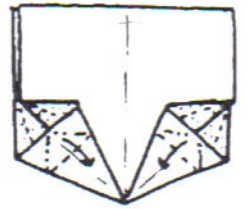

4 Petal-folds.

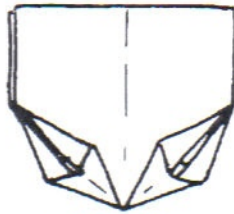

5 Unfold completely  
with WHITE SIDE UP.

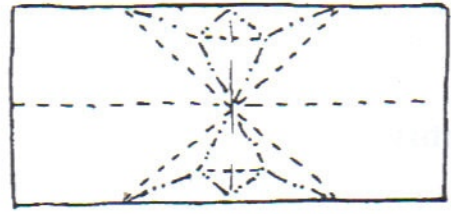

6 Refold with the  
Petal-folds inside.

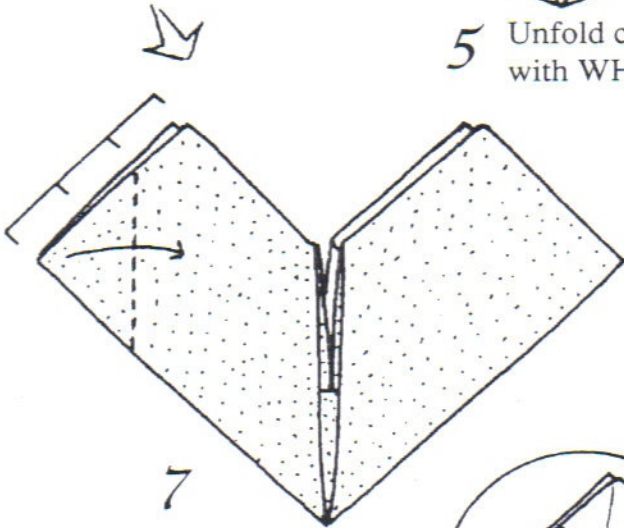

7

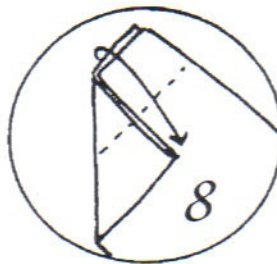

8



9

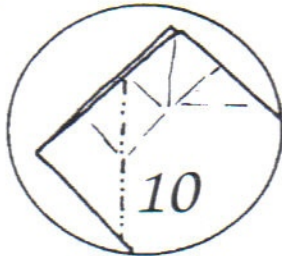

Reverse-fold.

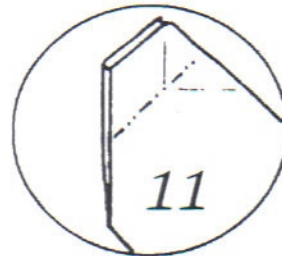

Reverse-fold  
the top layer.

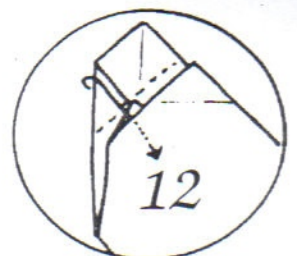

Insert.

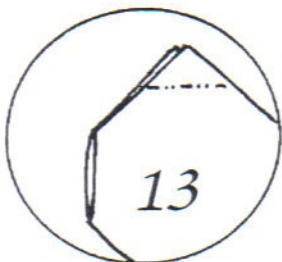

13

Reverse-fold  
the top layer.

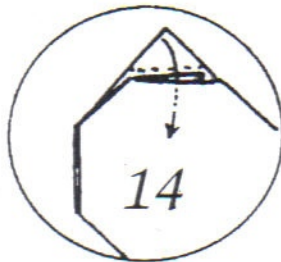

14

Insert.

Repeat steps 7 to 14  
for the right side.

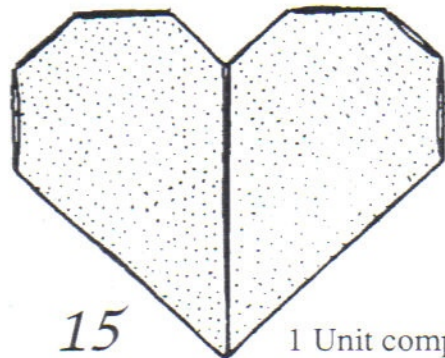

15

1 Unit complete.

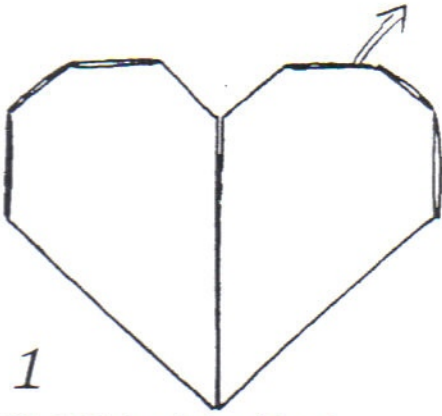

1

Unfold the right side of the heart to step 11.

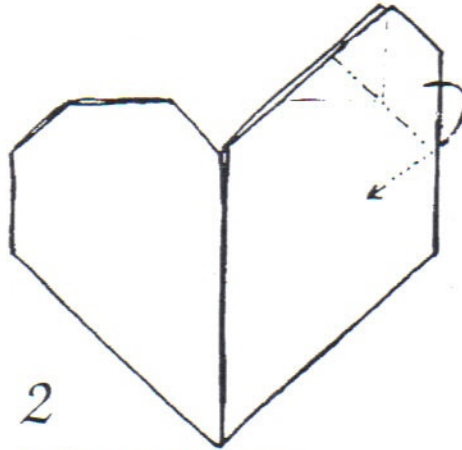

2

Refold as shown for the RIGHT SIDE ONLY.

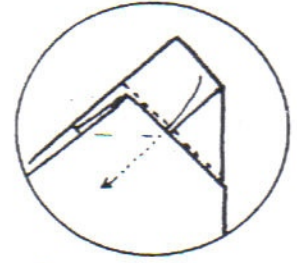

3

**Assembly**

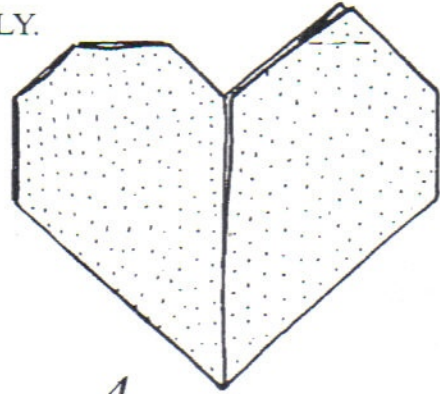
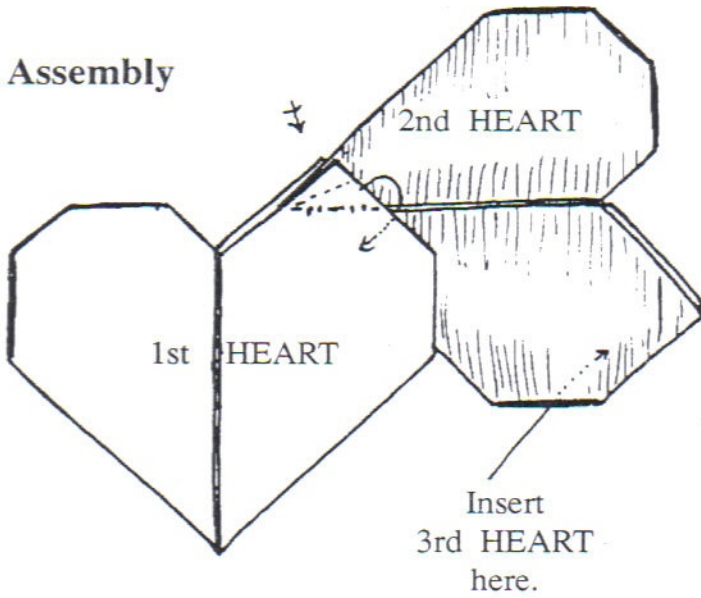

4

1 Unit Complete.

× 4

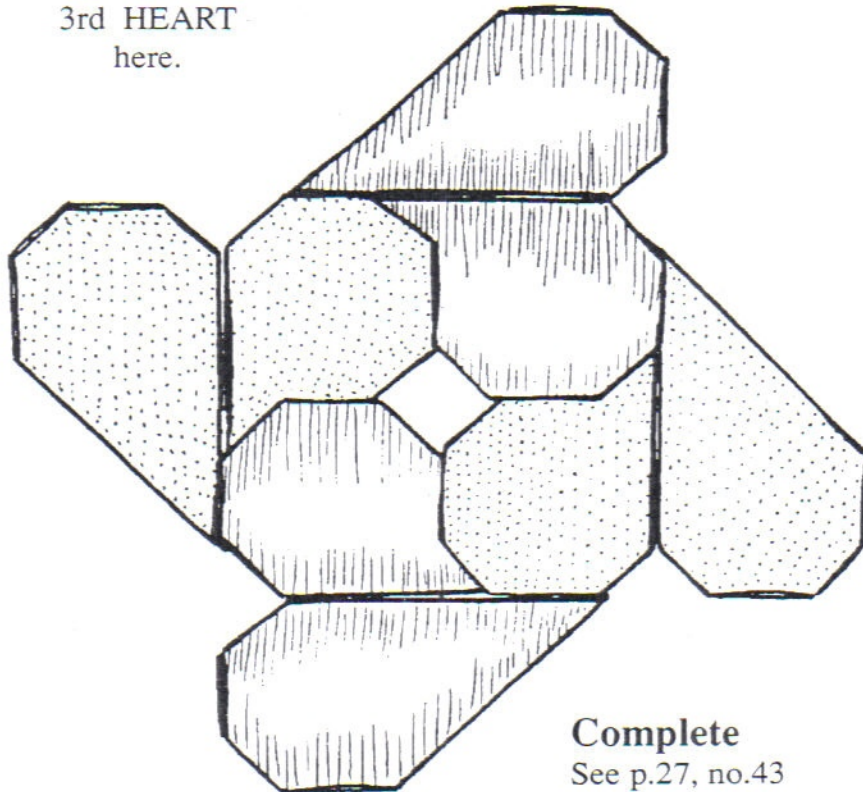

**Complete**  
See p.27, no.43

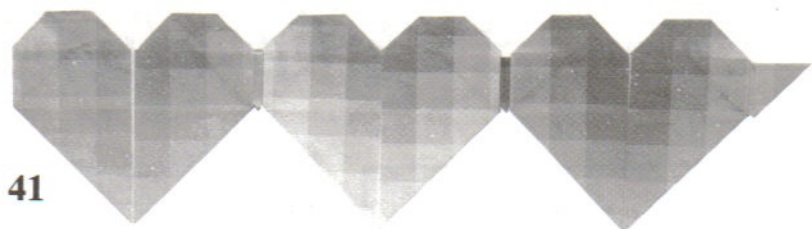

41



42

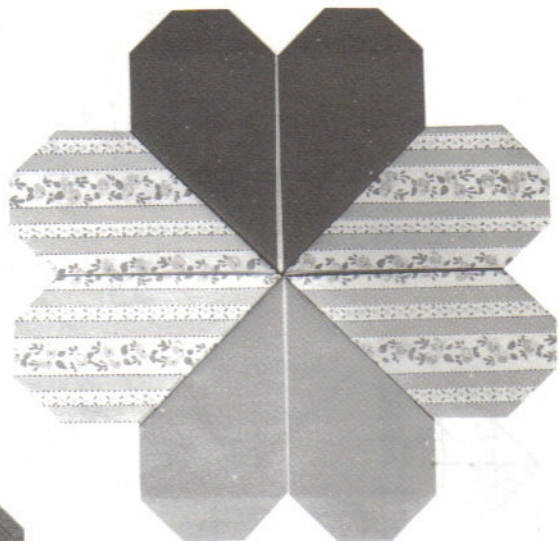

44

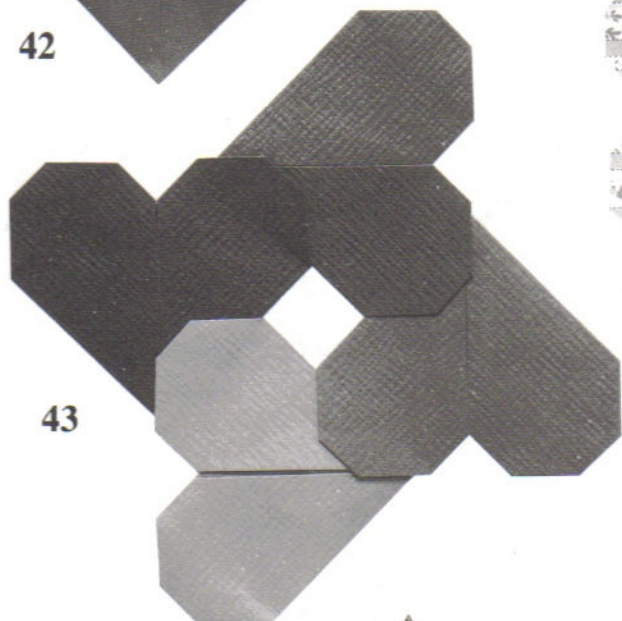

43



45



46

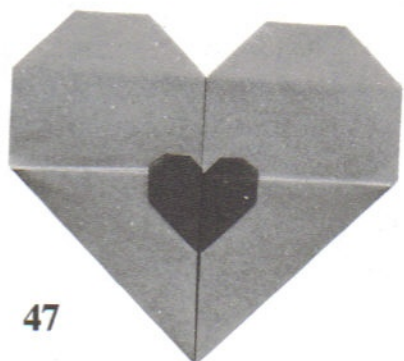

47



48

# Heart-Cube Module

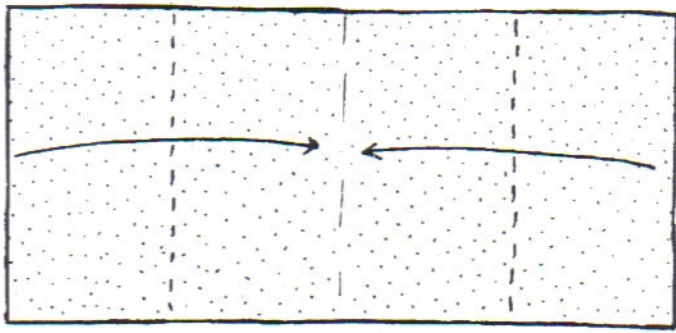

1  $2 \times 1$  rectangle.  
Color side up.

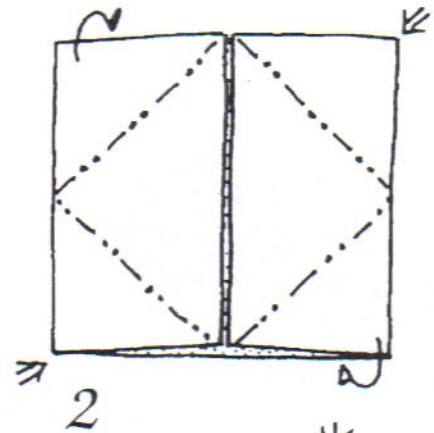

2

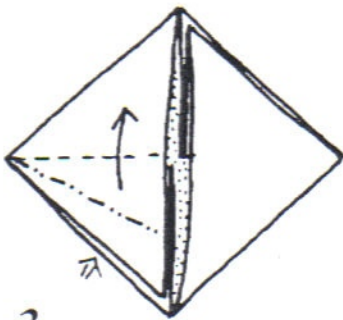

3

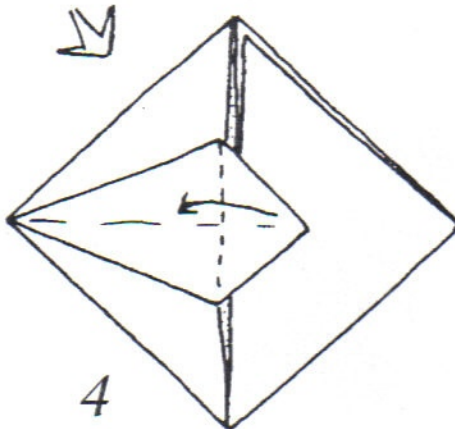

4

Repeat steps 3 and 4  
for the right flap.

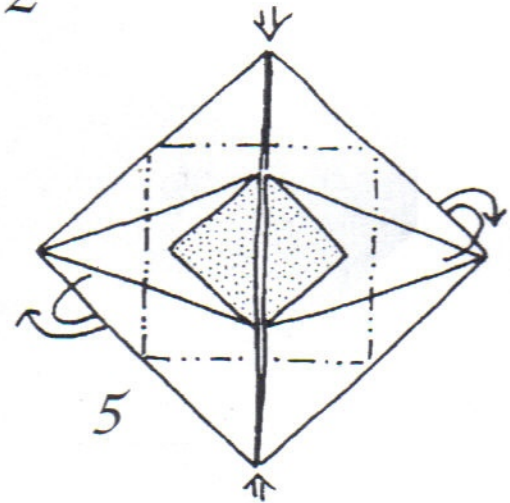

5

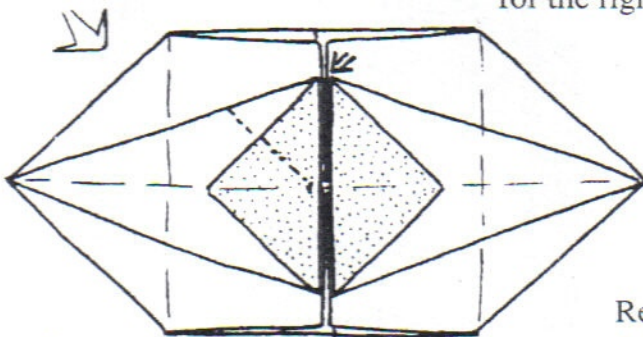

6

Reverse-fold.

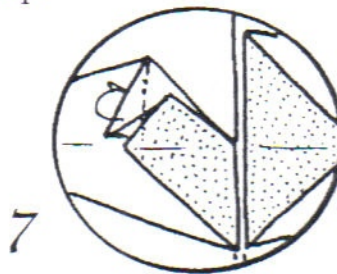

7

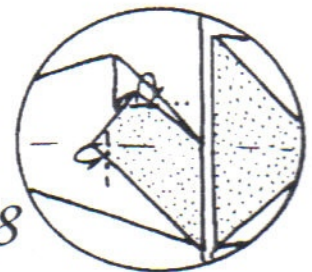

8

Repeat steps 6 to 8  
for the right side.

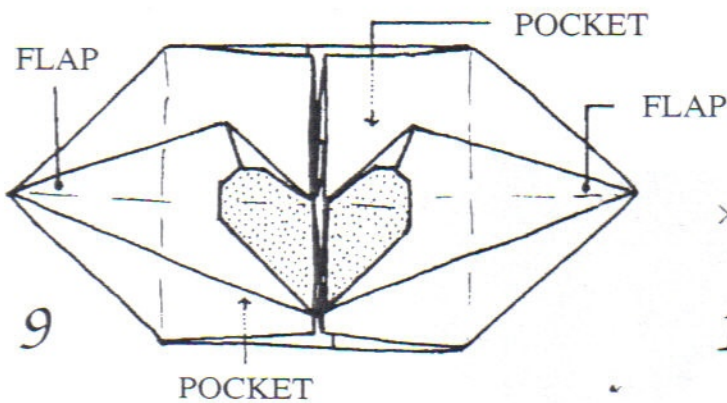

9

1 unit complete.

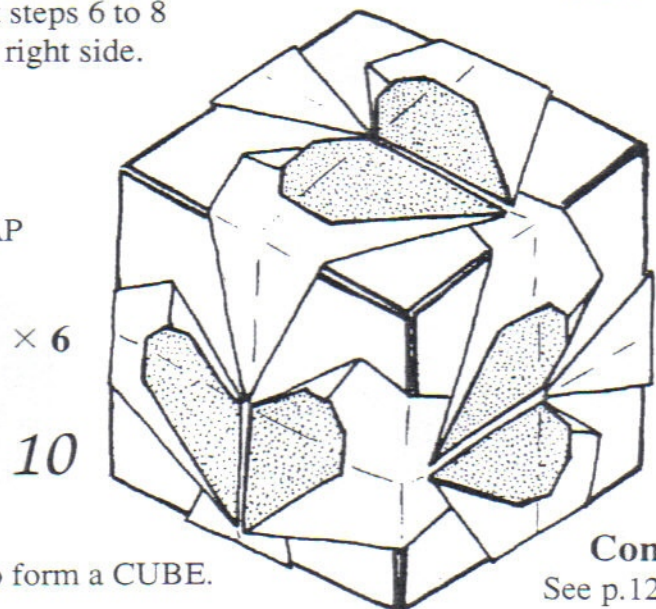

$\times 6$

10

Make 6 to form a CUBE.

**Complete**  
See p.12, no.36

# Generations of Love

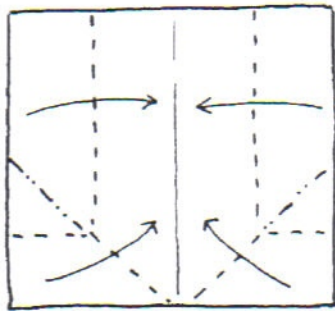

1 White side up.

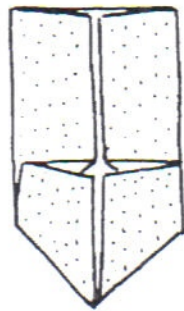

2

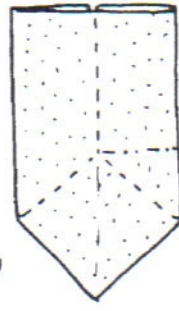

3

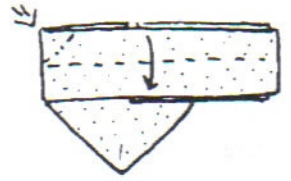

4

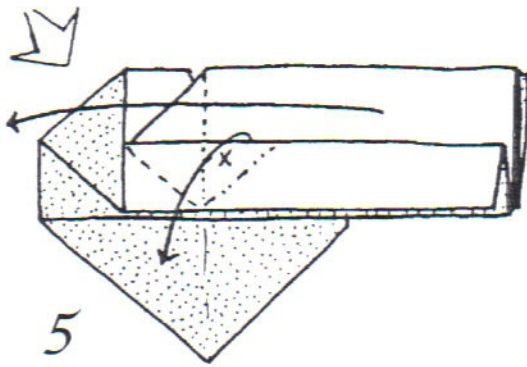

5

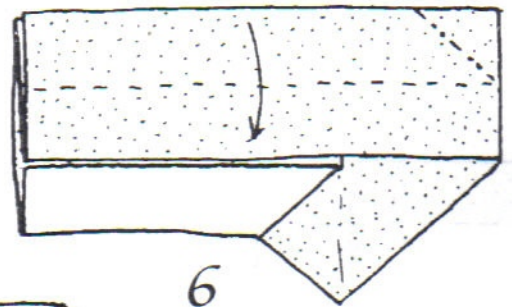

6

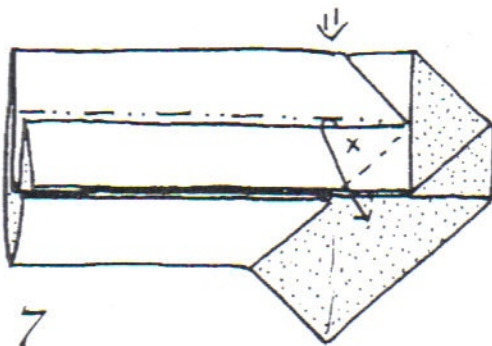

7

Stretch and flatten.

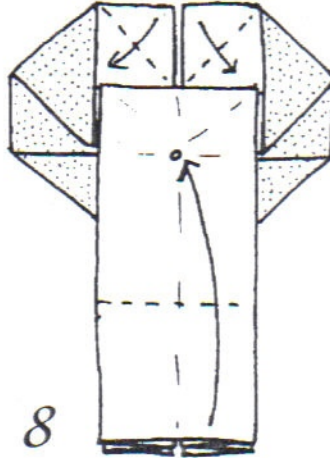

8

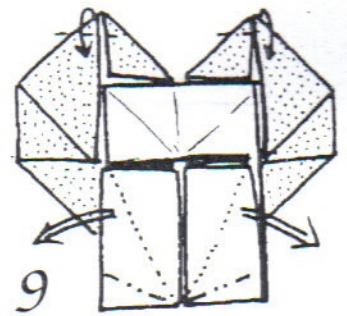

9

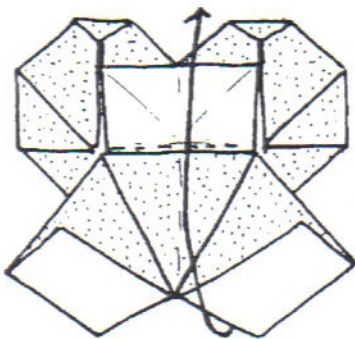

10

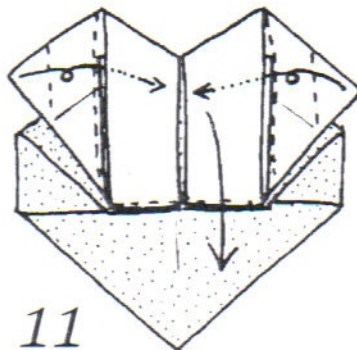

11

Tuck in extra paper and fold down to form the stand.

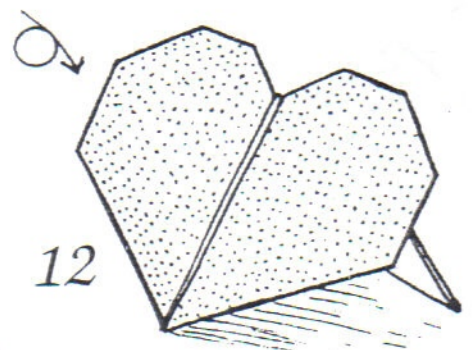

12

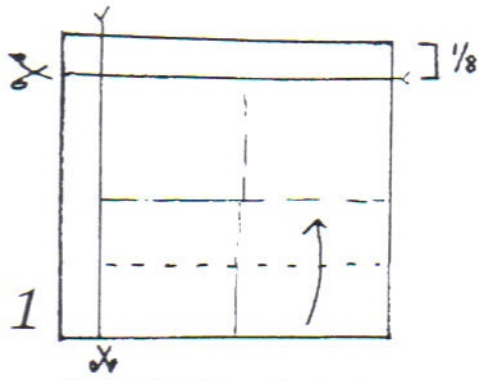

1  
Cut off  $\frac{1}{8}$  on the top and one side the square used in previous heart.

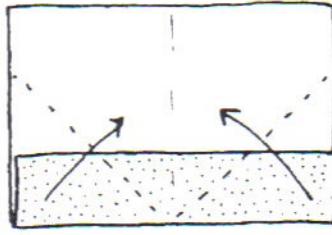

2

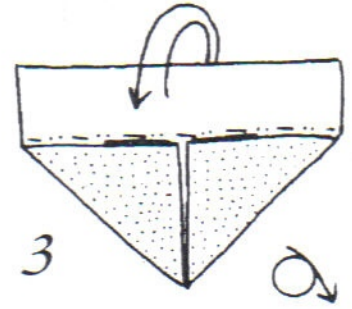

3

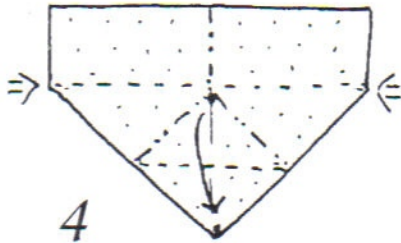

4

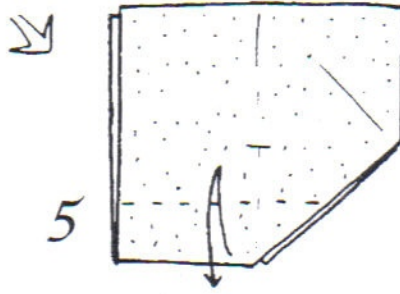

5

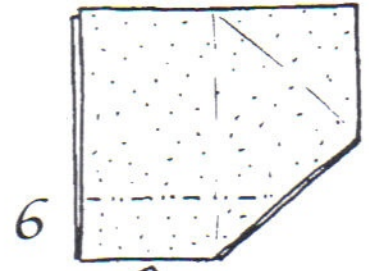

6

Sink.

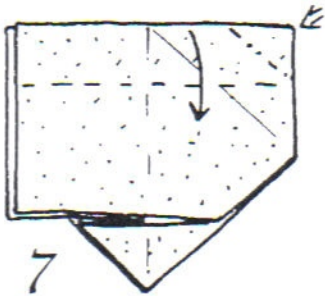

7

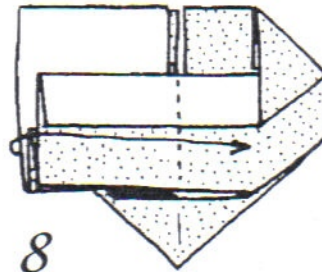

8

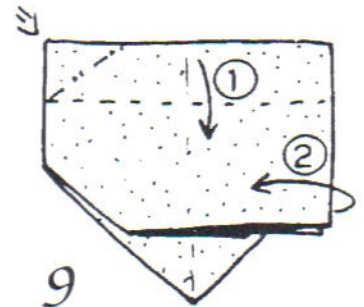

9

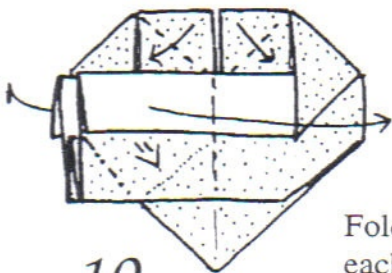

10

Stretch.

Fold more hearts, each smaller than the previous as in step 1.

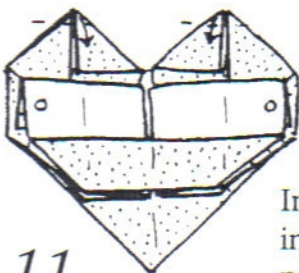

11

Insert flaps into the slot of previous heart.

**Complete**

See p.11, no.29

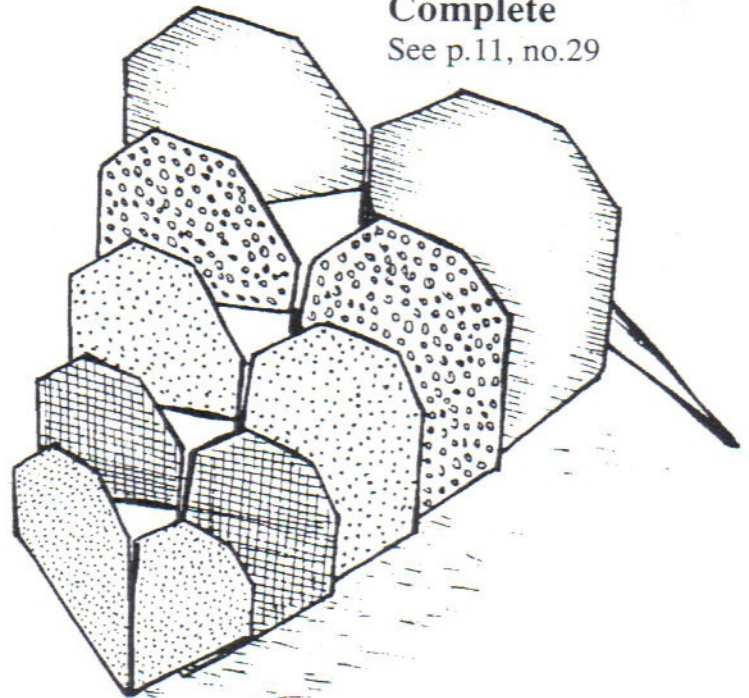



# Heart Frame

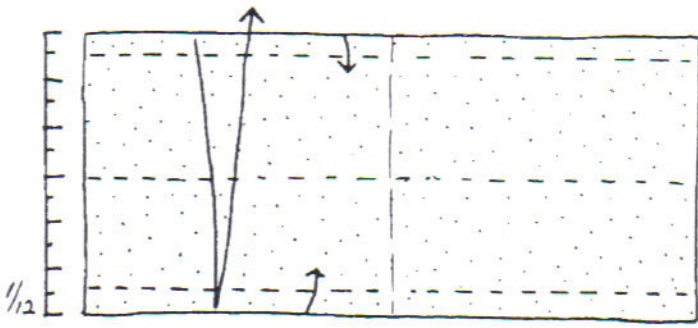

1 Color side up.  
Pre-crease and fold in  
the top and bottom edges.

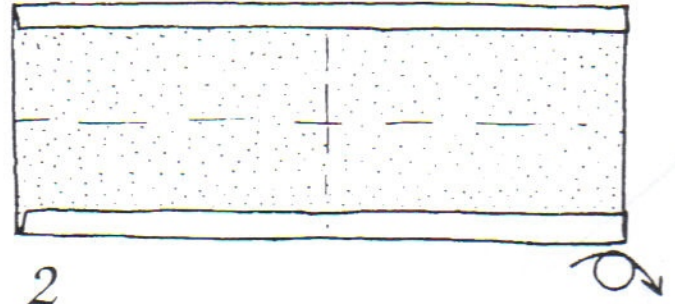

2

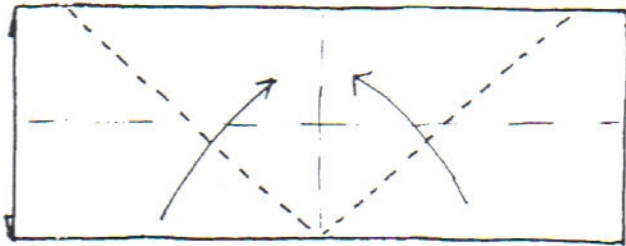

3

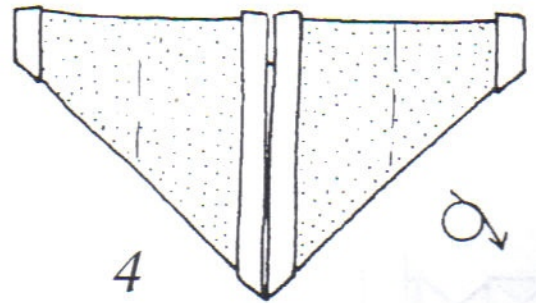

4

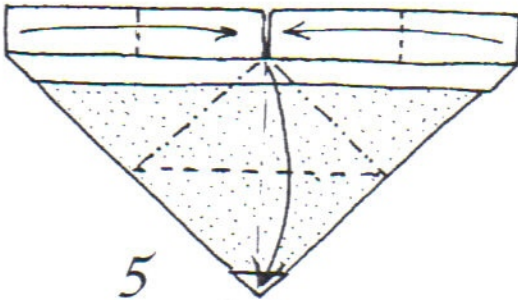

5

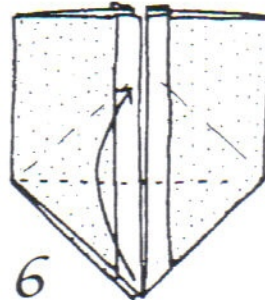

6

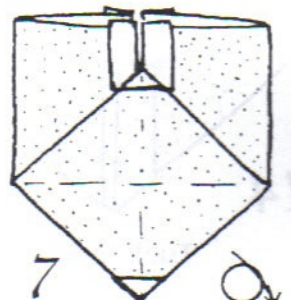

7

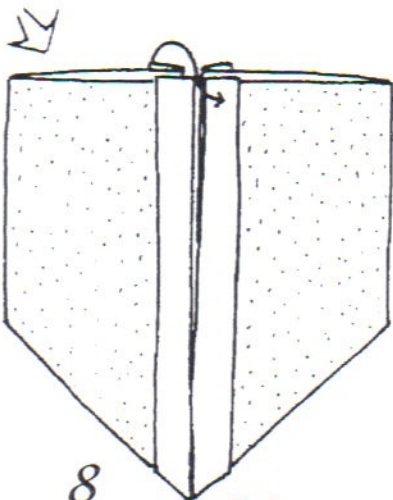

8

Release paper  
from behind.

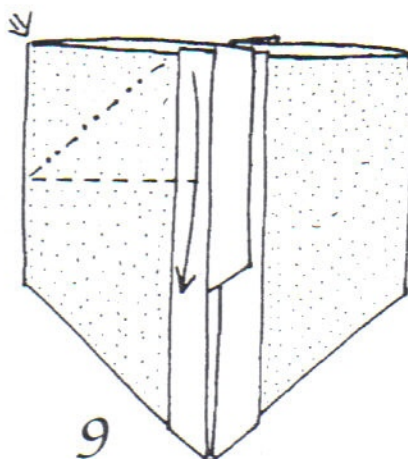

9

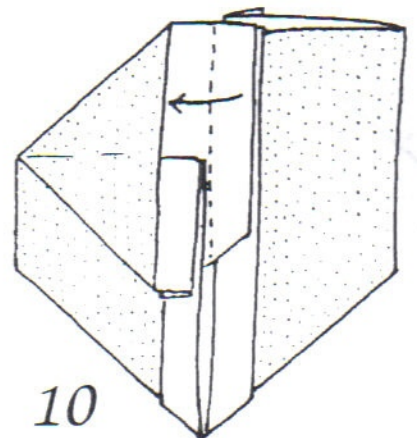

10

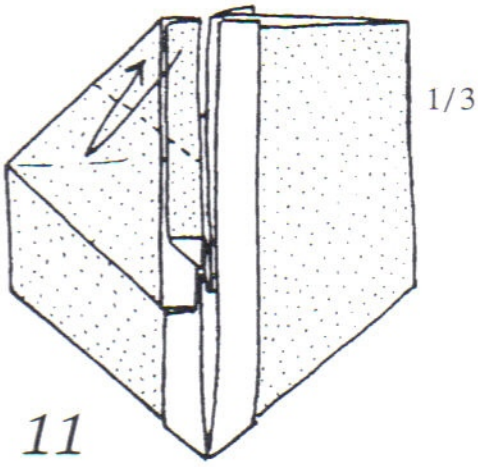

11

Pre-crease.

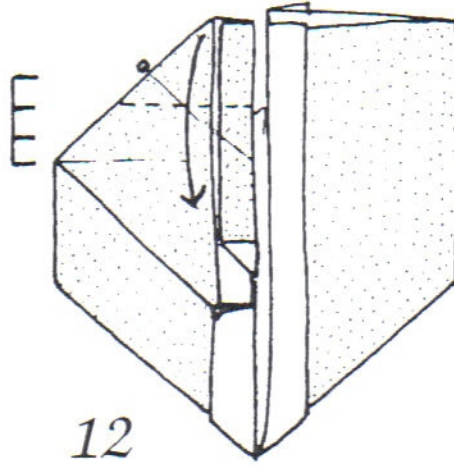

12

NOTE LOCATION POINT.

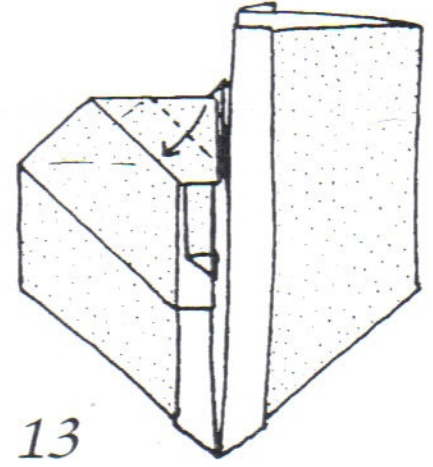

13

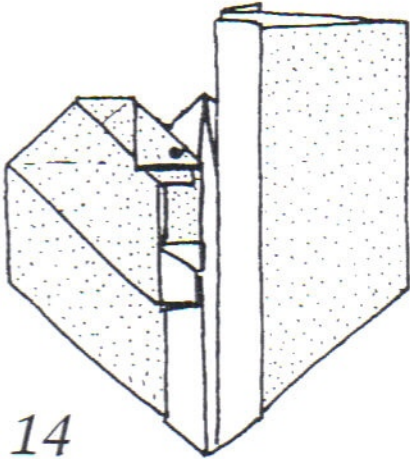

14

Tuck in ● (mark).

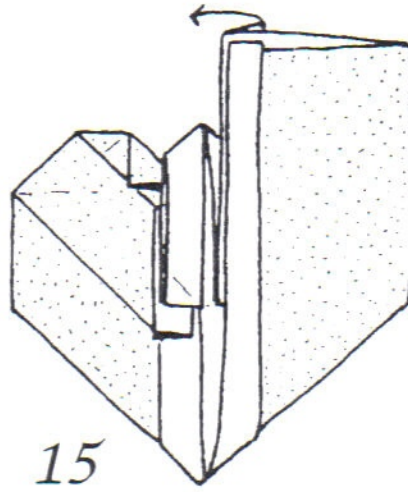

15

Repeat steps 8 to 14  
for the right side.

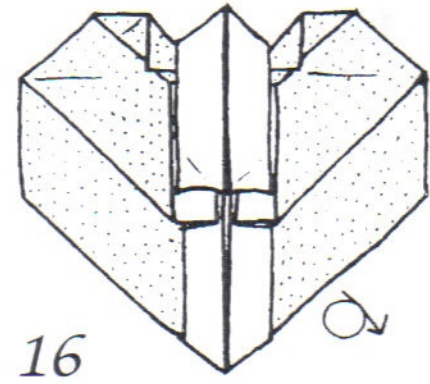

16

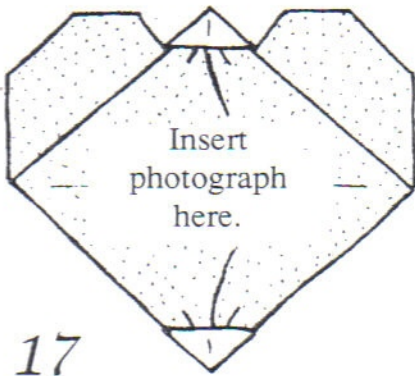

17

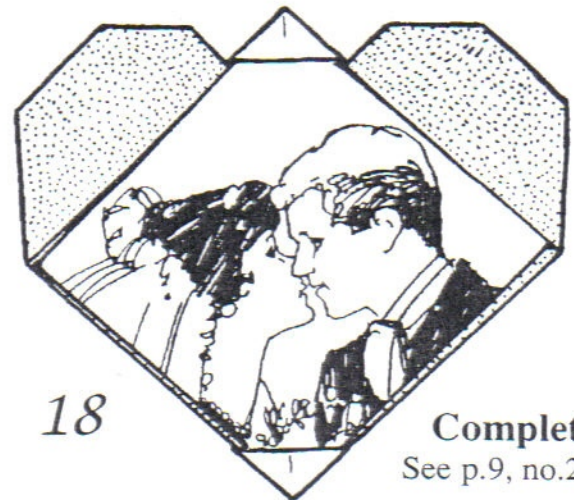

18

Complete  
See p.9, no.22

# Love Triangle

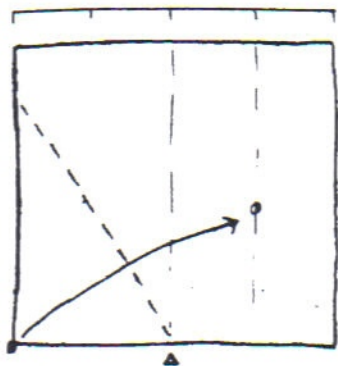

1

White side up.  
Produce 60° creases.

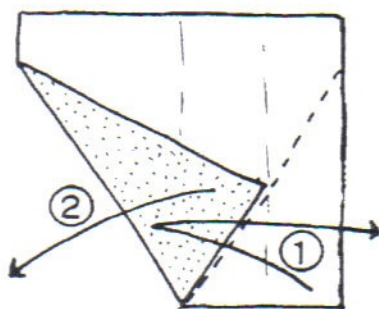

2

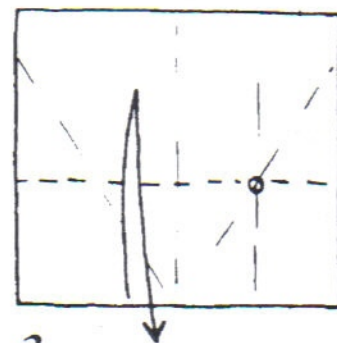

3

NOTE LOCATION POINTS.

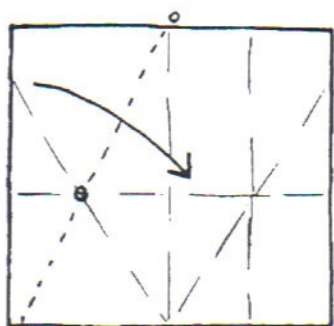

4

NOTE LOCATION POINTS.

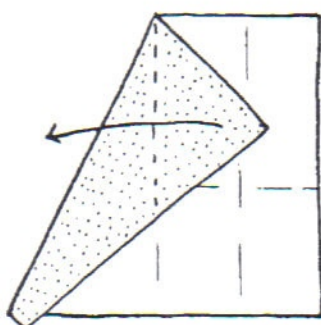

5

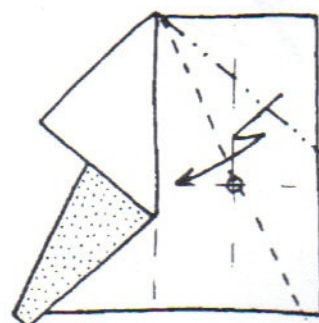

6

Repeat steps 4 and 5  
for the right side.

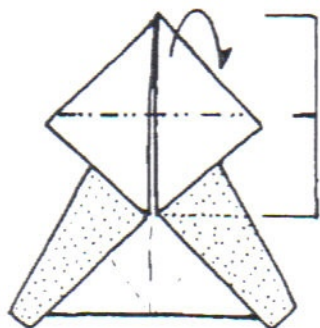

7

NOTE LOCATION POINTS.

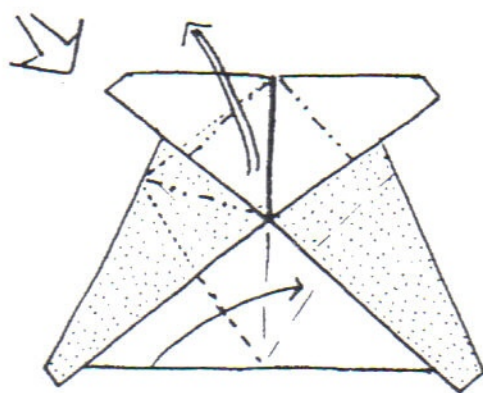

8

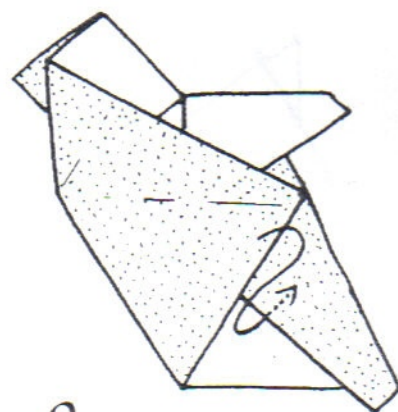

9

Tuck in.

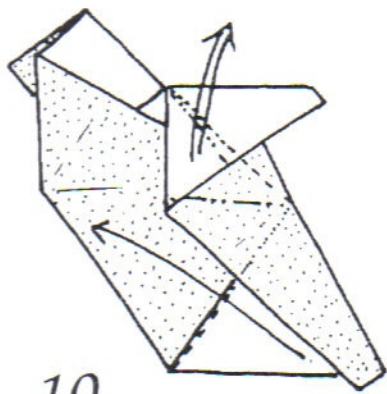

10

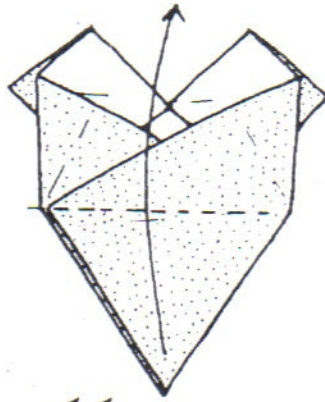

11

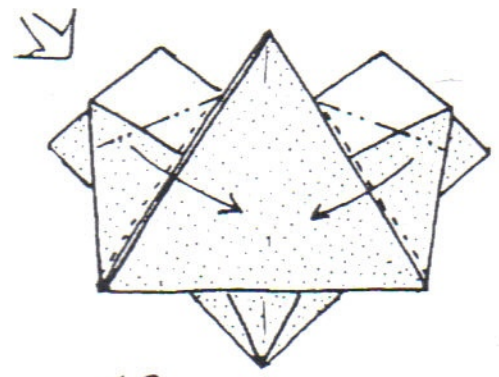

12

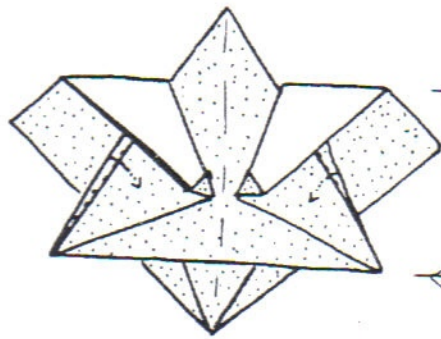

13

PARALLEL

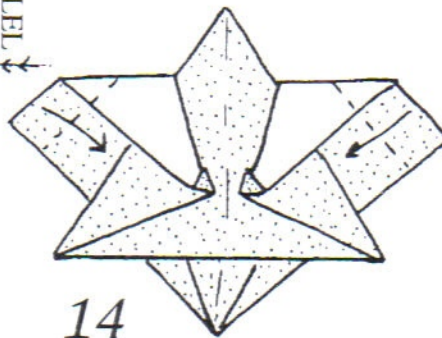

14

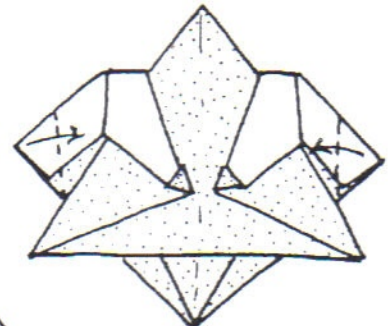

15

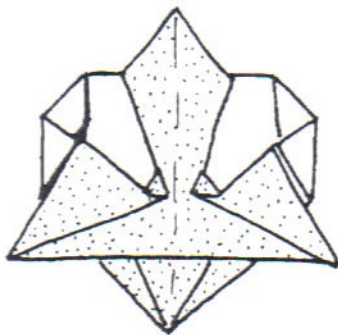

16

9

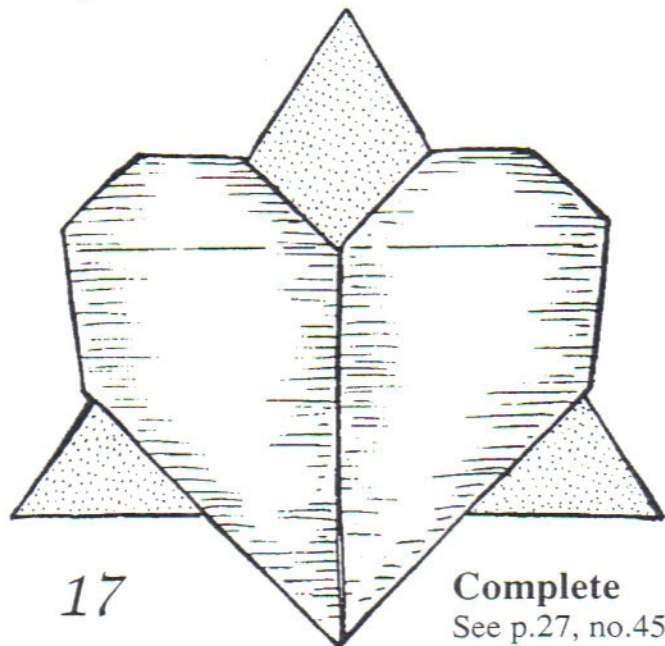

17

Complete  
See p.27, no.45

# Flip-Over Heart

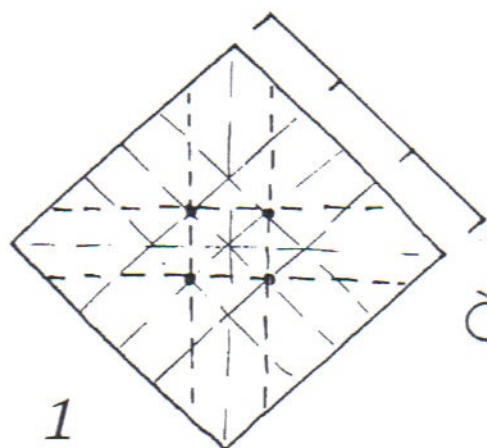

1

White side up.  
Pre-crease.

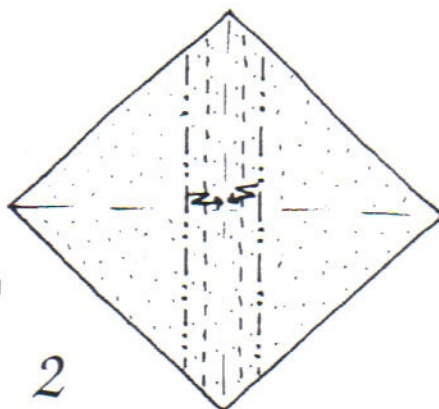

2

Mountain lines  
made in step 1.

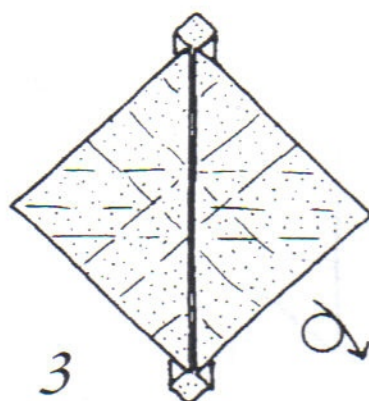

3

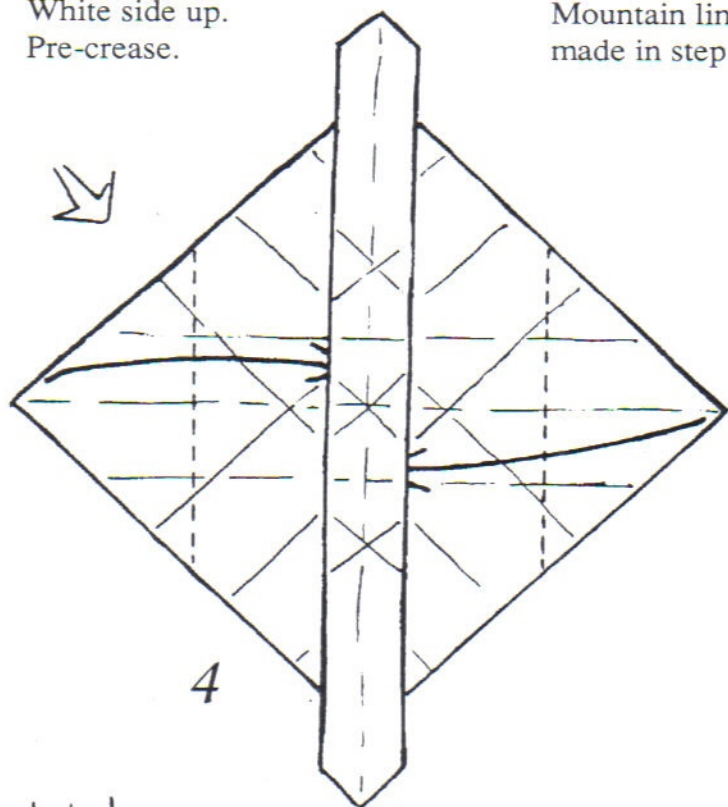

4

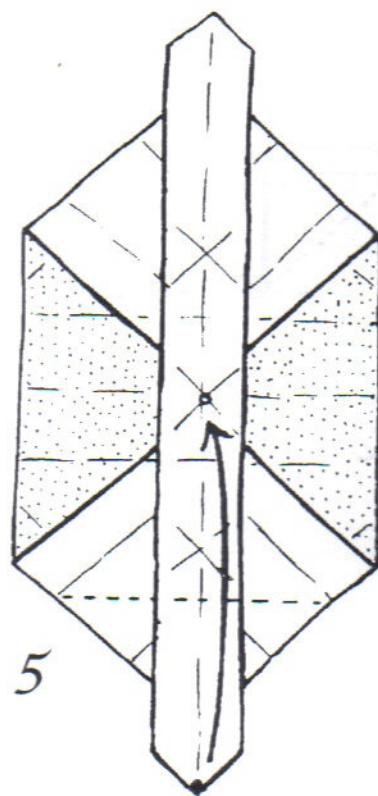

5

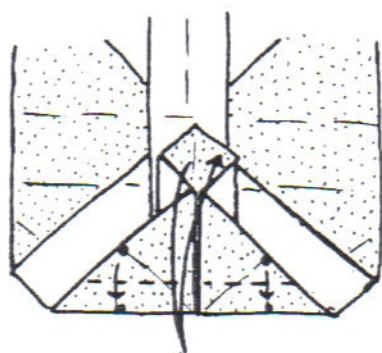

6 Pre-crease.  
NOTE LOCATION POINTS.

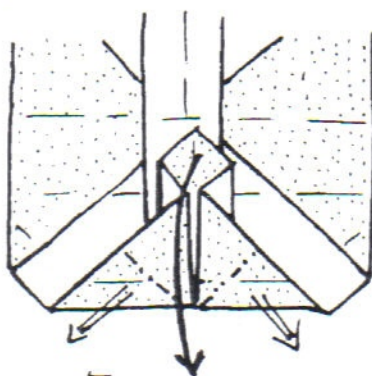

7

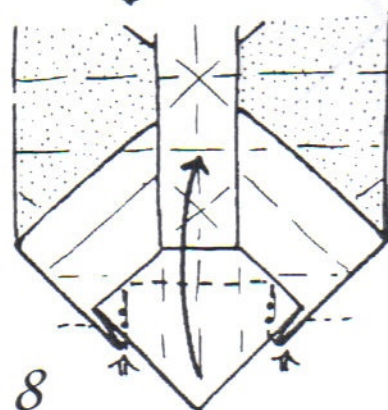

8

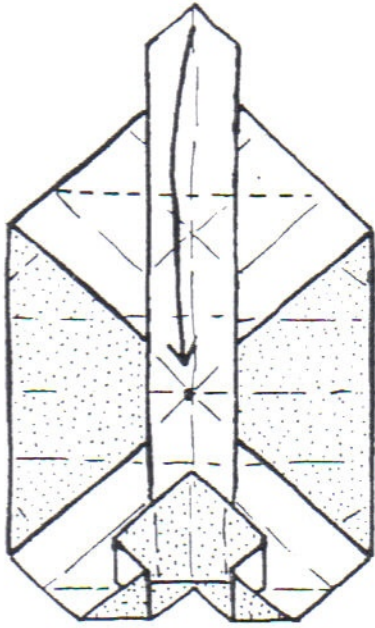

9 Repeat steps 5 to 8 for the top.

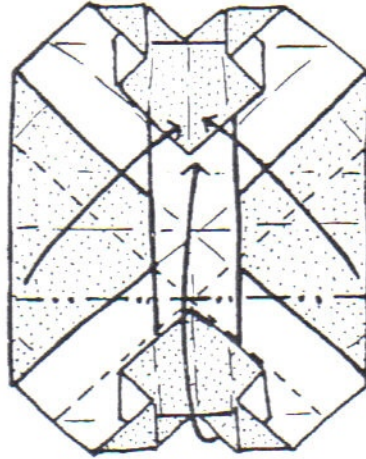

10 Off-set waterbomb base.

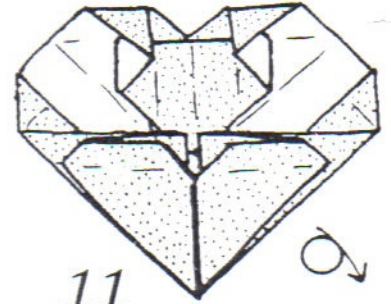

11

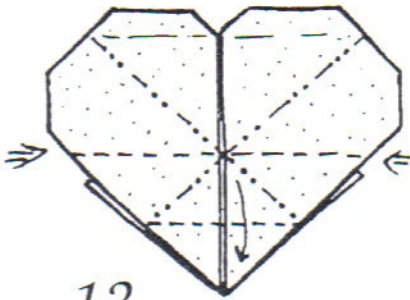

12

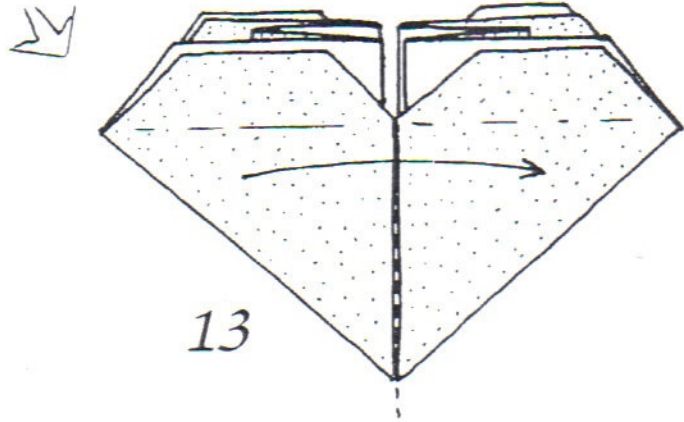

13

Fold 1 flap to the right.

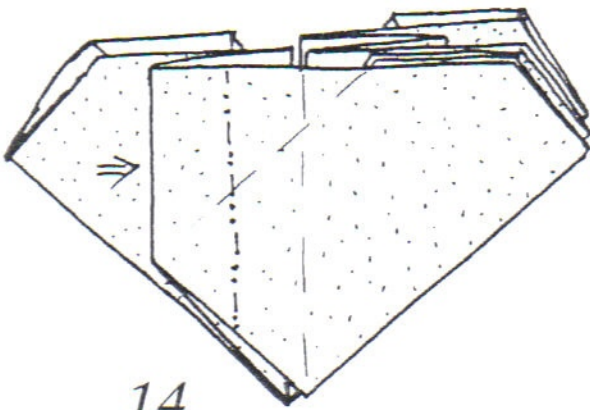

14

Sink.

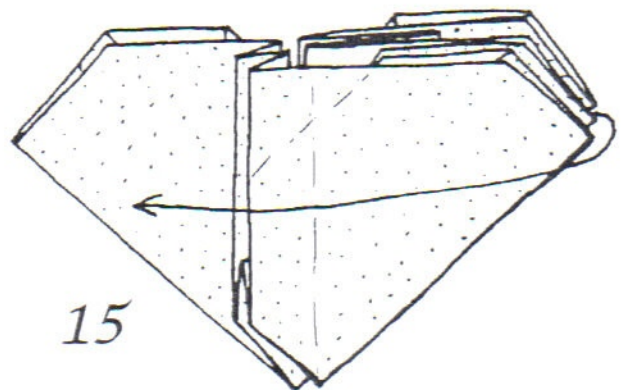

15

Fold 2 flaps to the left. Repeat step 14 then return the flaps to the original place.

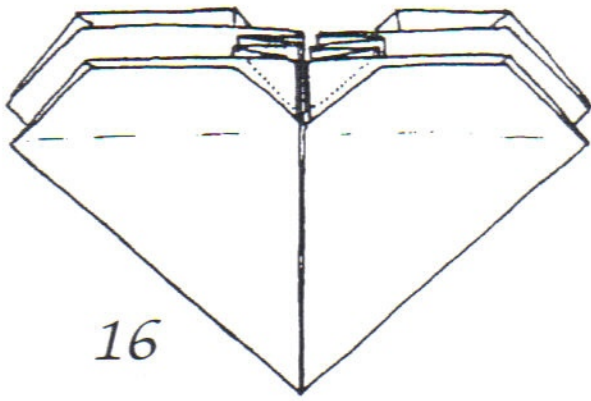

16

Reverse-folds on the central pleats.

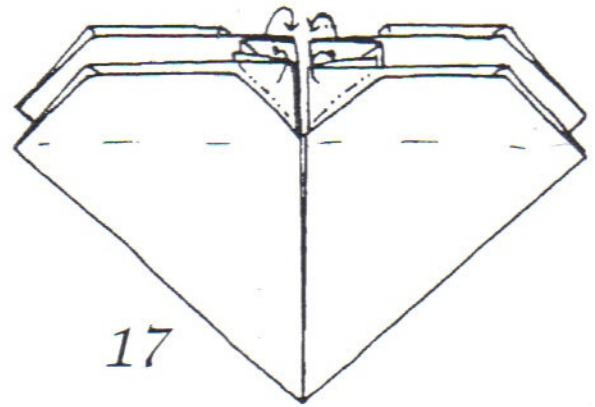

17

Tuck in all the points.

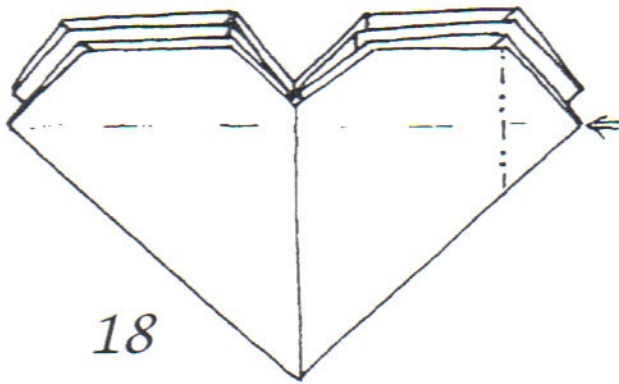

18

Steps 18 to 22 show the shaping of one flap. Repeat for all the flaps.



19



20

Upper layers cut off to show the under layers.

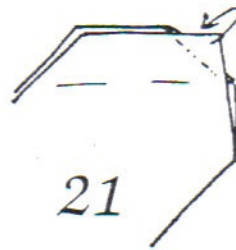

21

Tuck in.



22

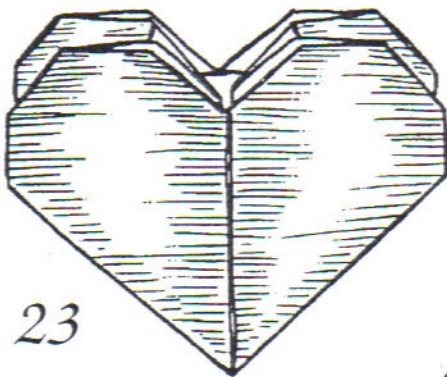

23

**Complete**  
See p.11, no.32

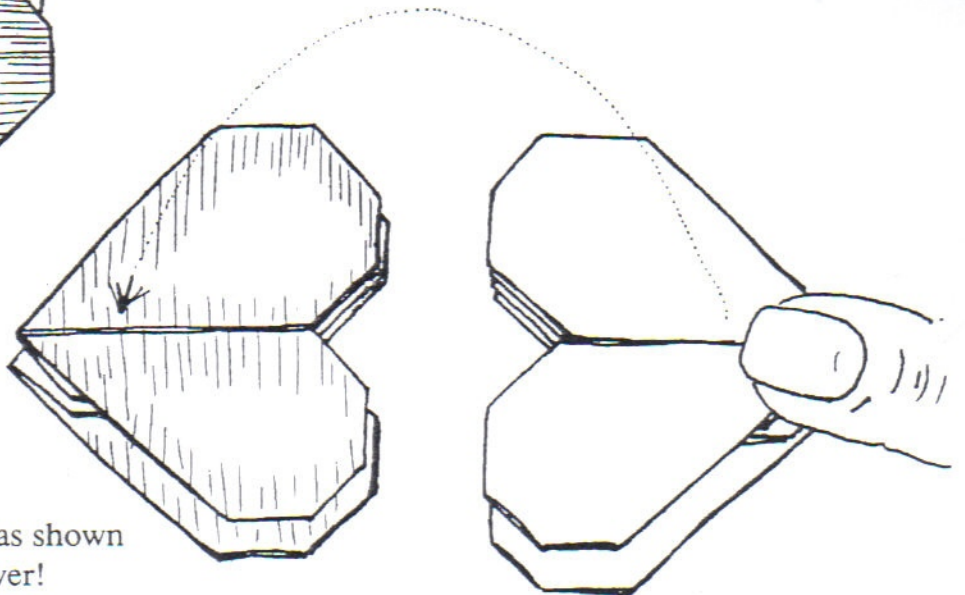

Stroke the heart as shown and it will flip over!

# Photo Frame with Hearts

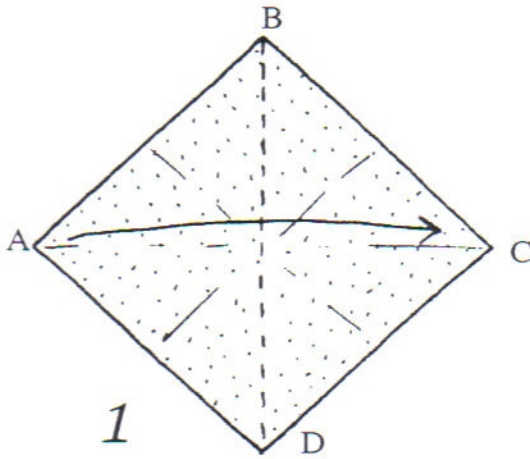

1

Color side up.

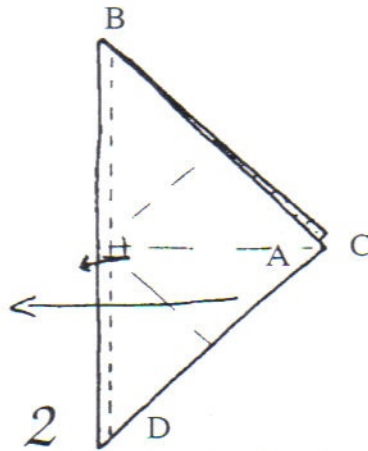

2

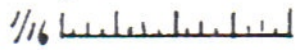

Pre-crease and unfold then fold D to B and repeat the procedure for the other diagonal.

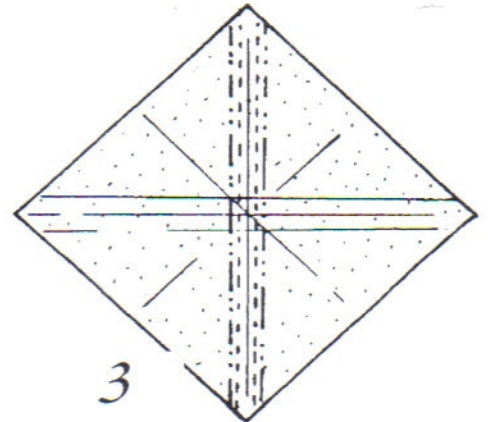

3

Pleat.

(Convert the creases made in step 2 to mountain lines)

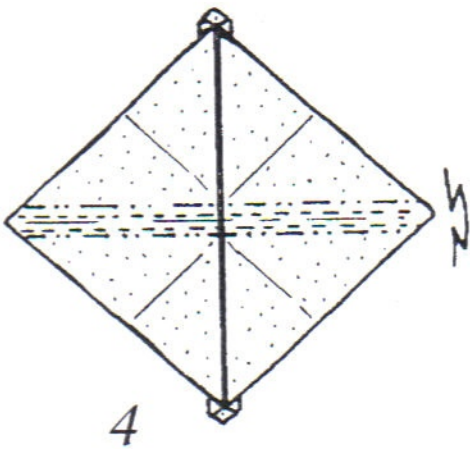

4

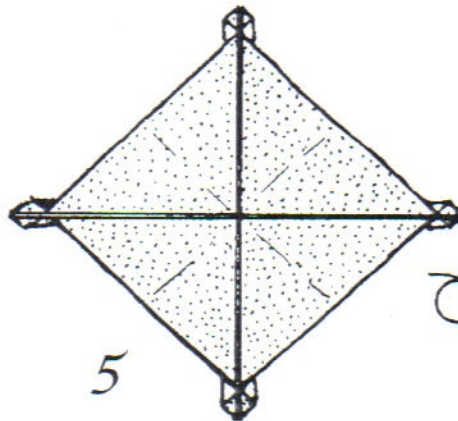

5

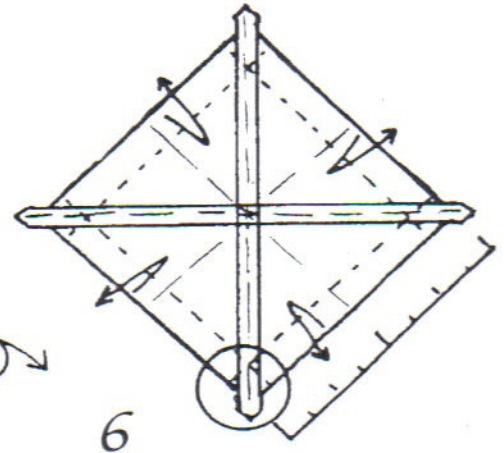

6

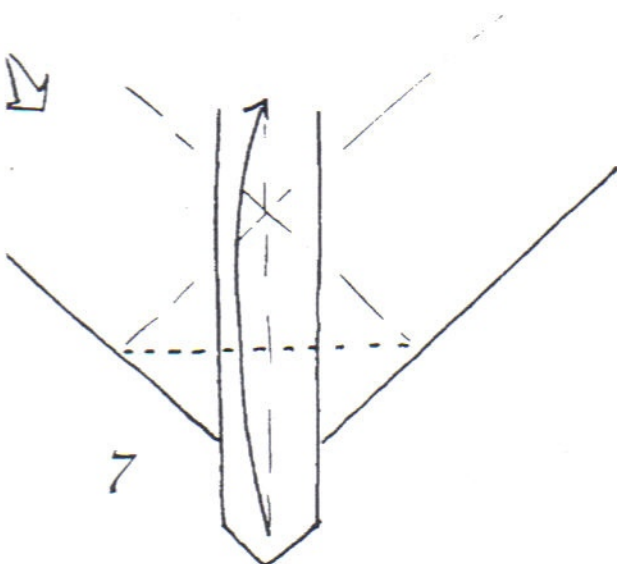

7

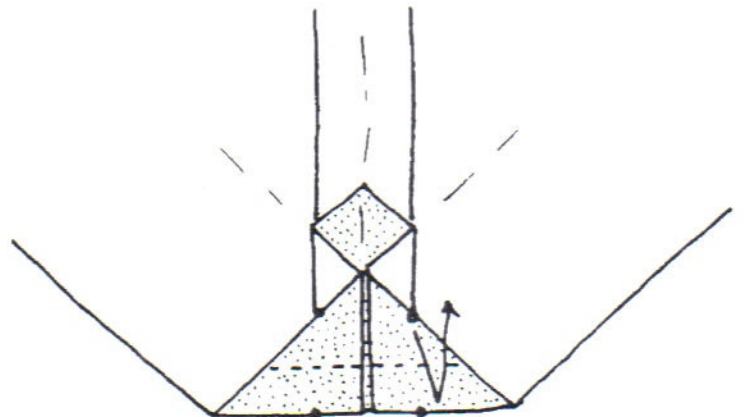

8



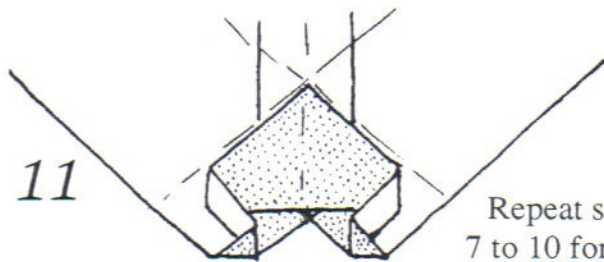
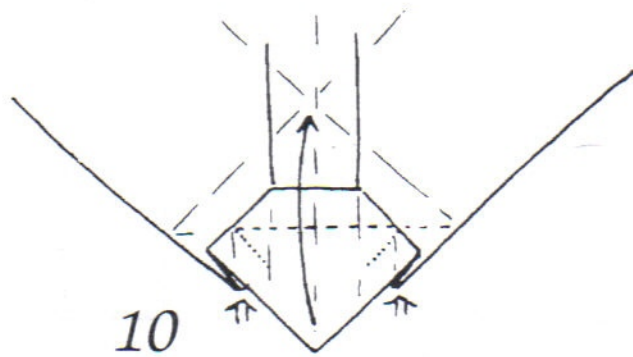
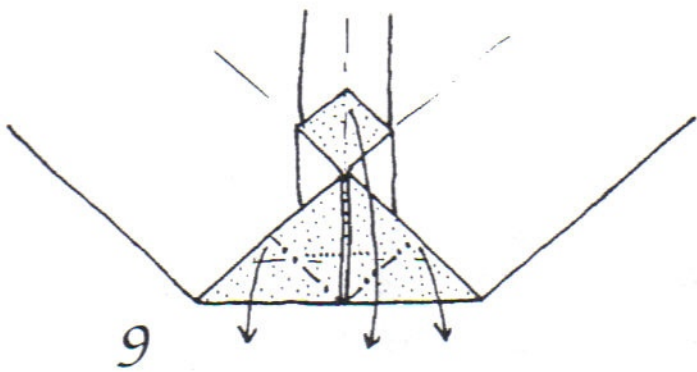

Repeat steps  
7 to 10 for the  
remaining corners.

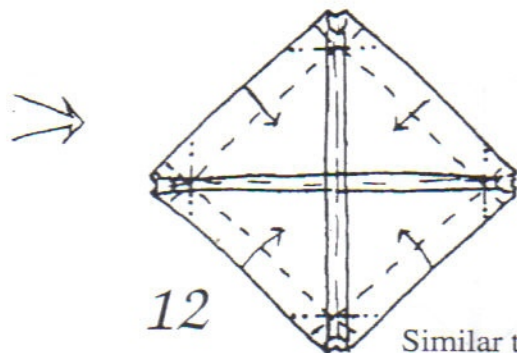

Similar to  
squash Windmill base.

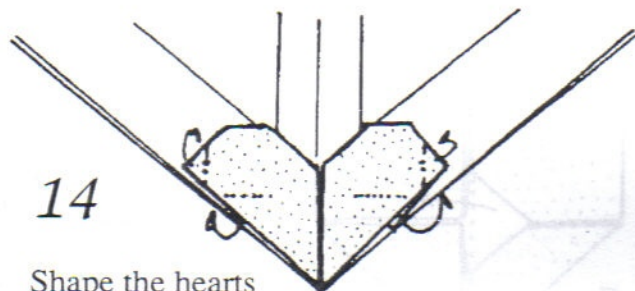
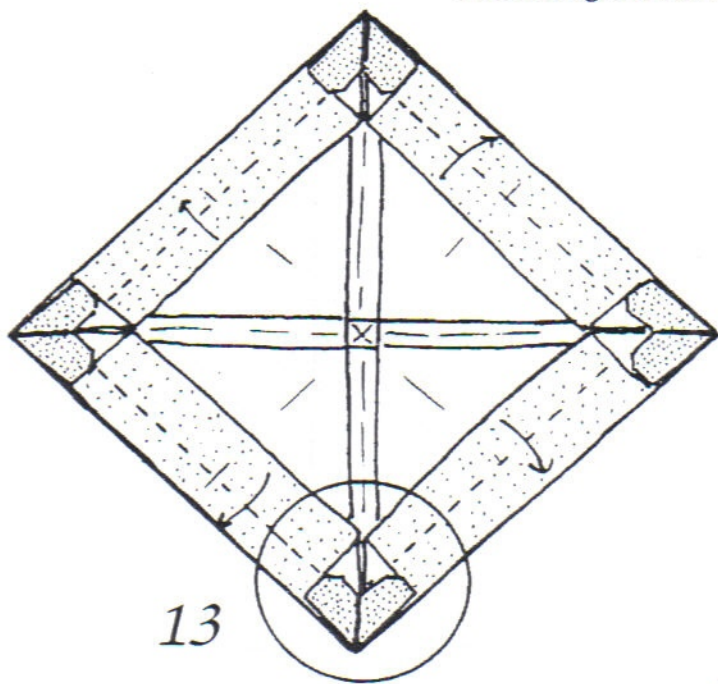

Shape the hearts  
and fold in the flaps to lock the hearts.

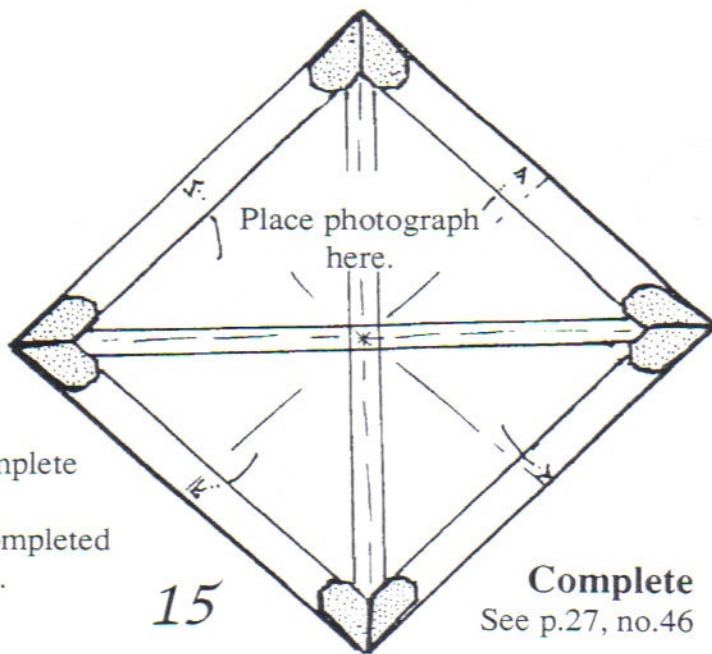

Put in the photograph  
when you reach step 13.  
Continue to step 15 to complete  
the hearts and the frame.  
The diagrams show the completed  
frame without photograph.

**Complete**  
See p.27, no.46

# A Gift of Love

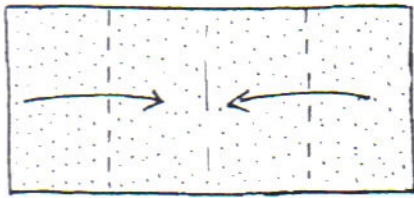

1  $2 \times 1$  rectangle.  
Color side up.

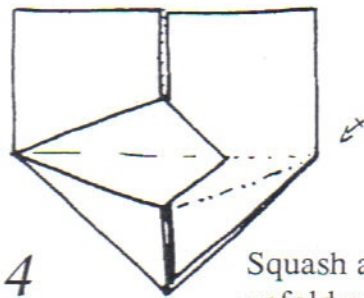
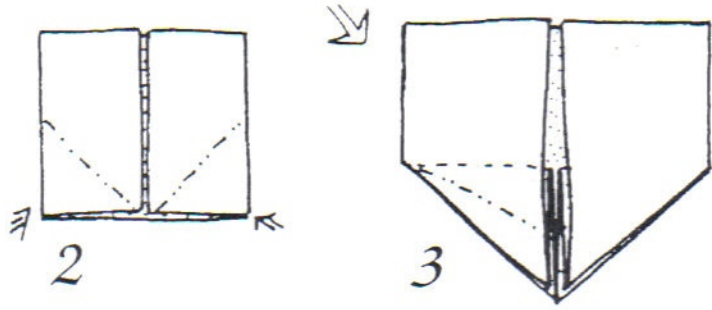

4 Squash and  
unfold with  
white side up.

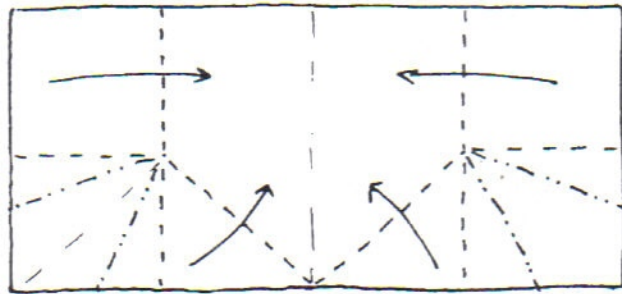

5 Refold.

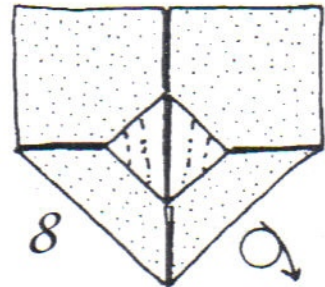
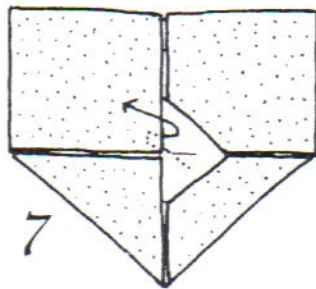
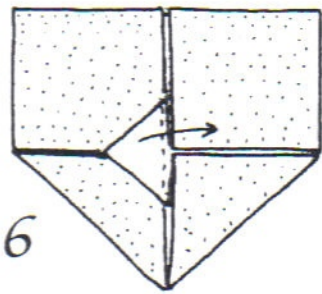

Bring out the flap from below.

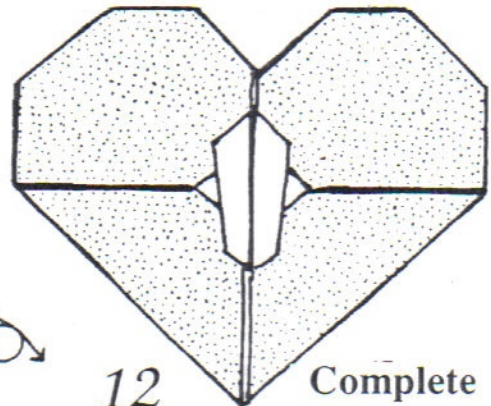
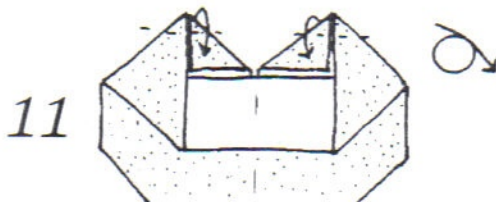
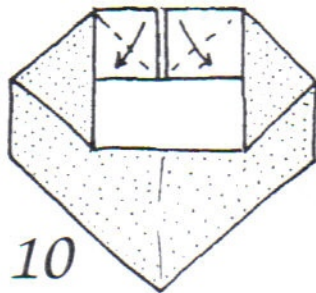
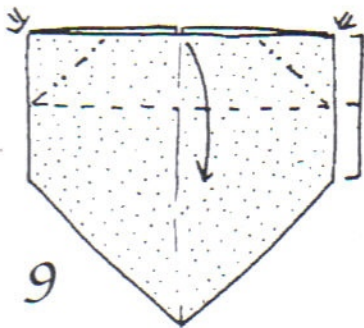

12 **Complete**  
See p.5, no.1

# Heart Ring 1

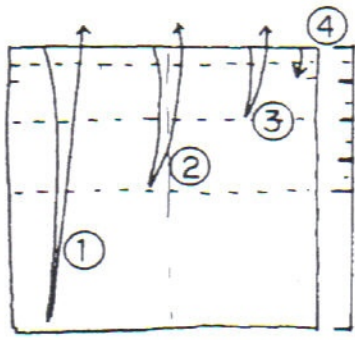

1 White side up.

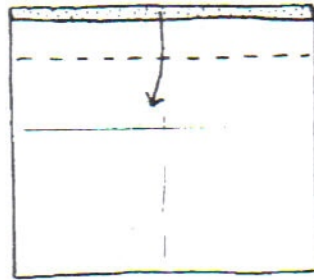

2 Fold along the crease line made in step 1 (2).

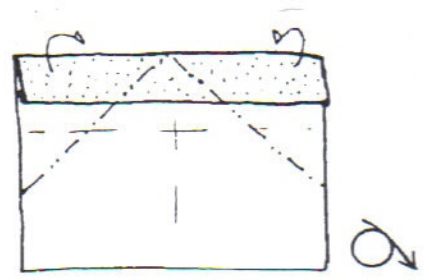

3

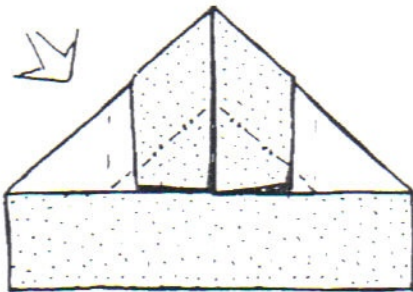

4 Reverse-folds.

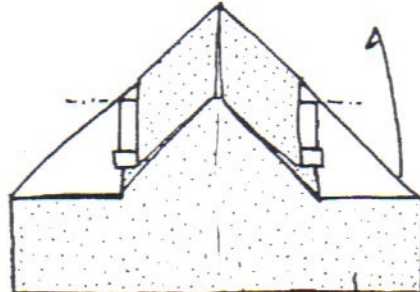

5

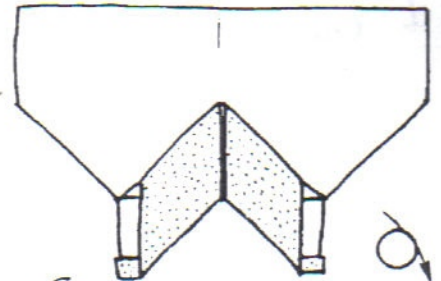

6

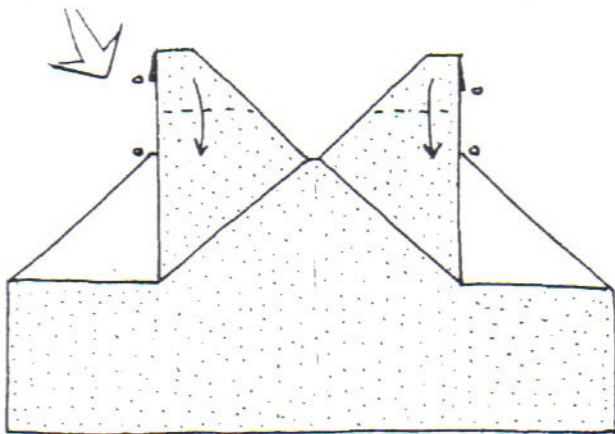

7 NOTE LOCATION POINTS.

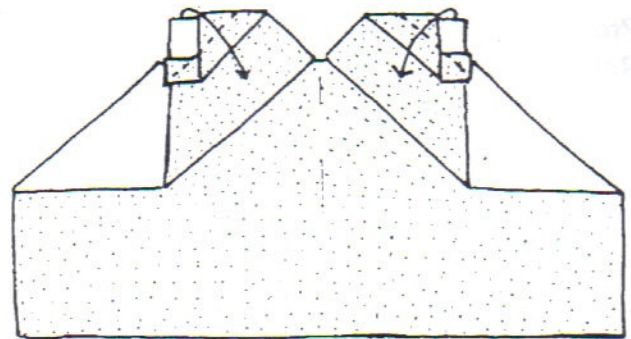

8

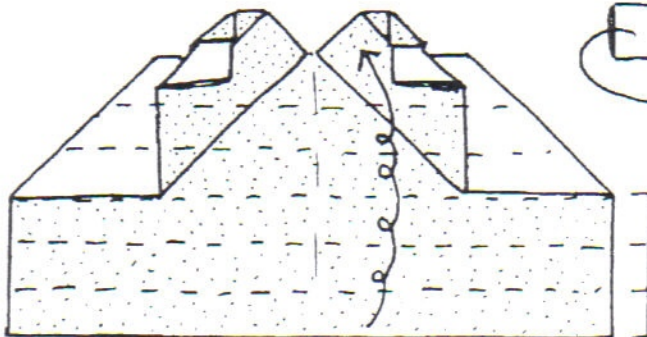

9

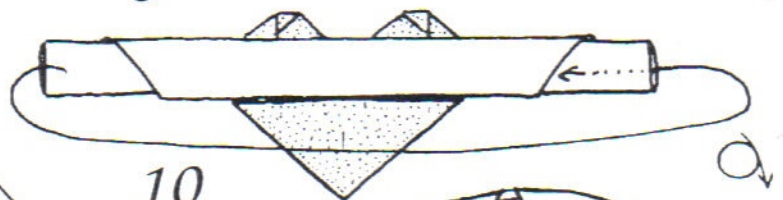

10  
Insert to  
form a ring.

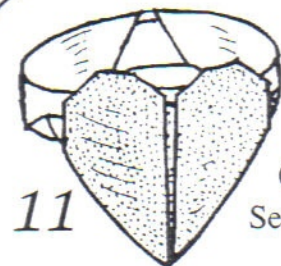

11

**Complete**  
See p.7, no.13

# Heart Ring 2

Model: David Petty  
 Drawings and  
 Modifications: Francis Ow

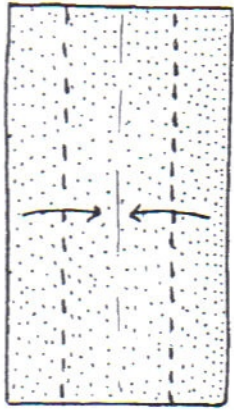

1 1 × 2 rectangle.  
 Color side up.



2

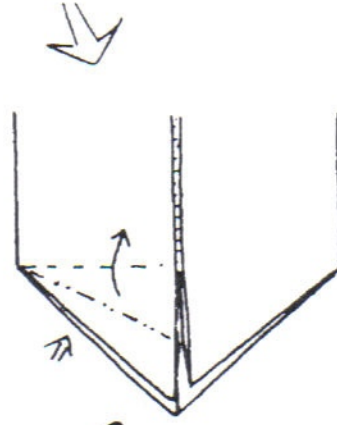

3

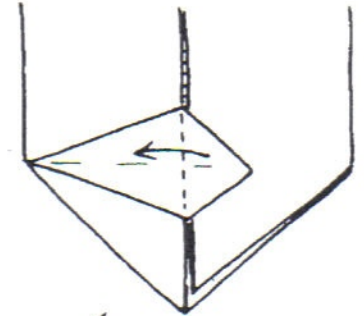

4

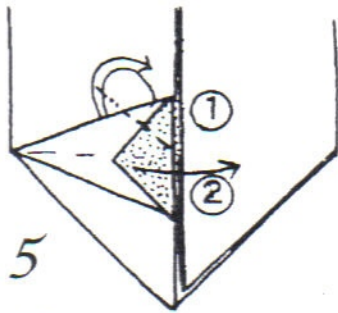

5  
 1. Pre-crease (Mountain).  
 2. Return to step 4.

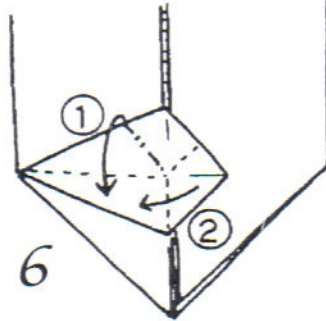

6

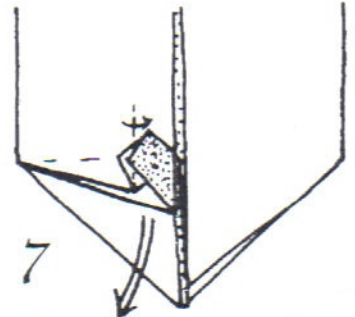

7  
 Release paper from below.

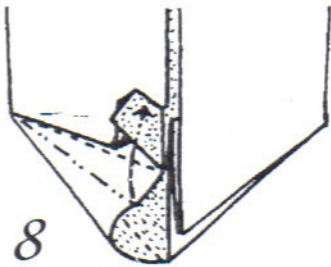

8

Tuck under.

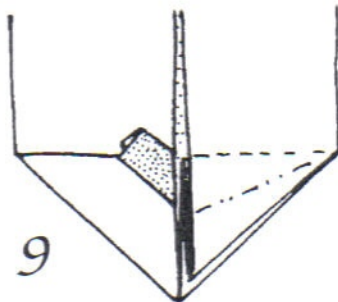

9

Repeat steps 3 to 8  
 for the right side.

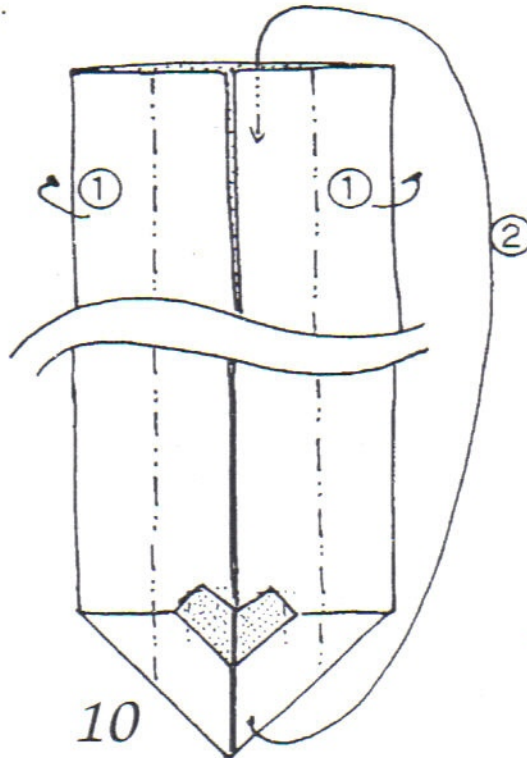

10

Mountain-fold and  
 insert to form a ring.

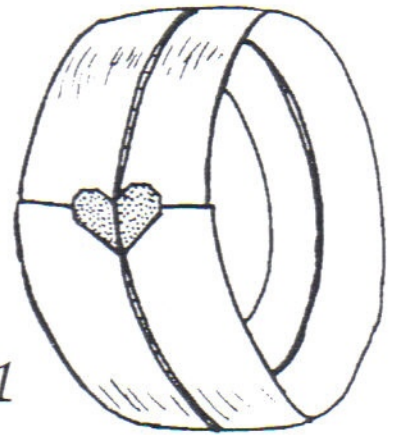

11

Complete  
 See p.7, no.11

# Bigamous

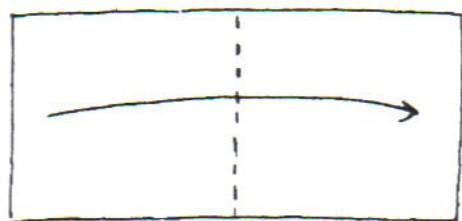

1 2 × 1 rectangle.  
White side up.

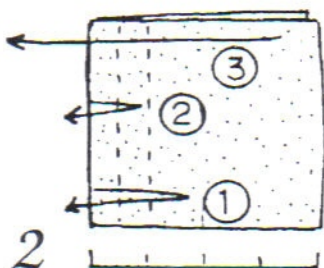

2

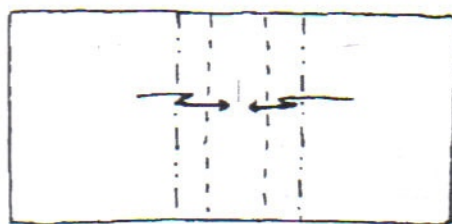

3

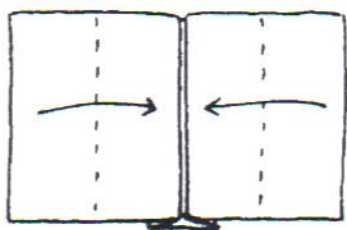

4

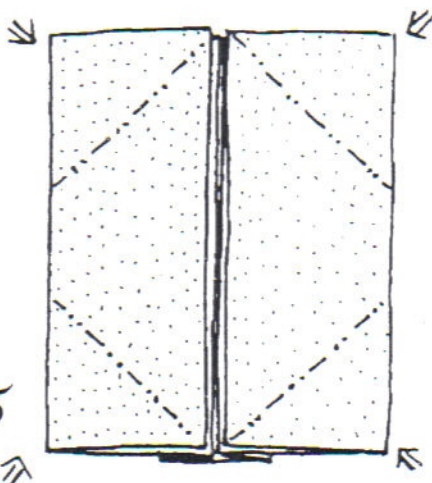

5

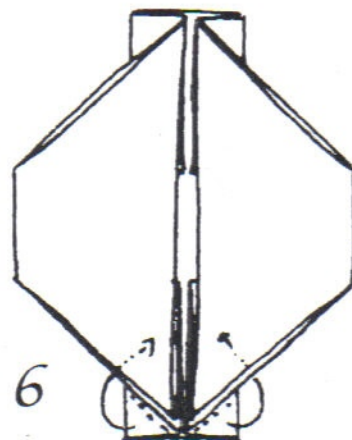

6

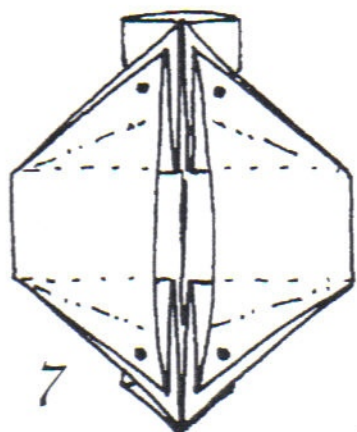

7

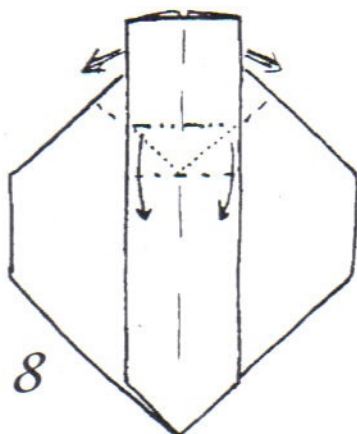

8

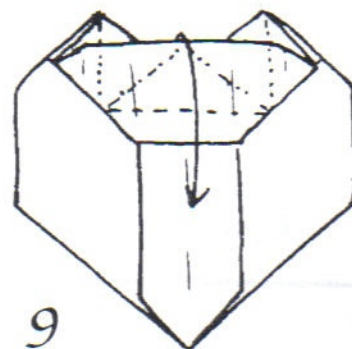

9

Fold as in steps 3 to 9  
of HEART RING 2 (Page 42)  
for the 4 indicated flaps to make 2 small hearts.

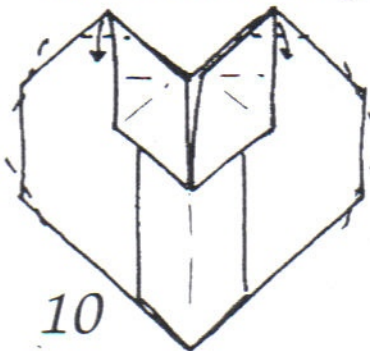

10

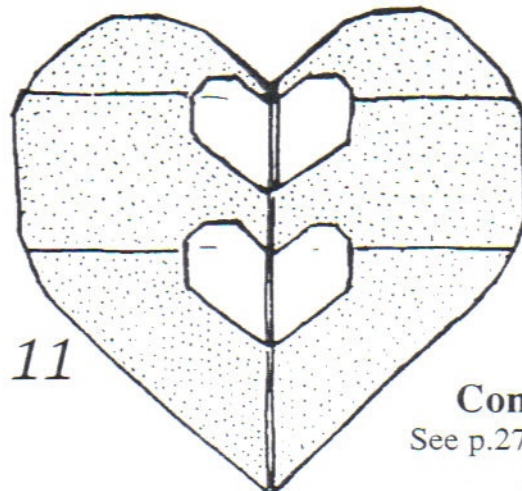

11

Steps 8 to 10 show the folding  
of the main Hearts.

**Complete**  
See p.27, no.48

# Heart on Heart

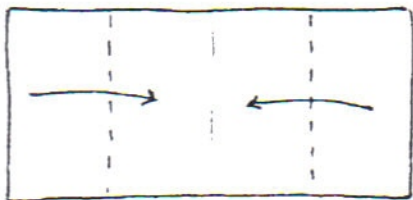

1 2 × 1 rectangle. White side up. Fold as in HEART RING 2 (Page 42).

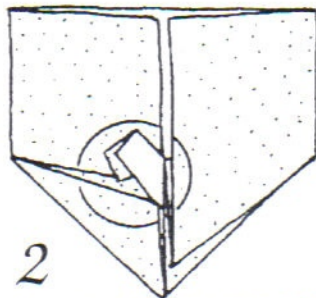

2

Step 7 of HEART RING 2 (Page 42). Shape the Heart as shown.

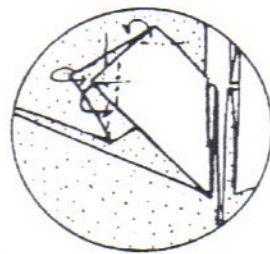

3

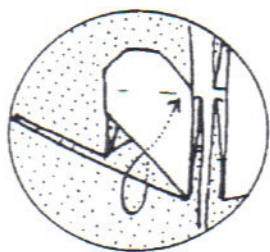

4

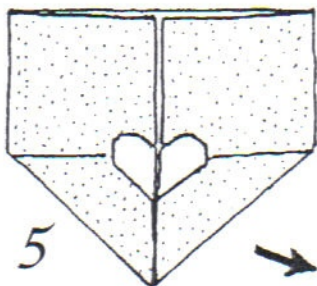

5

Step 10 of HEART RING 2. Turn over and fold the larger heart. Refer to steps 9 to 11 of A GIFT OF LOVE (Page 40).

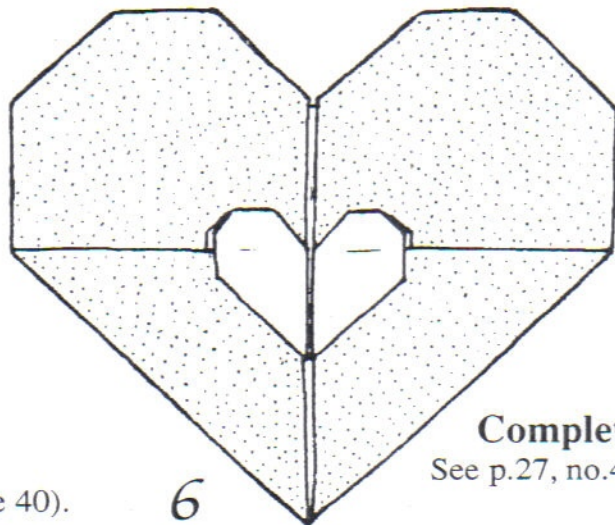

6

**Complete**  
See p.27, no.47

# Lover's Hat

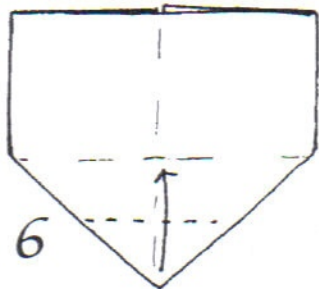

6

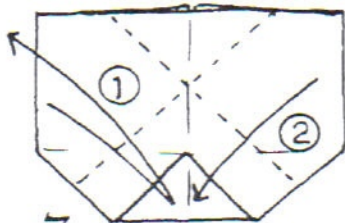

7

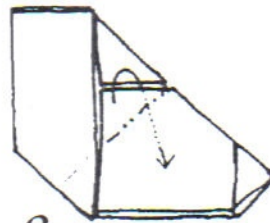

8

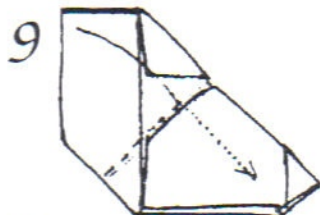

9

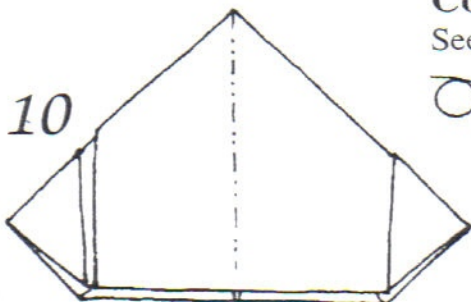

10

**Complete**  
See p.6, no.6

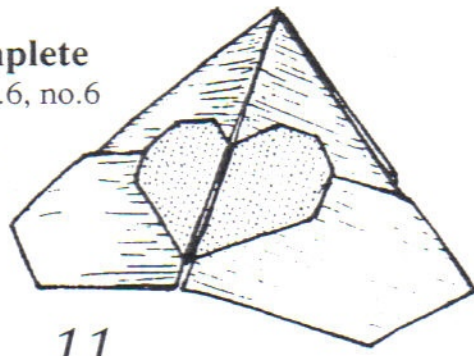

11

# Love Cap

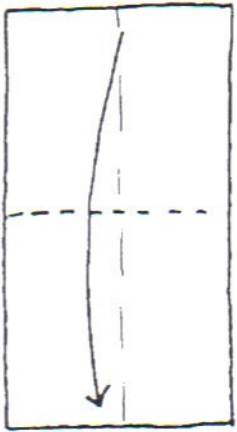

1 1 × 2 rectangle.  
White side up.

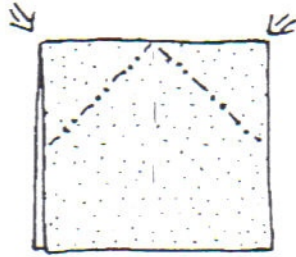

2

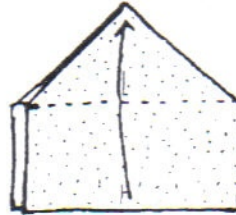

3



4

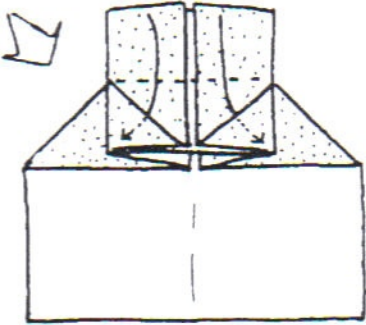

5 Fold down and  
tuck into pockets.

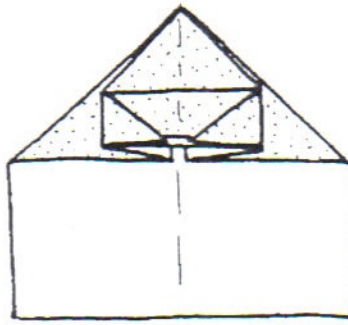

6

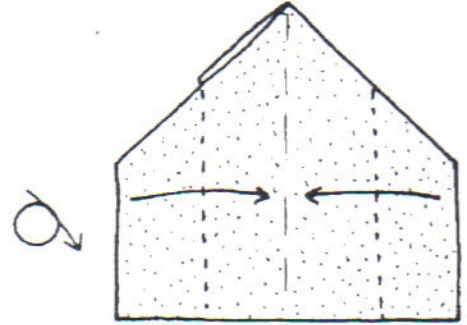

7

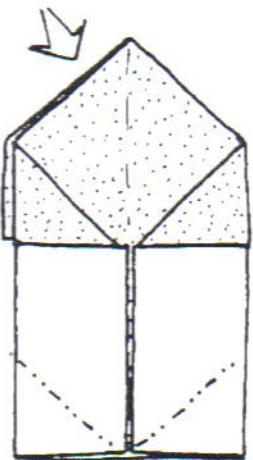

8 Form Heart.  
Refer to steps  
3 to 9 of  
HEART RING 2  
(Page 42).

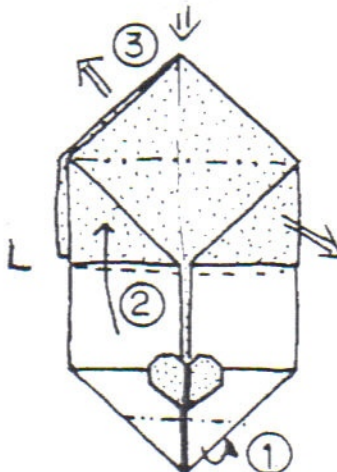

9

1. Mountain-fold.
2. Fold up 90°.
3. Open to form  
the cap.

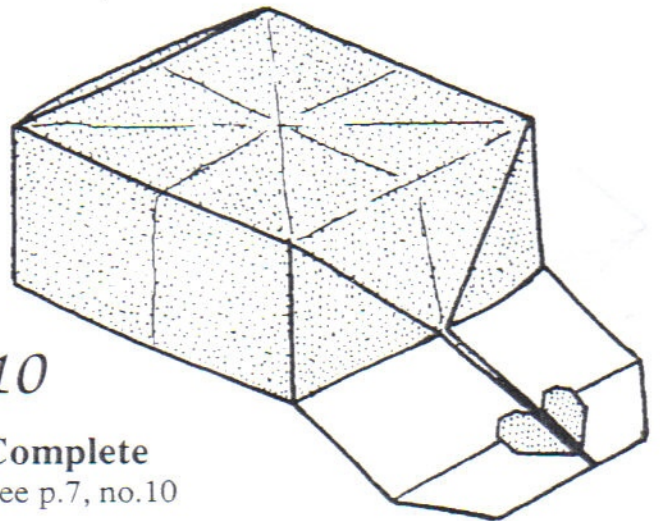

10

**Complete**  
See p.7, no.10

# Half-Hearted

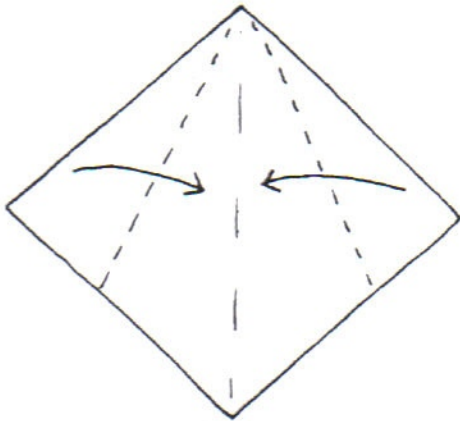

1 White side up.

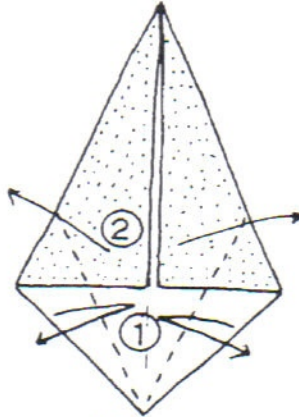

2 1. Pre-crease.  
2. Unfold.

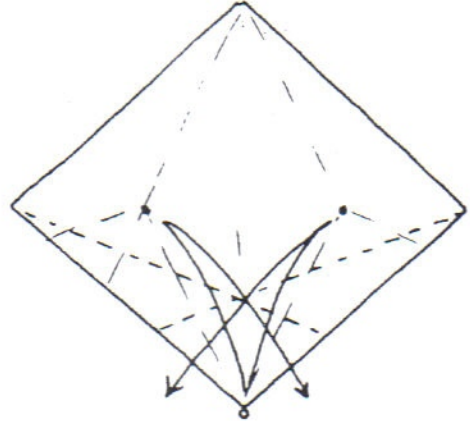

3 Pre-crease.

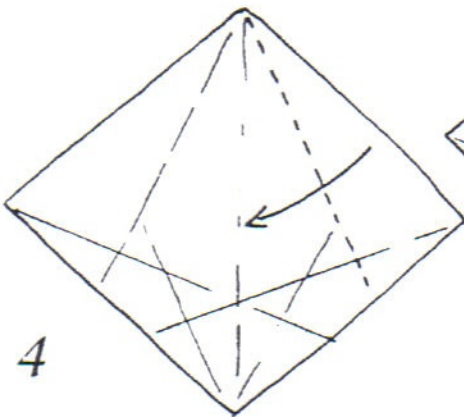

4

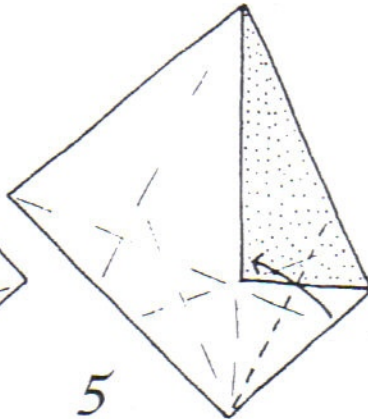

5

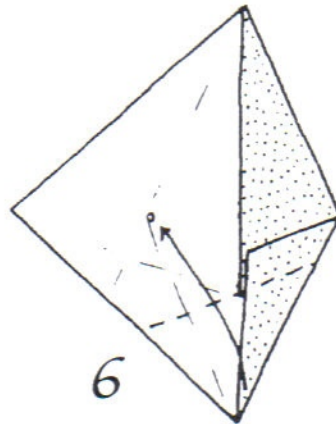

6

Refold along the creases.

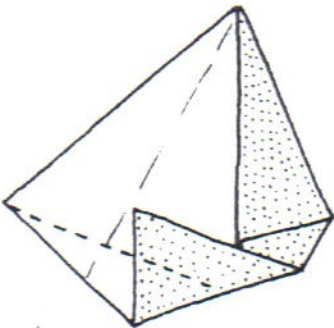

7

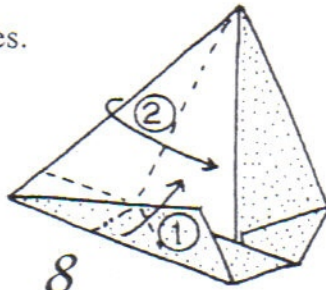

8

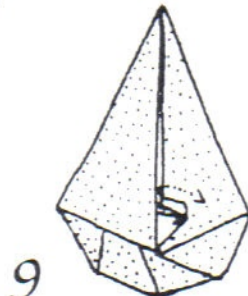

9

Tuck in.

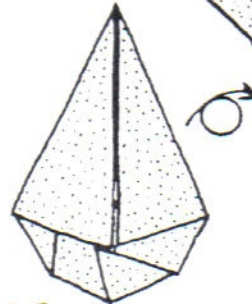

10

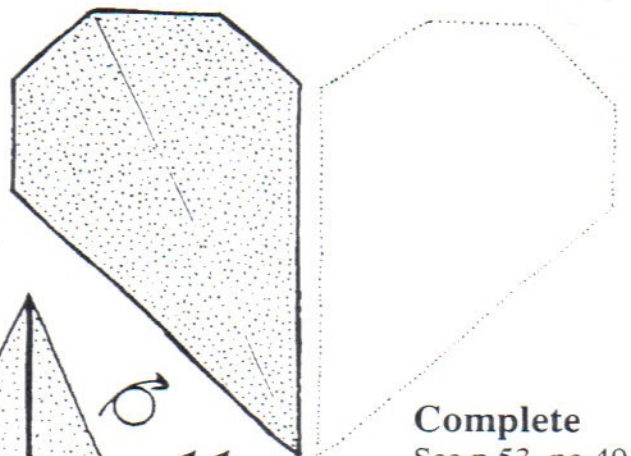

11

Make one more  
to complete  
the other half  
of the heart.

**Complete**  
See p.53, no.49



# Pockets for Half-Hearted

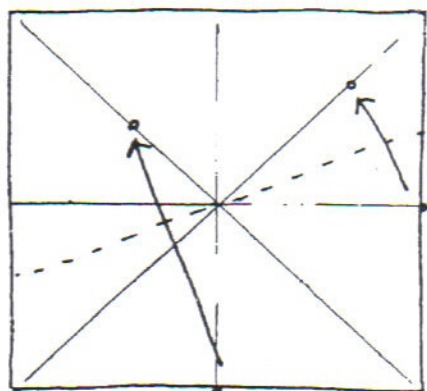

1 White side up.

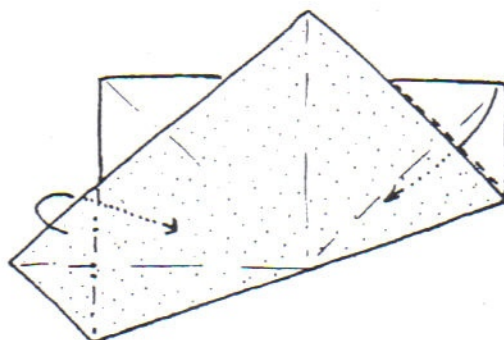

2

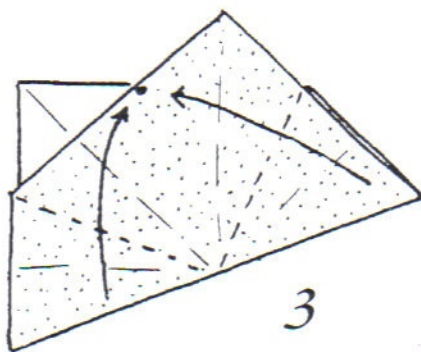

3

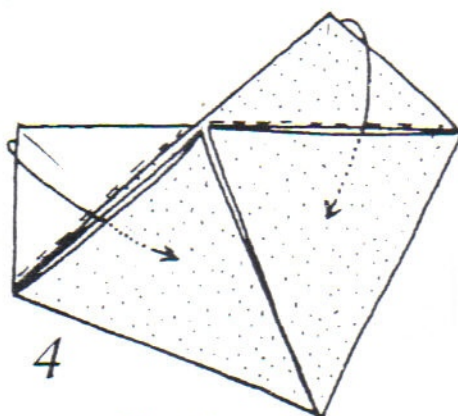

4

Tuck in.

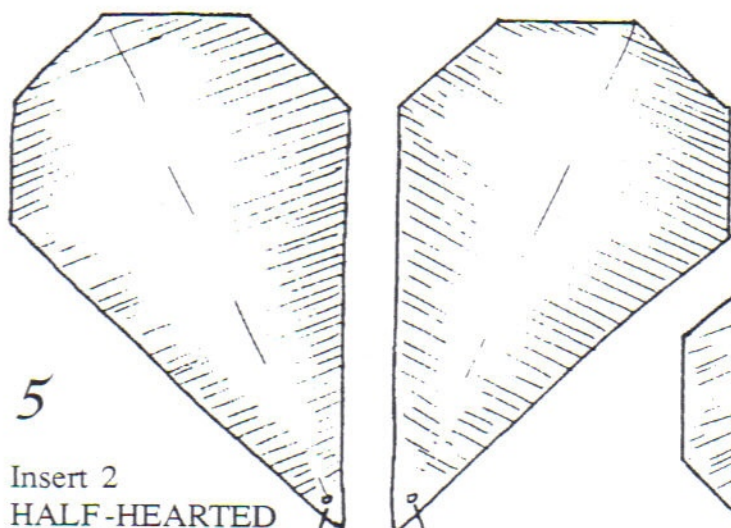

5

Insert 2  
HALF-HEARTED  
modules into  
the pockets.

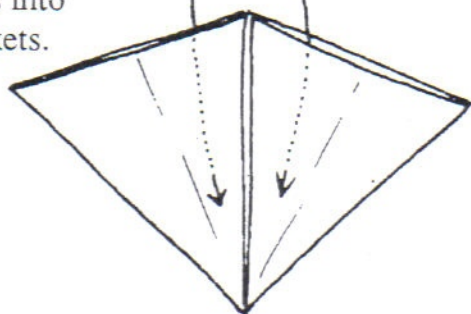

6

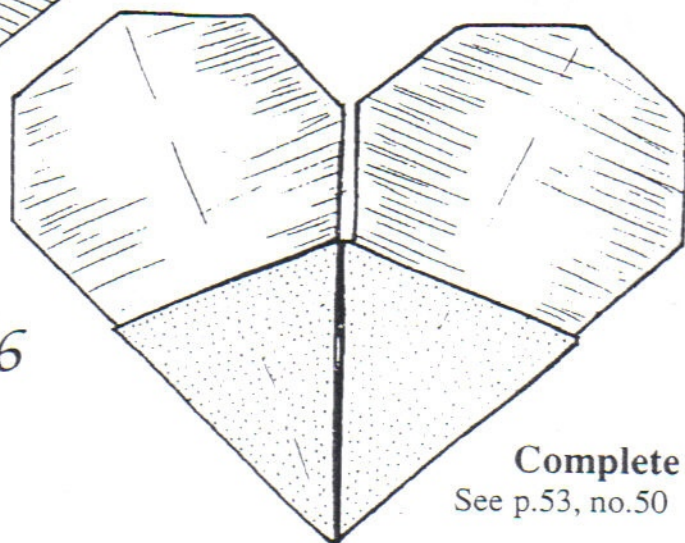

**Complete**  
See p.53, no.50

# A Better Half

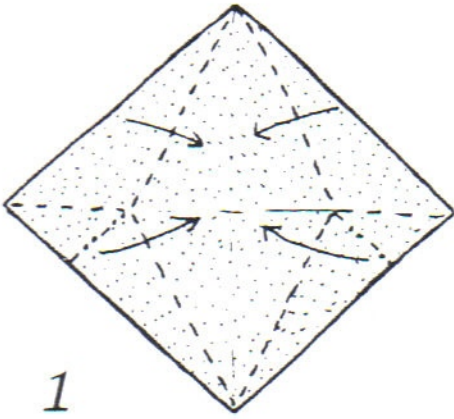

1

Color side up  
or use "Duo-colored" Paper.

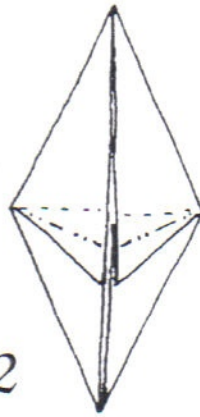

2

FISH BASE.  
Squash the 2 flaps  
and fold the heart  
as in steps 3 to 10  
of HEART RING 2  
(Page 42).

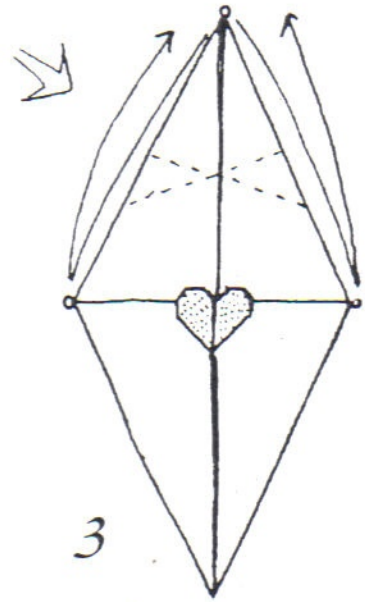

3

Pre-crease.

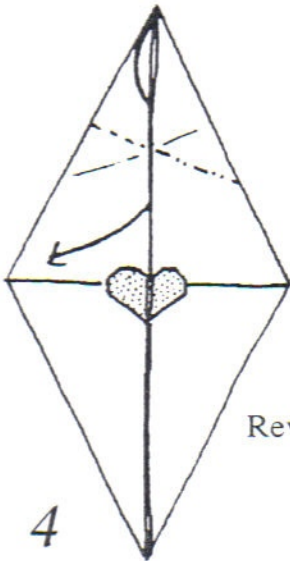

Reverse.

4

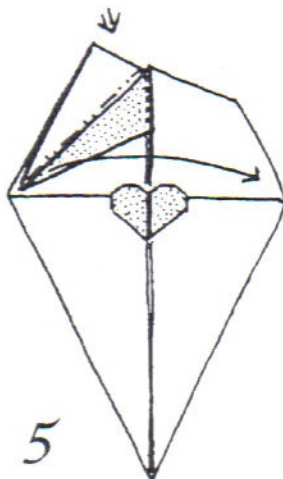

5

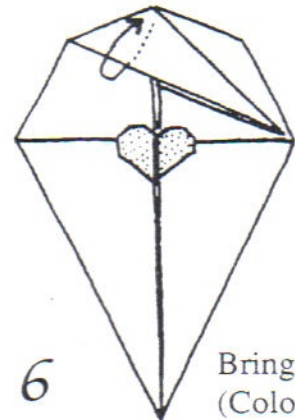

6

Bring out paper.  
(Color changed)

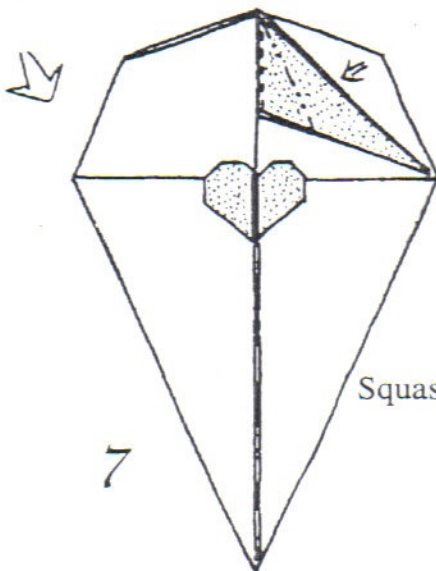

7

Squash.

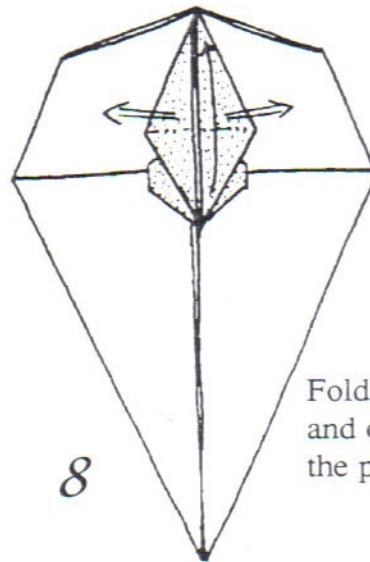

8

Fold the point up  
and open out  
the petal-fold.

# Coaster

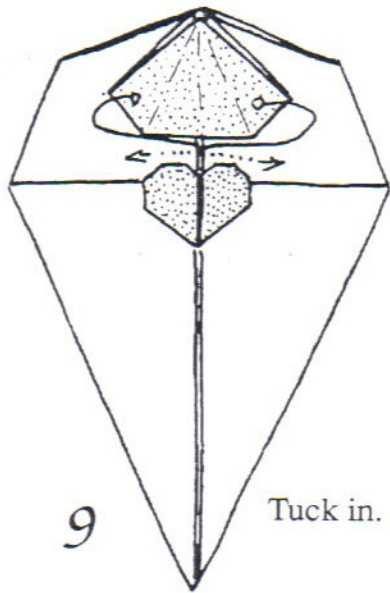

9

Tuck in.

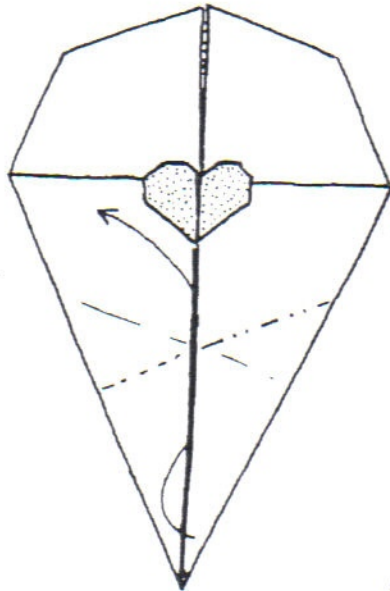

10

Repeat steps 3 to 9 for the bottom half to form a COASTER.

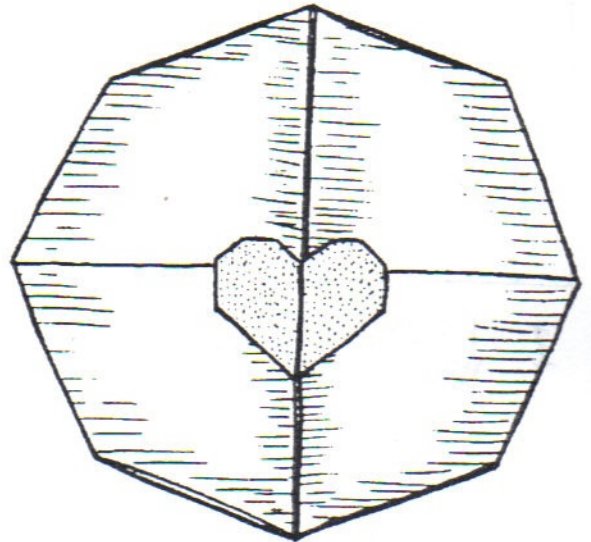

11 Complete  
See p.12, no.40

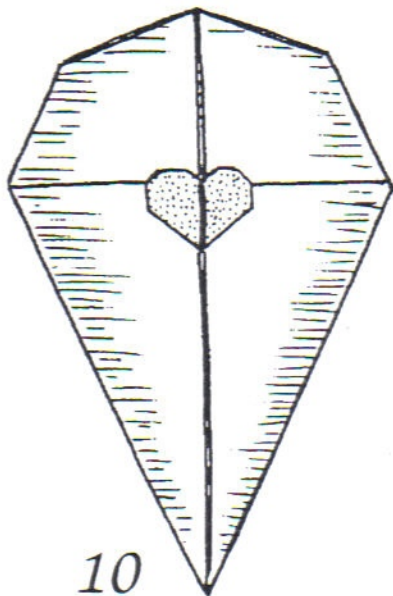

10

Fold one more "half" to complete the HEART.

This is a better half than the previous !

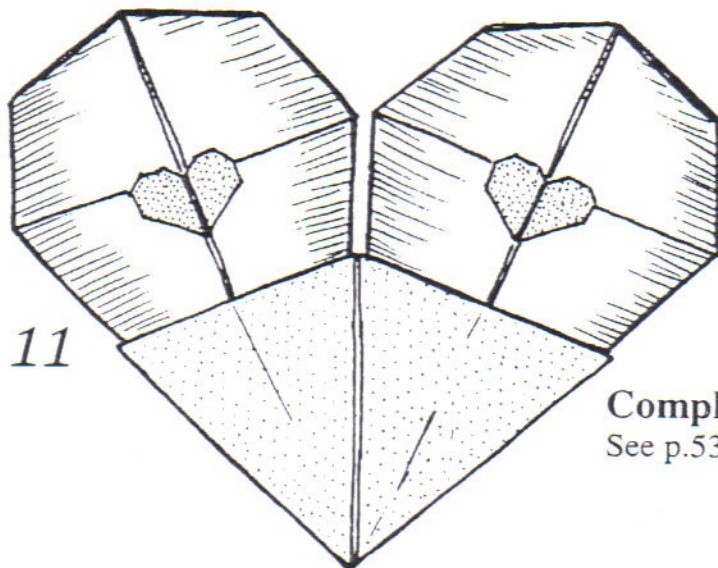

11

Complete  
See p.53, no.52

# Dutch Valentine Card

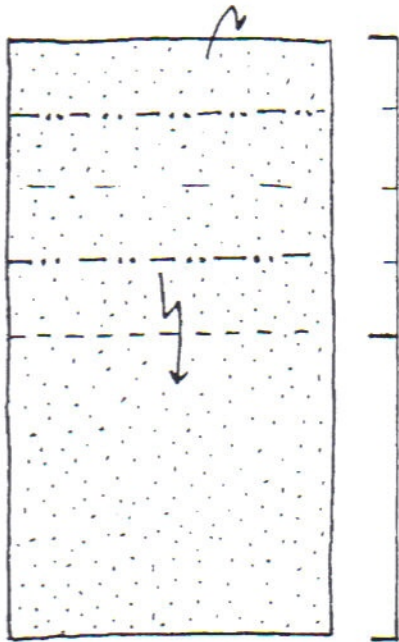

1 1 × 2 rectangle.  
White side up.

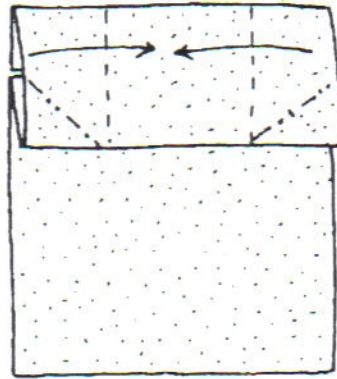

2

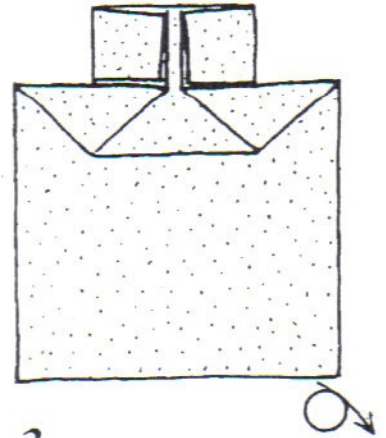

3

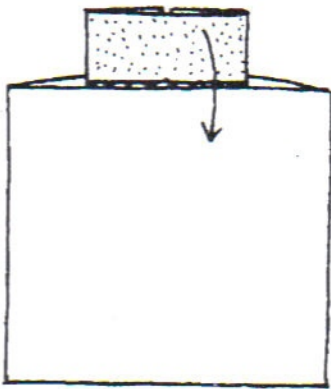

4

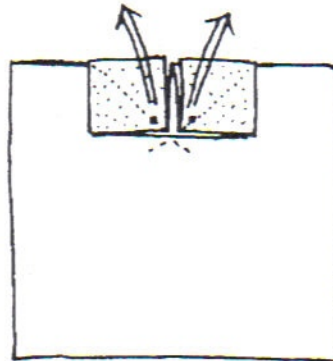

5

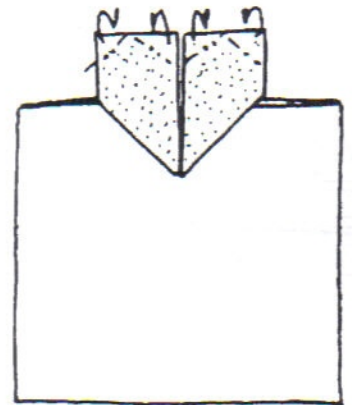

6

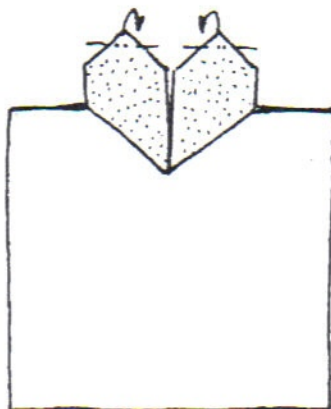

7

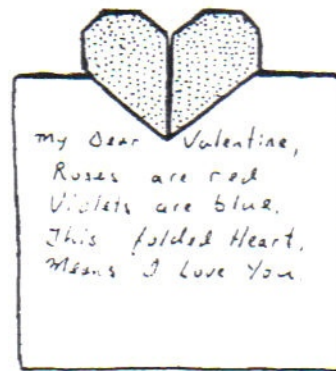

8

**Complete**  
See p.8, no.18

# Box

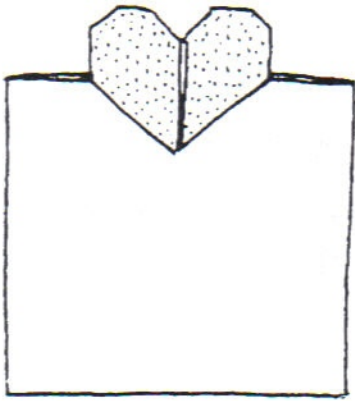

1 VALENTINE CARD  
(Page 50).

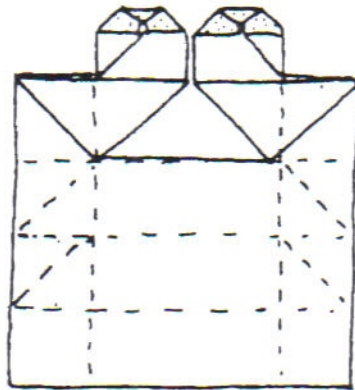

2 Pre-crease.

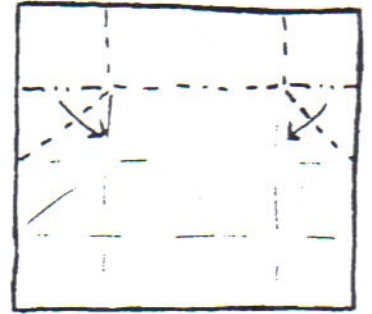

3 Heart omitted.

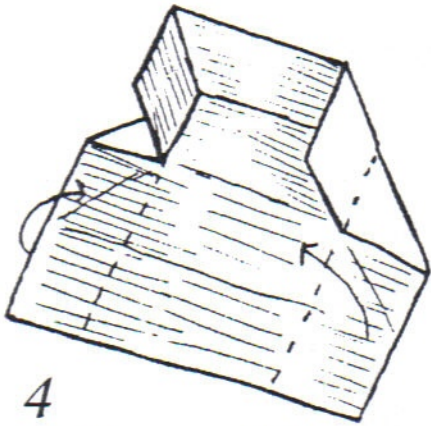

4 Model becomes 3-D.  
Fold up 90°.

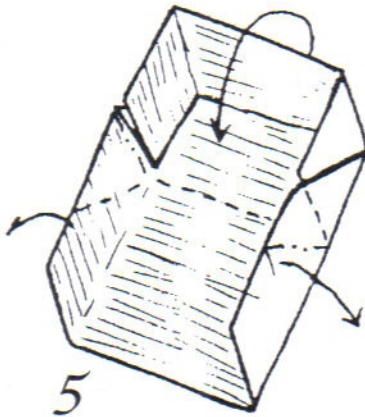

5

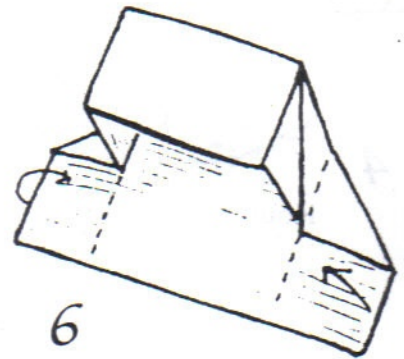

6

Fold up 90°.

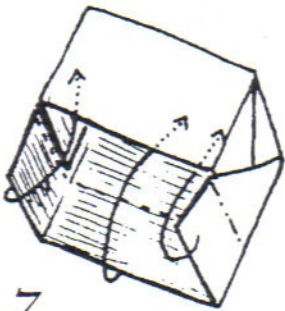

7

Fold edges into box.

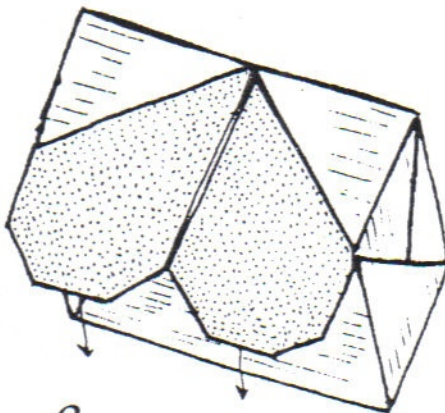

8

Tilt heart to taste.

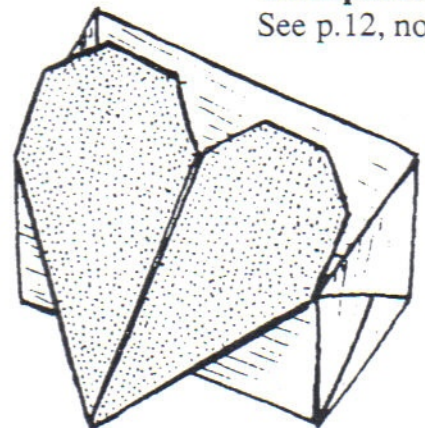

9

**Complete**  
See p.12, no.37

# Love on the Rock

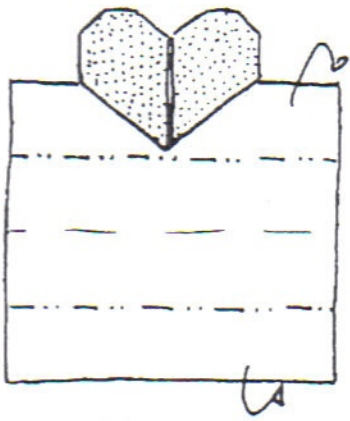

1 VALENTINE CARD  
(Page 50).

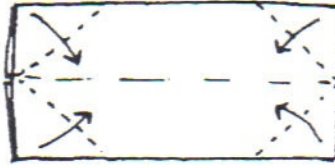

2

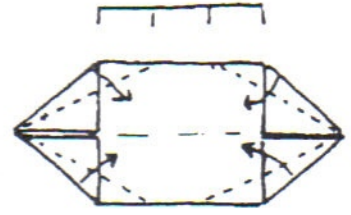

3

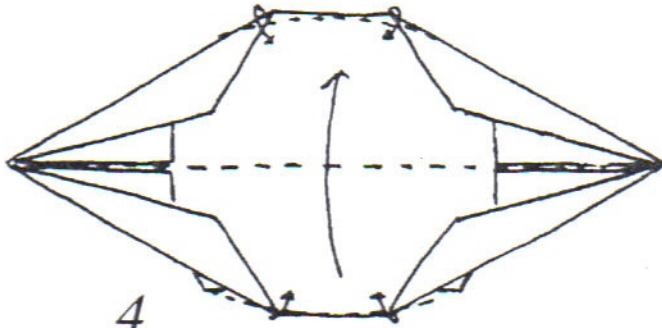

4

Round off the edges.

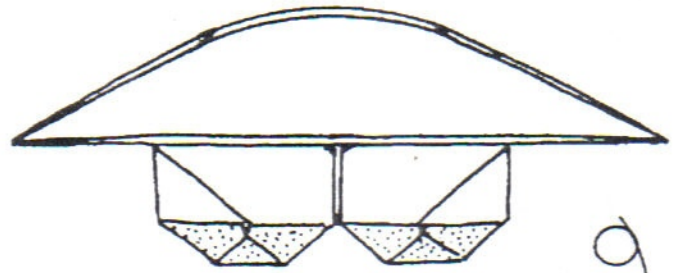

5

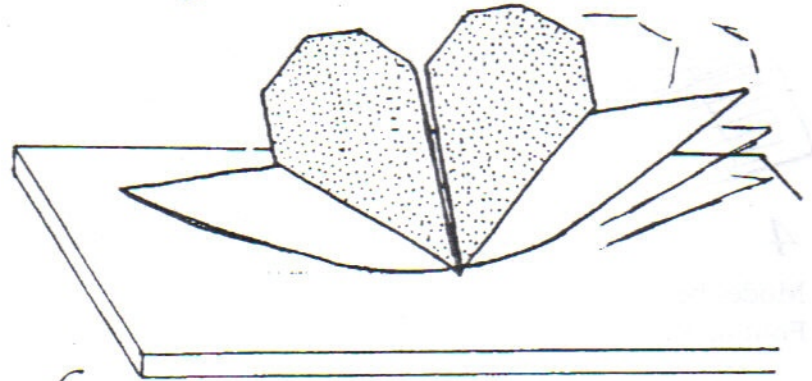

6

**Complete**

See p.10, no.24

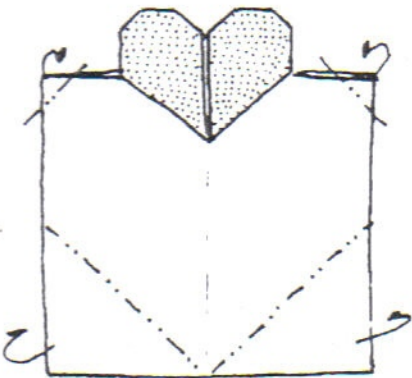

1 VALENTINE CARD

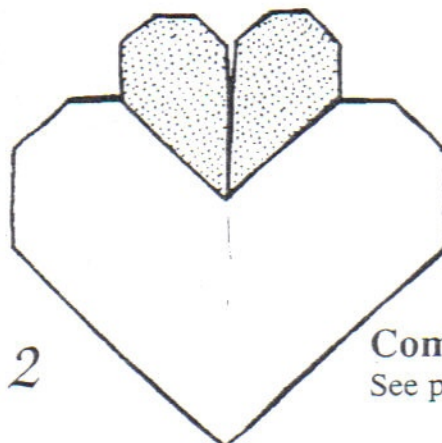

2

**Complete**

See p.8, no.14

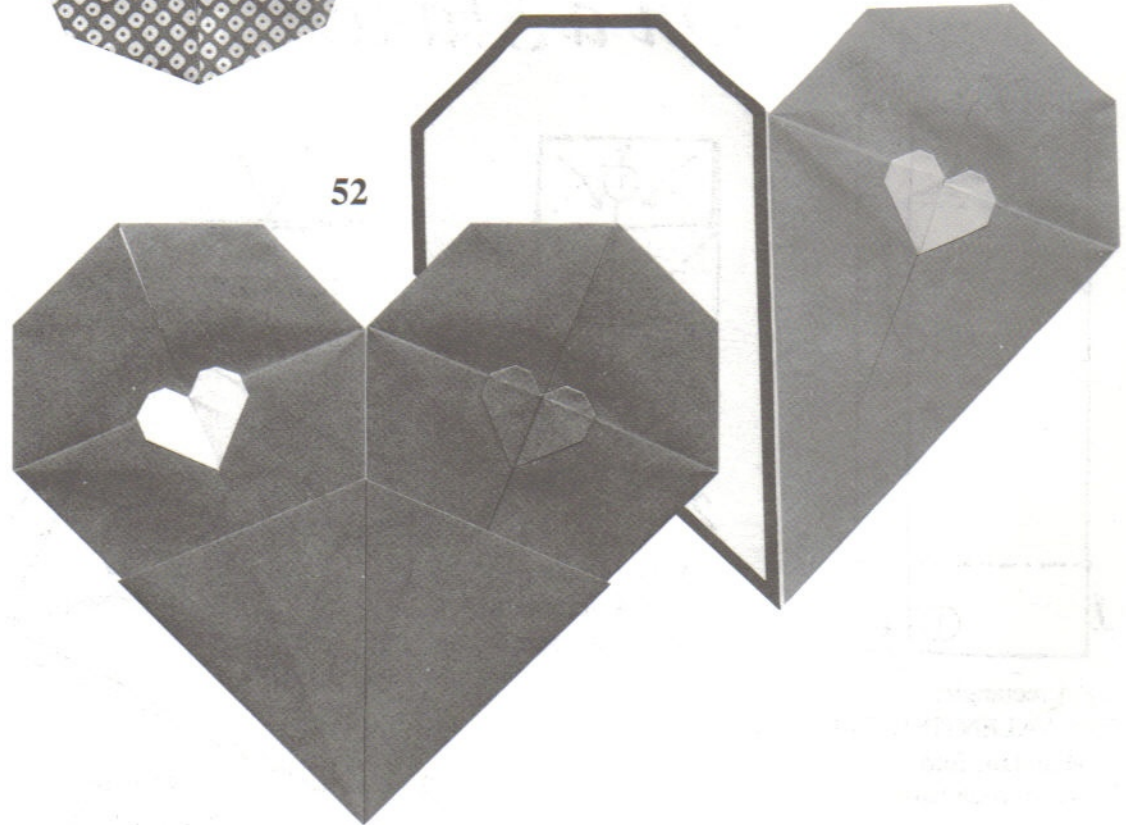
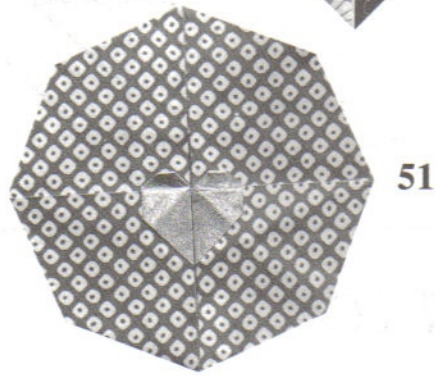
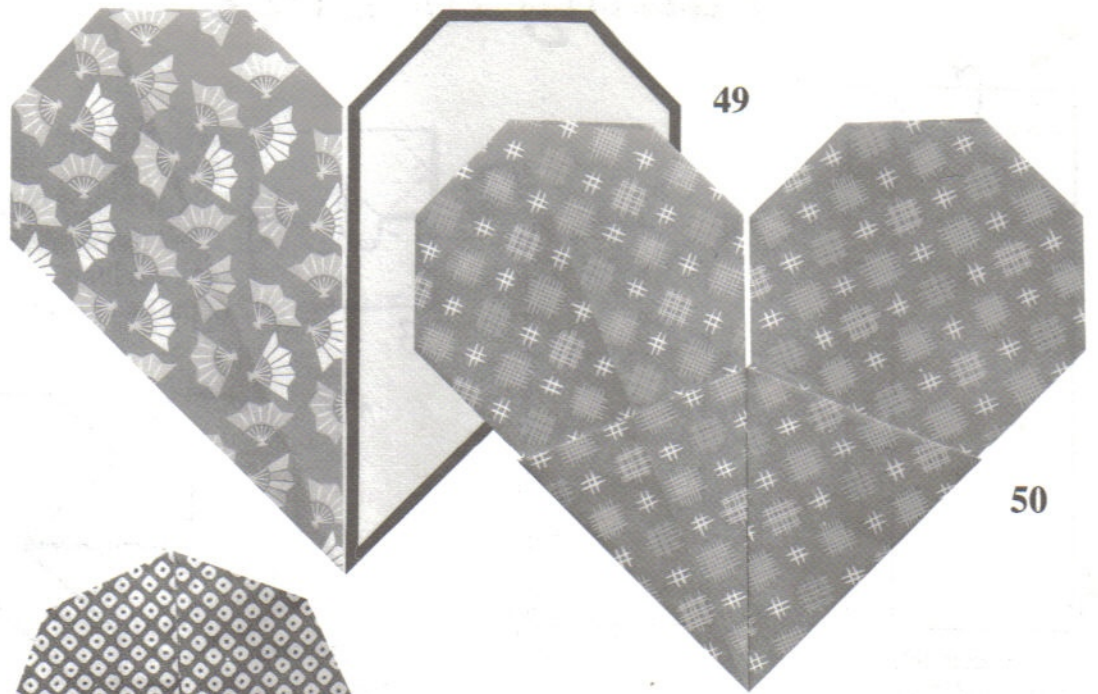

# Falling in Love

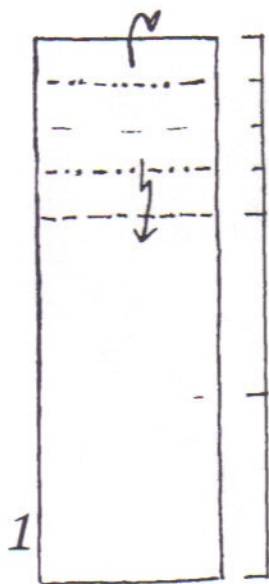

1  
1 × 3 rectangle.  
Fold VALENTINE  
CARD (Page 50).

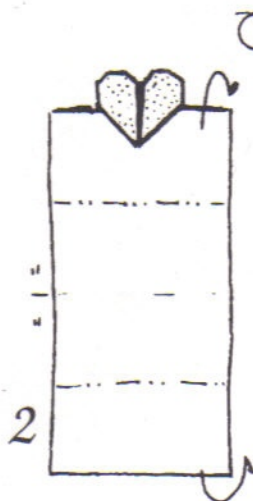

Refer to steps  
9 to 11 of  
"A GIFT OF LOVE"  
(Page 40)  
for the folding  
of the main heart.

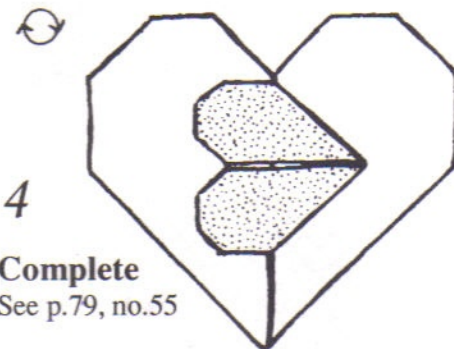

4  
**Complete**  
See p.79, no.55

# On a Stand

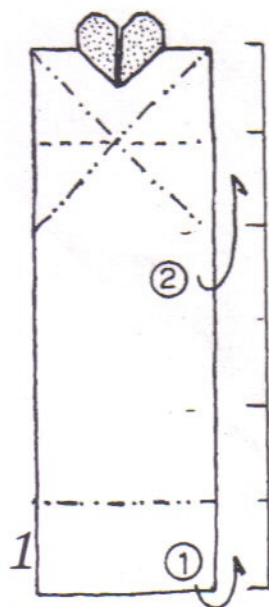

1  
1 × 4 rectangle.  
Fold VALENTINE CARD (Page 50).  
1. Mountain-fold.  
2. Waterbomb base.

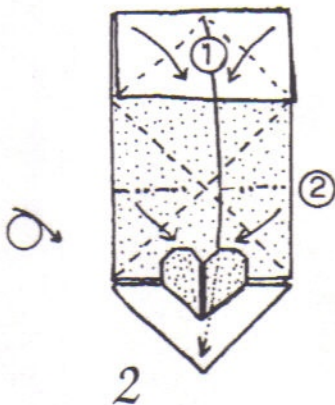

2  
1. Valley-fold.  
2. Fold waterbomb  
base and insert.

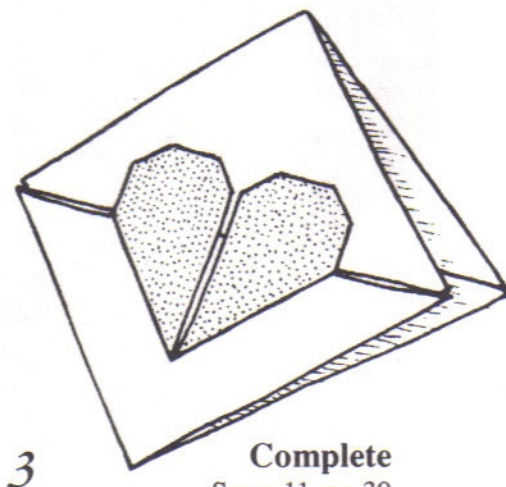

3  
**Complete**  
See p.11, no.30

Fold up the flaps from behind to form the stand.



# 2's Company, 3's a Crowd

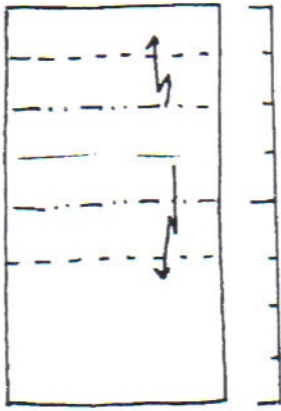

1 1 x 2 rectangle.  
White side up.

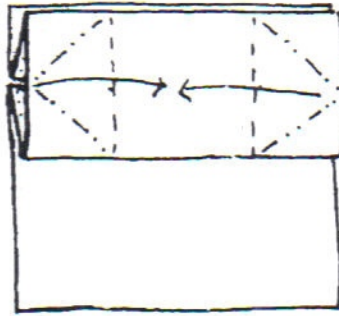

2

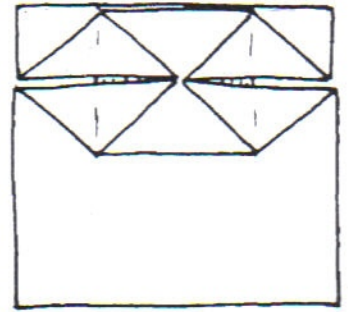

3

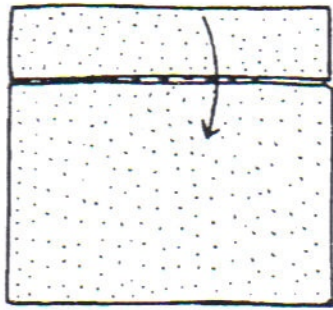

4

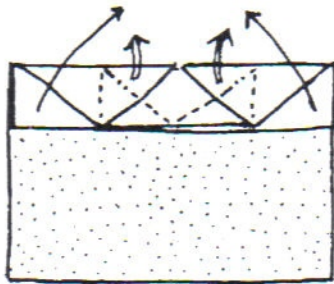

5

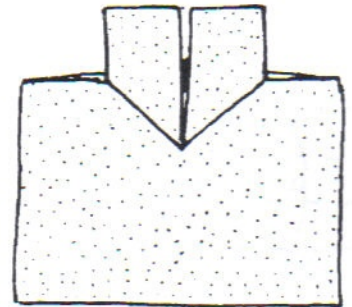

6

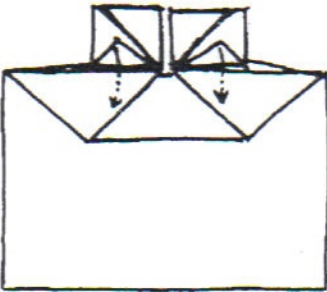

7 Tuck in flaps.

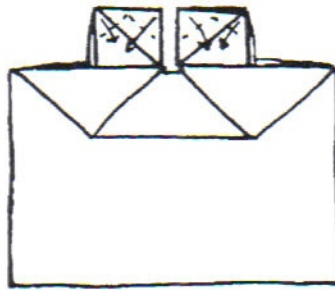

8

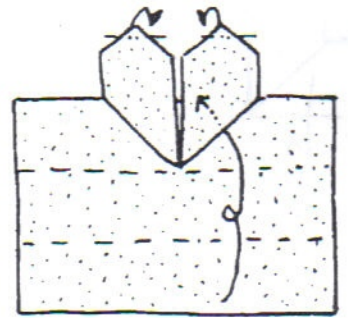

9

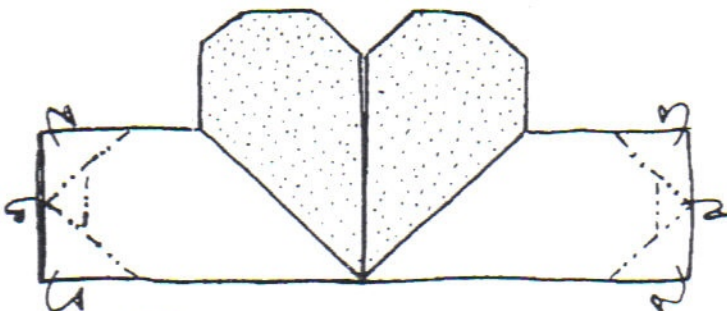

10

Complete  
See p.79, no.53

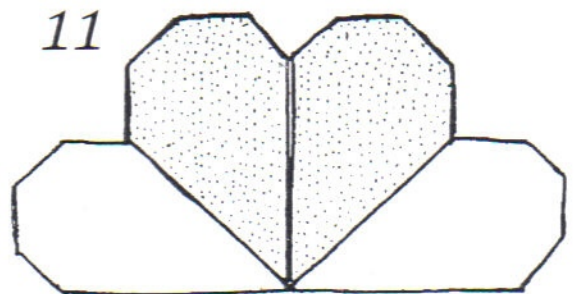

11

# 4's Too Many, 8's an Orgy

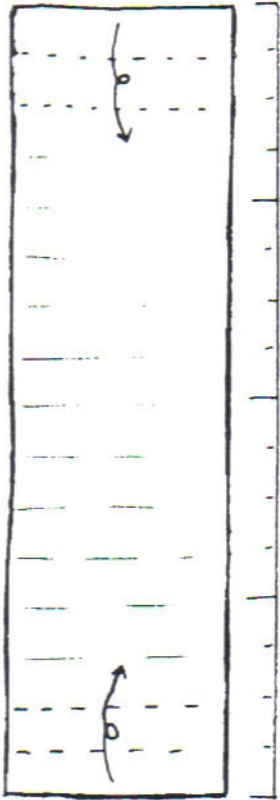

1 1 x 4 rectangle.

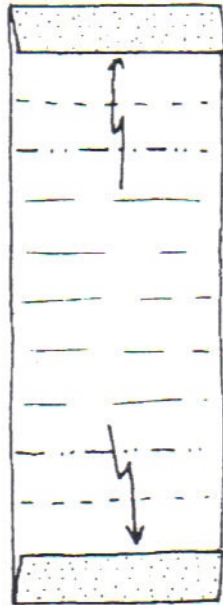

2

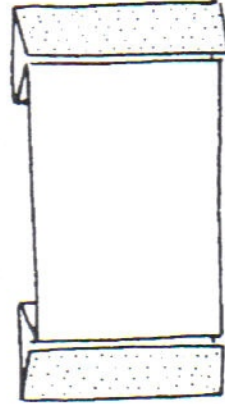

3

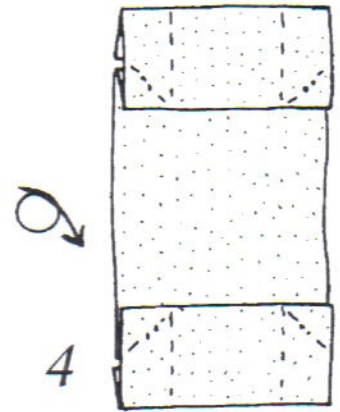

4

Fold as in steps 2 to 5 of VALENTINE CARD. (Top and bottom)(Page 50)

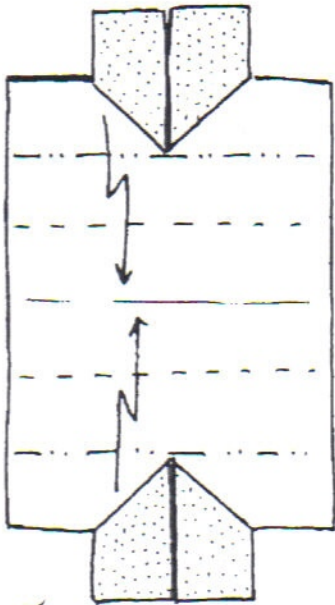

5

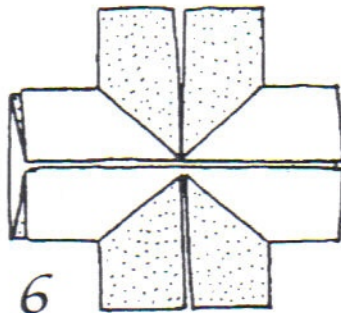

6

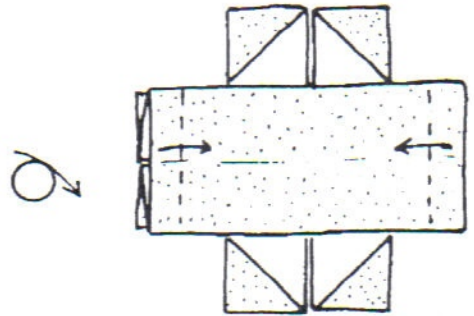

7 Repeat step 8 for the opposite side.

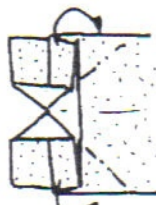

8

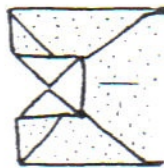

9

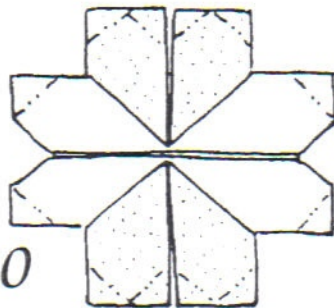

10

Shape all the HEARTS.

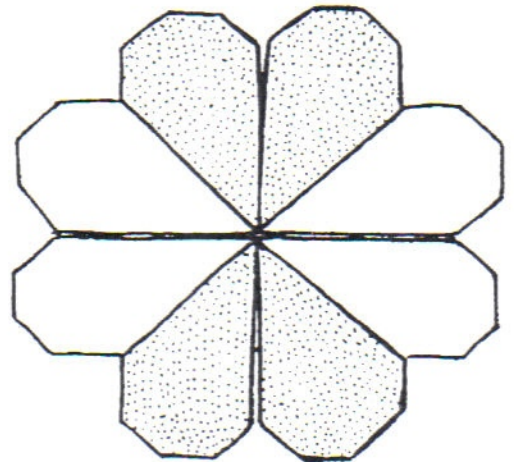

11 Complete  
See p.79, no.56

# Heart Envelope

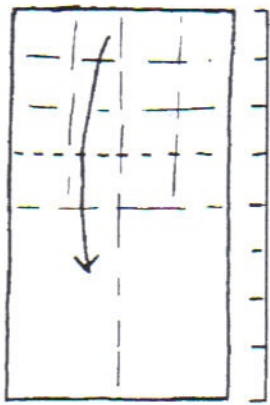

1 1 × 2 rectangle.  
White side up.

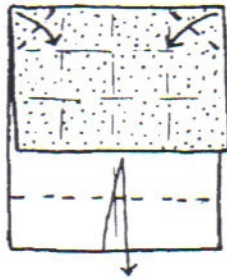

2

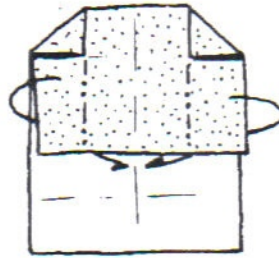

3

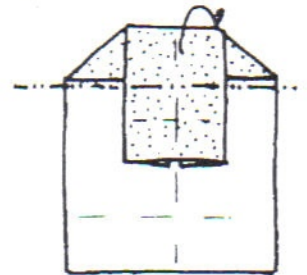

4

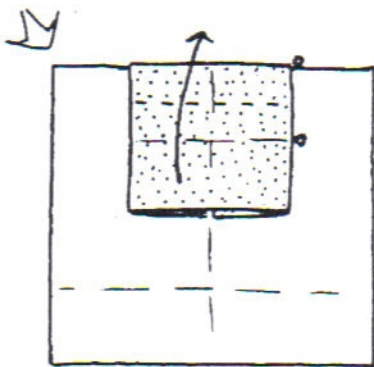

5

NOTE LOCATION POINTS.

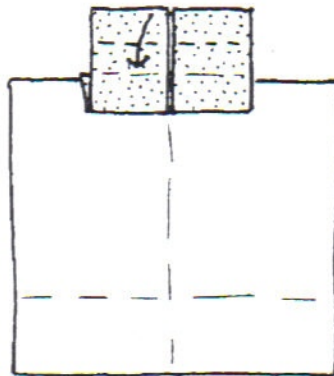

6

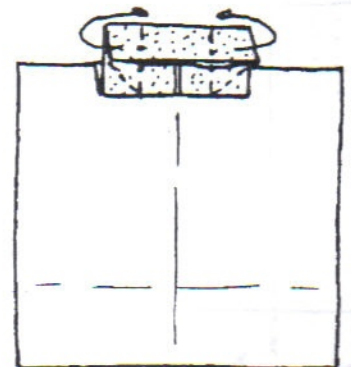

7

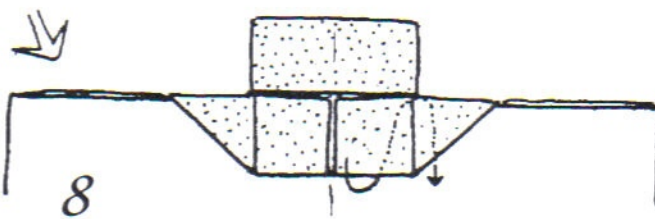

8

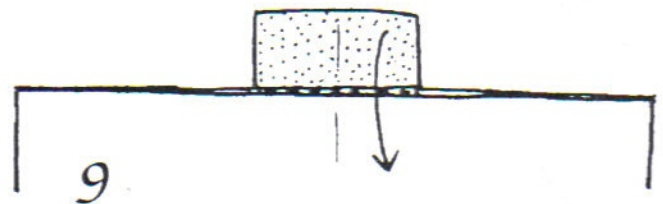

9

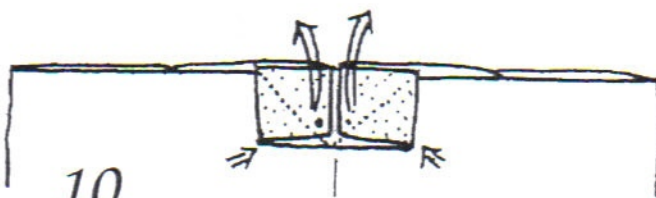

10

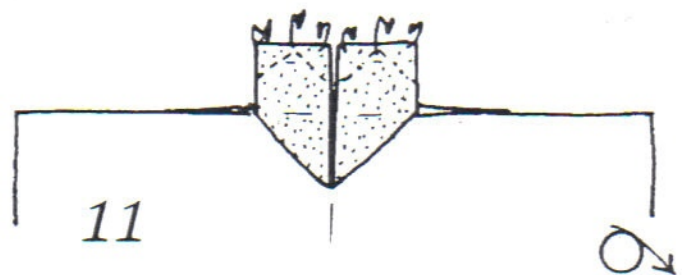

11

Shape the HEARTS.

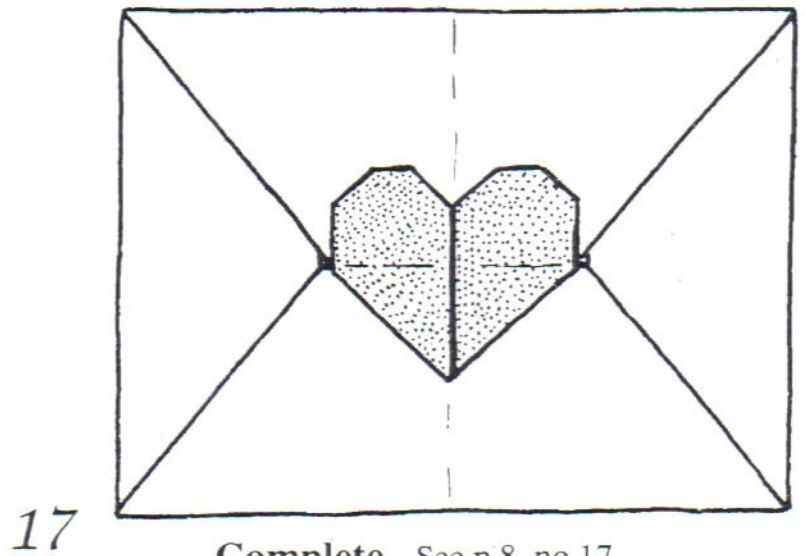
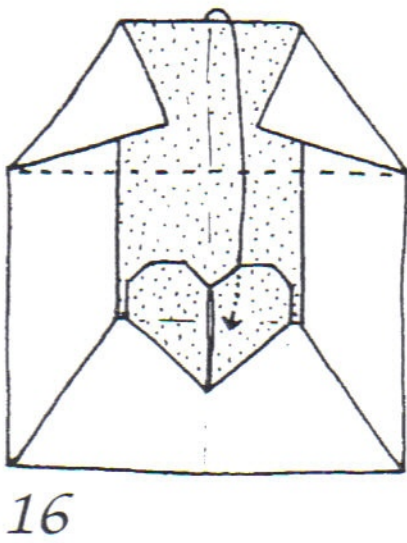
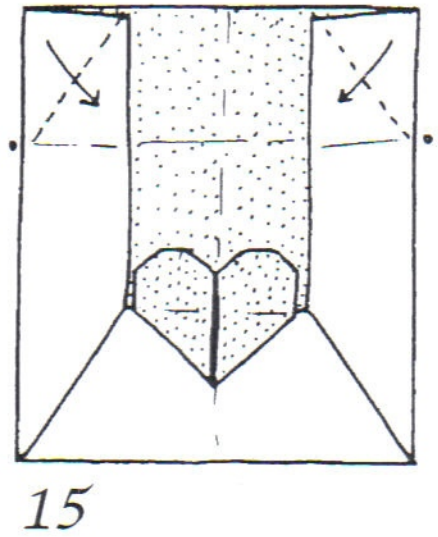
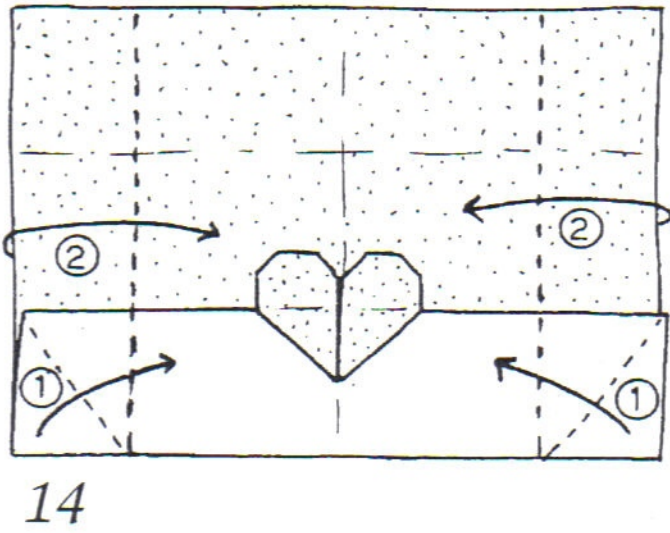
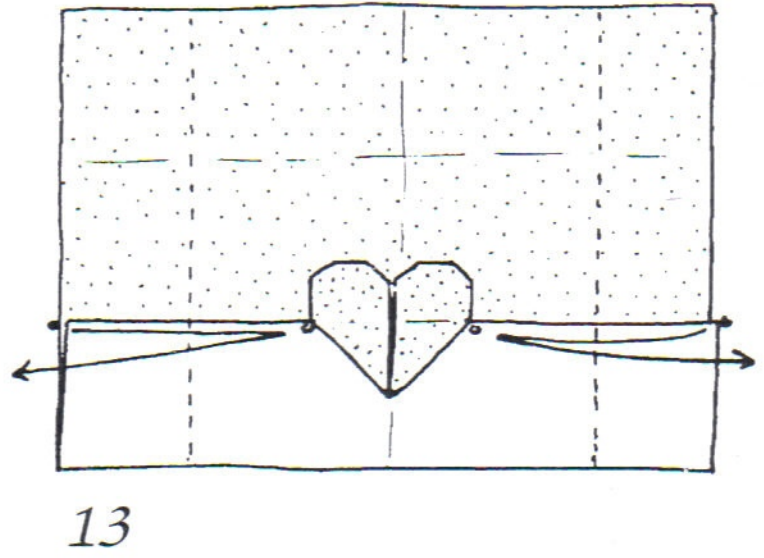
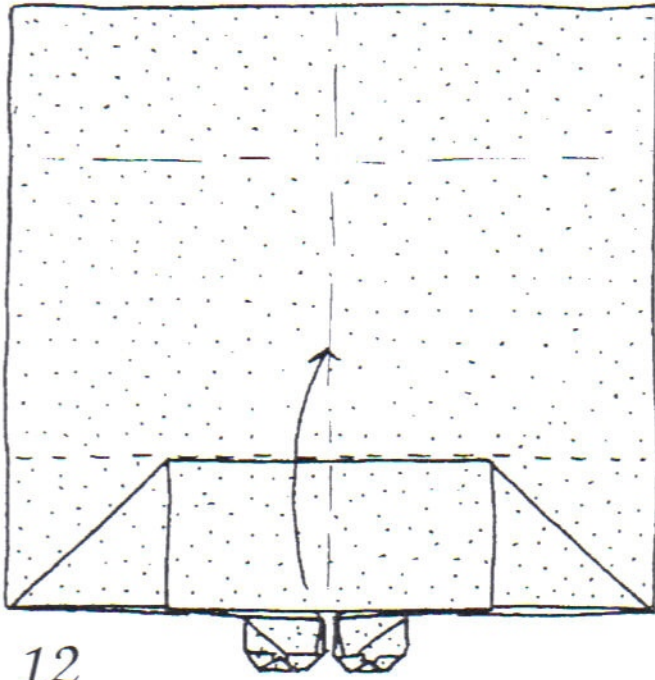

Complete See p.8, no.17

# Sweet Heart

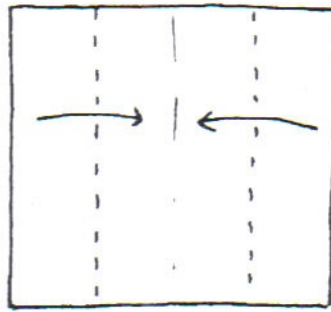
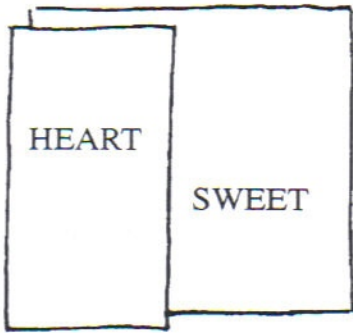

1

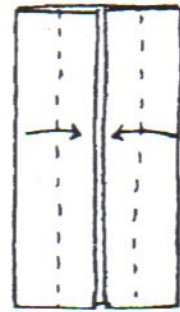

2



3

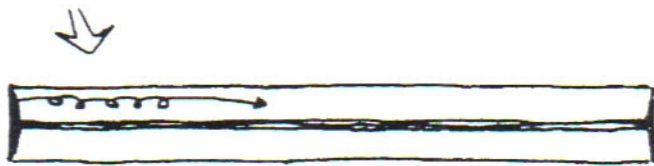

4

Roll to form the "SWEET".



5

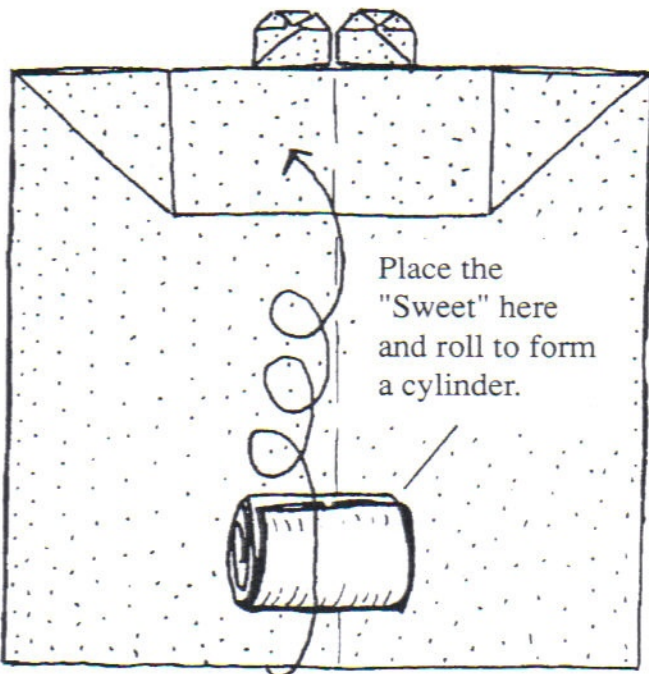

6 Step 12 of HEART ENVELOPE (Page 58).

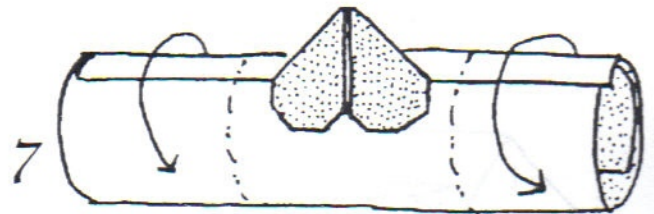

7  
Twist both ends  
to form a  
SWEET HEART.

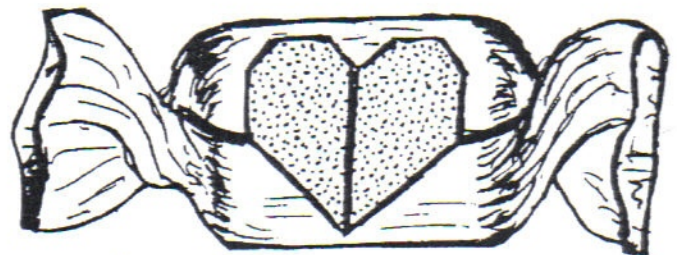

8 Complete See p.12, no.35

Try using real candy  
for this model !

# Love Boxes

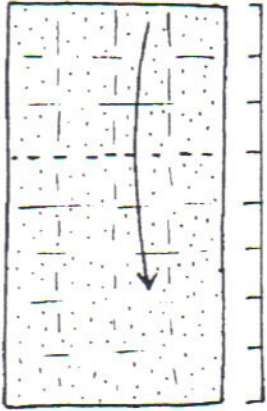

1 1 × 2 rectangle.  
Color side up.

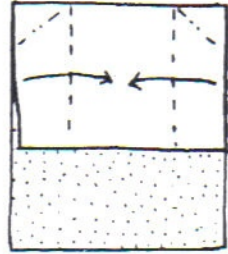

2

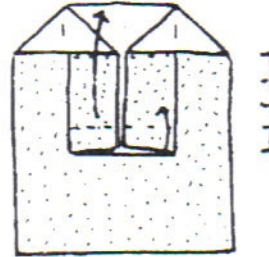

3

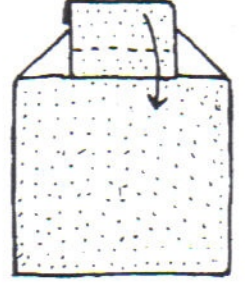

4

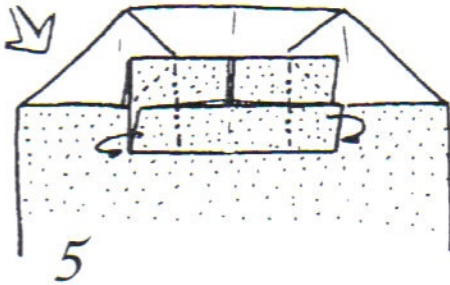

5

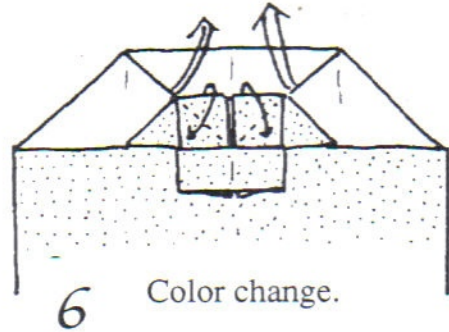

6 Color change.

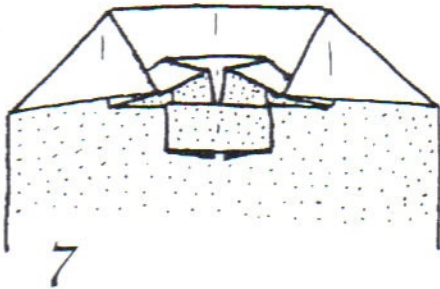

7

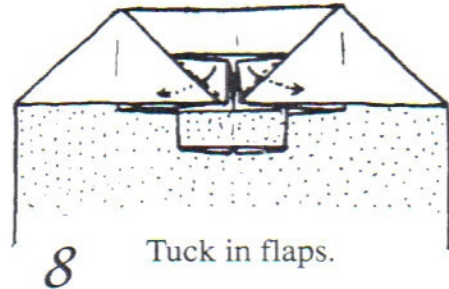

8 Tuck in flaps.

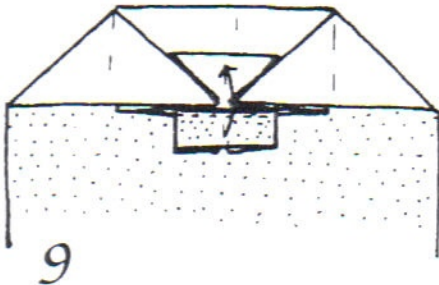

9

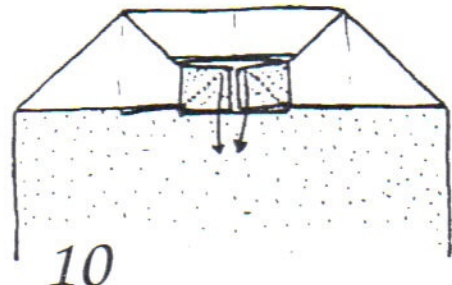

10

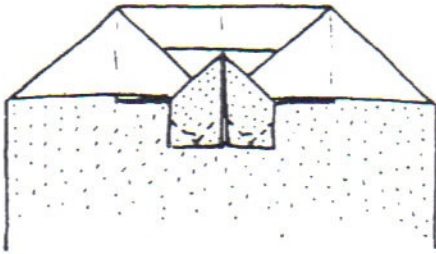

11 Shape the Heart.

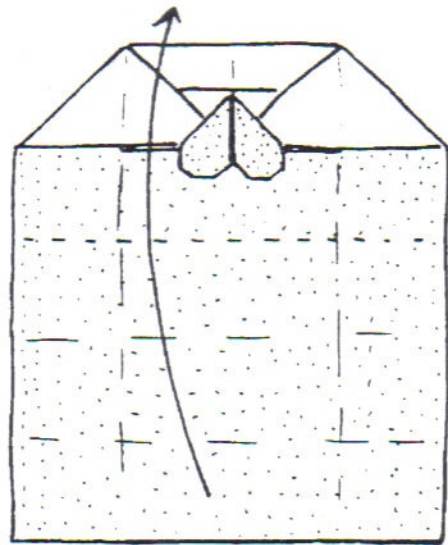

12

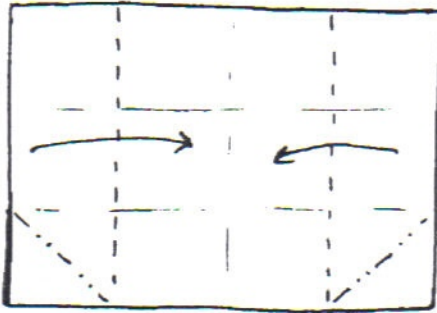

Repeat steps 2 to 11  
for the bottom half.

13

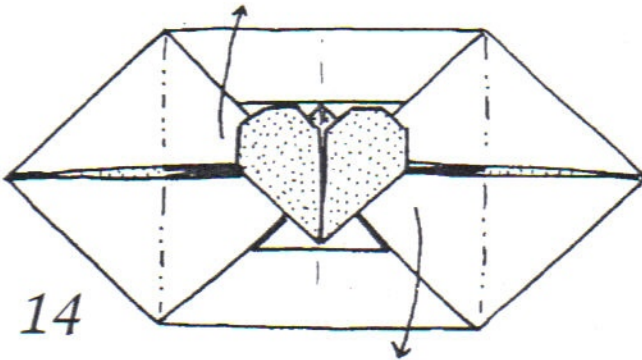

14

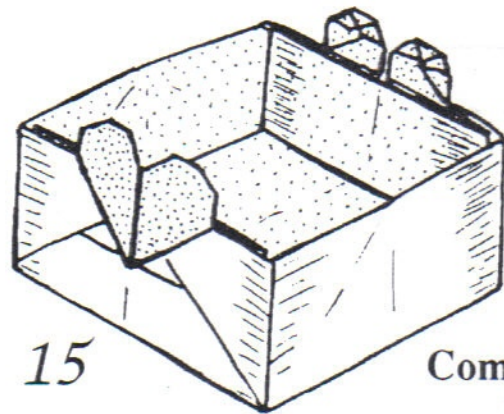

15

Complete

VARIATION

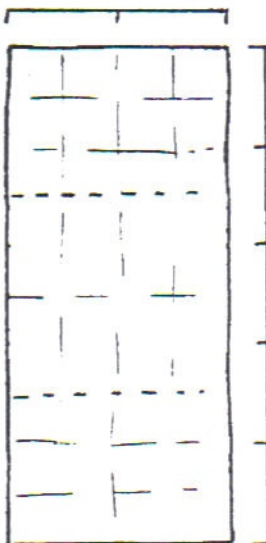

2 × 5 rectangle.

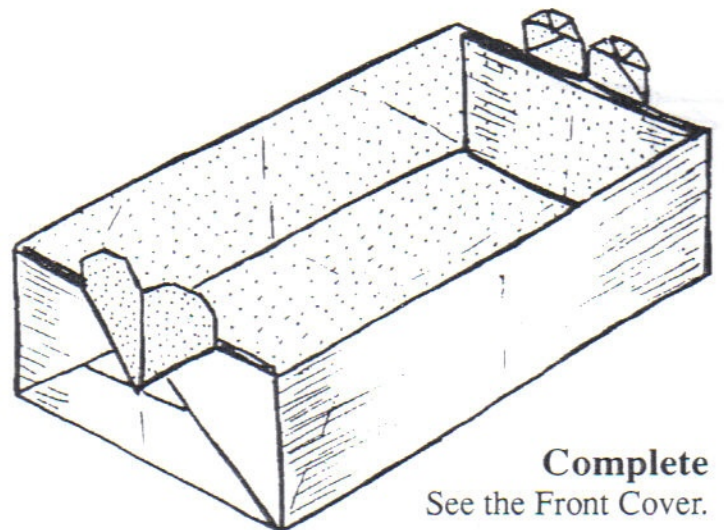

Complete  
See the Front Cover.

# Flowerly Heart

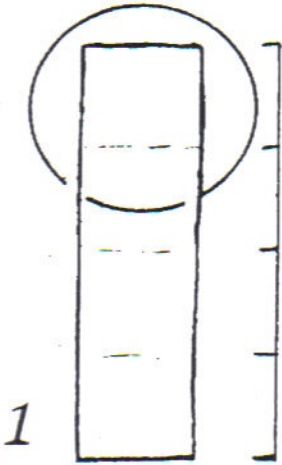

1

1 × 4 rectangle.  
White side up.

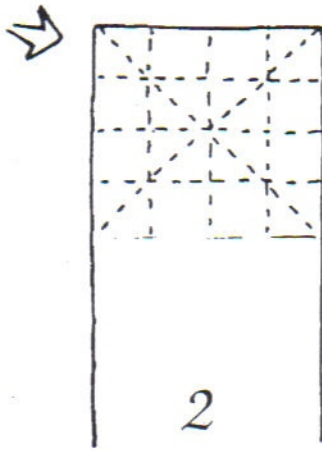

2

Pre-crease.

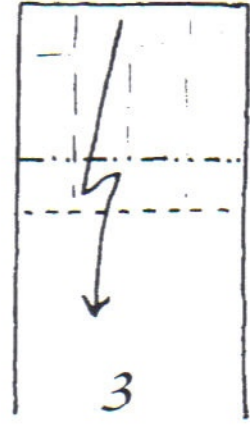

3

Pleat.

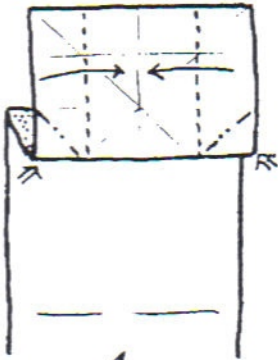

4

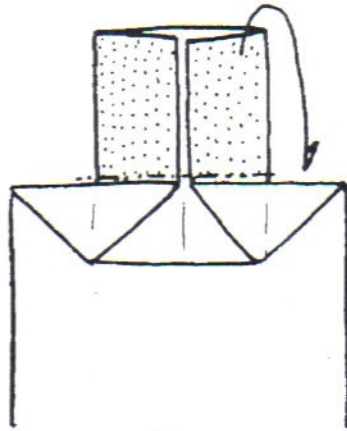

5

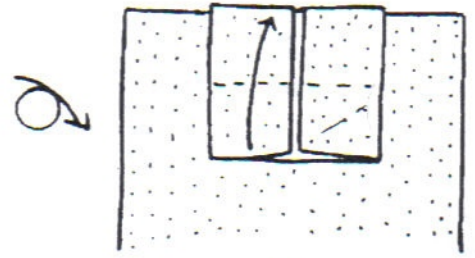

6

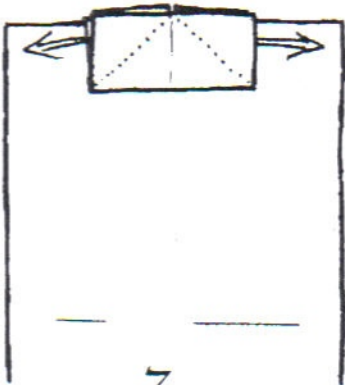

7

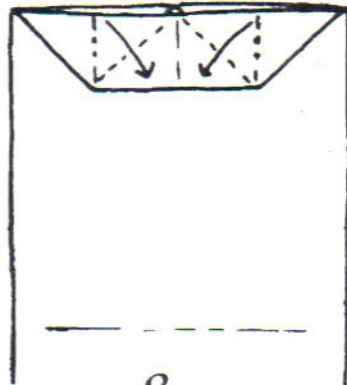

8

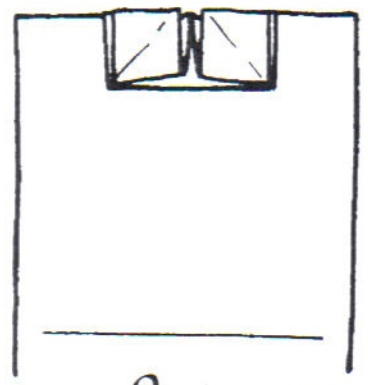

9

Repeat steps 2 to 9 for the bottom.

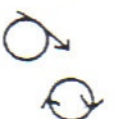



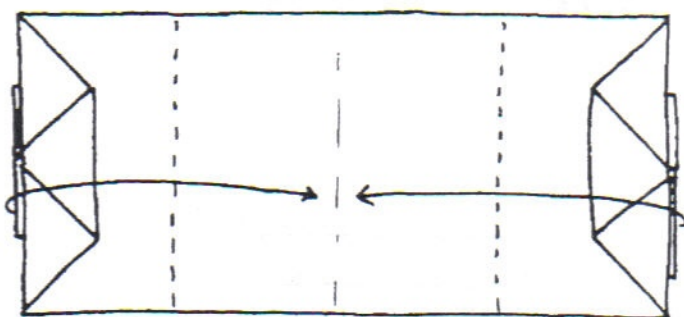

10 Model rotated.

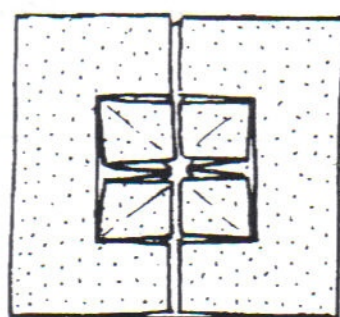

11

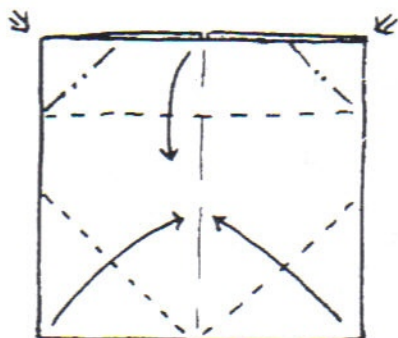

12

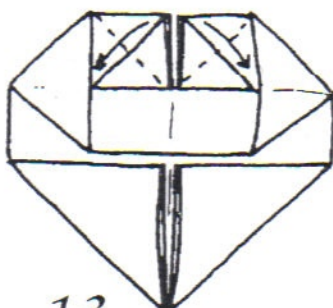

13

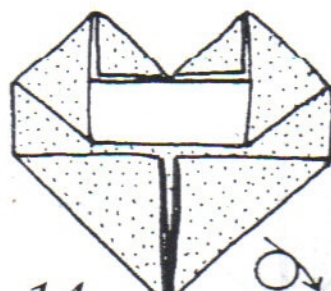

14

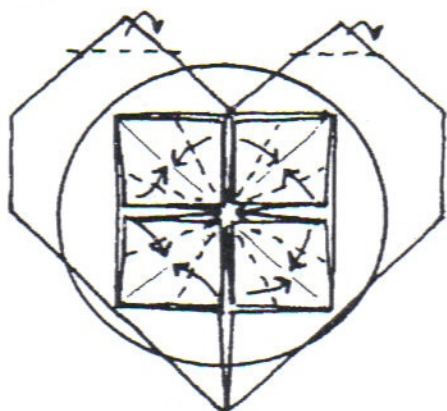

15

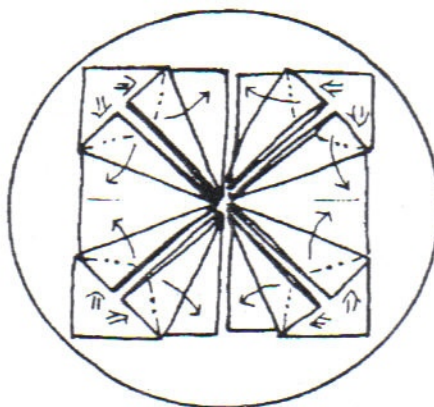

16

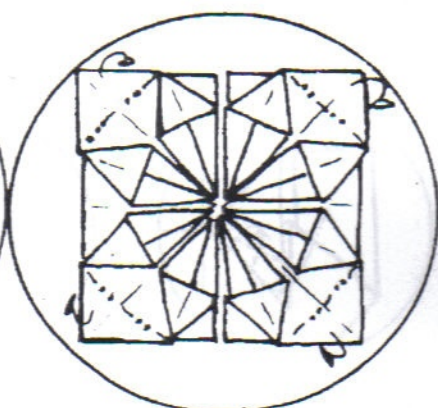

17

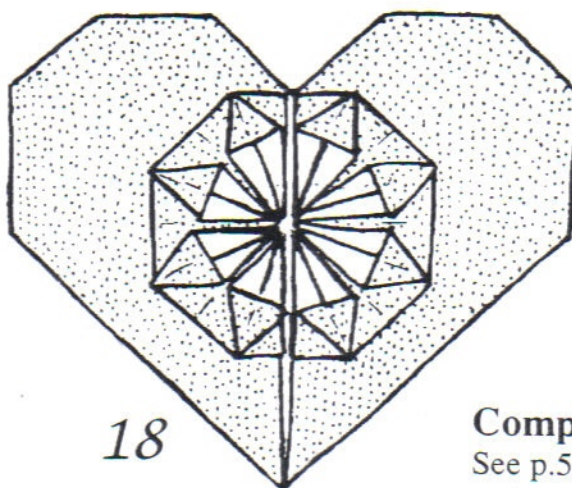

18

Complete  
See p.5, no.3

# Heart ["Fuse" Lock]

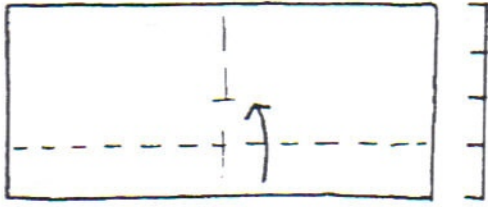

1 2 × 1 rectangle.  
White side up.

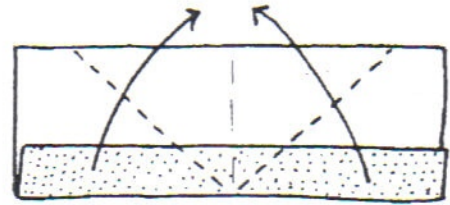

2

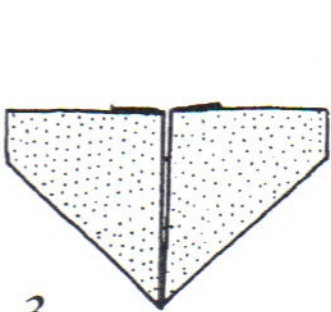

3

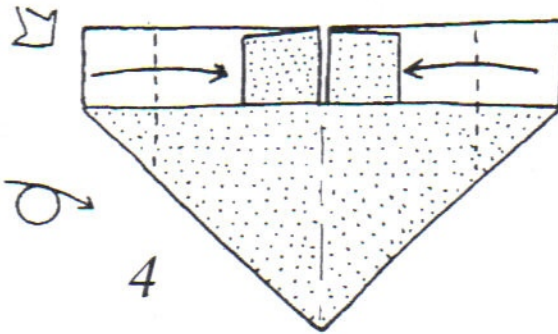

4

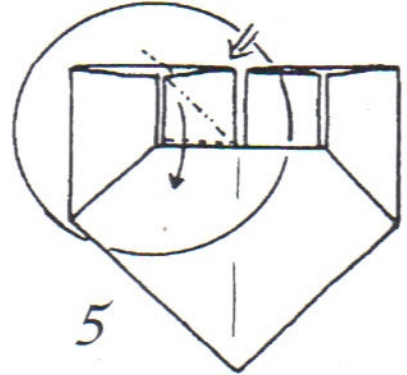

5

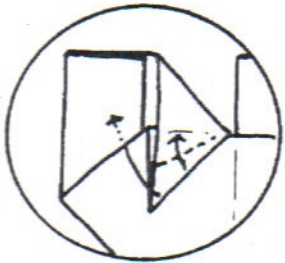

6 Fold up and  
tuck under.

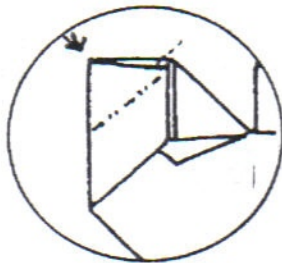

7 Reverse-fold.

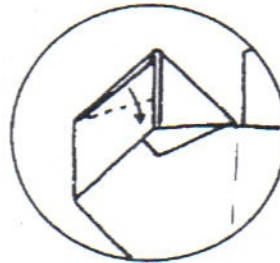

8

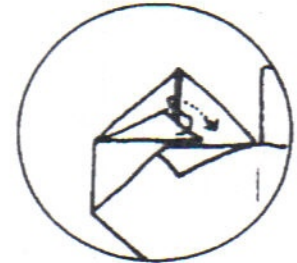

9

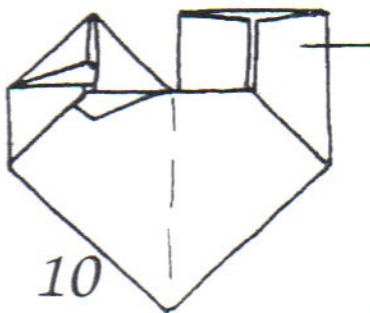

Repeat steps 5 to 9  
for the right side.

10

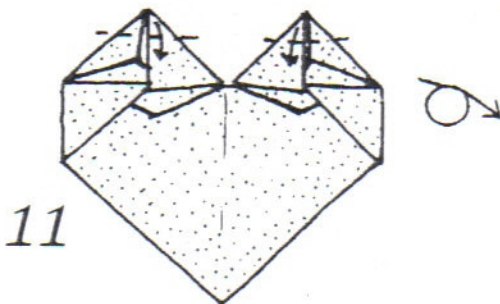

11

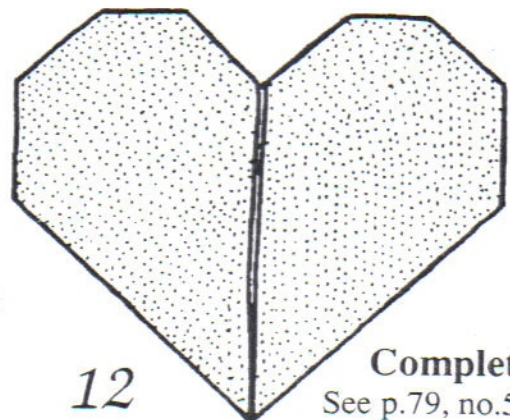

12

**Complete**  
See p.79, no.59

# Spring Heart

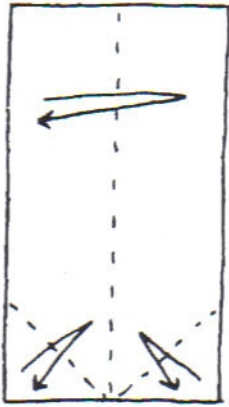

1

1 × 2 rectangle.  
White side up.

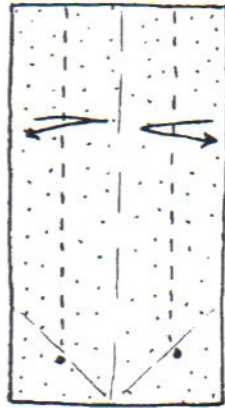

2

Do not crease  
beyond.



3

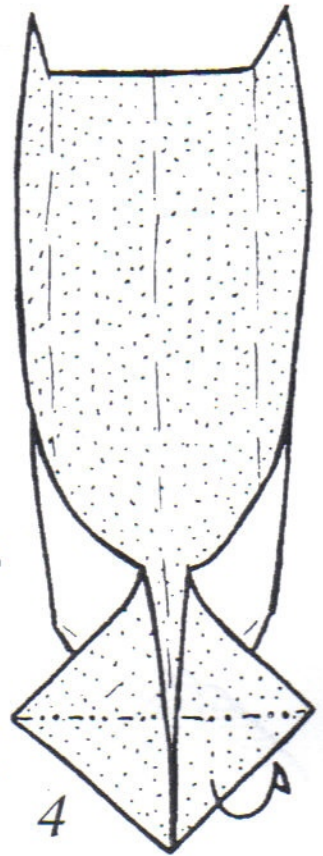

Model not  
flatten.

4

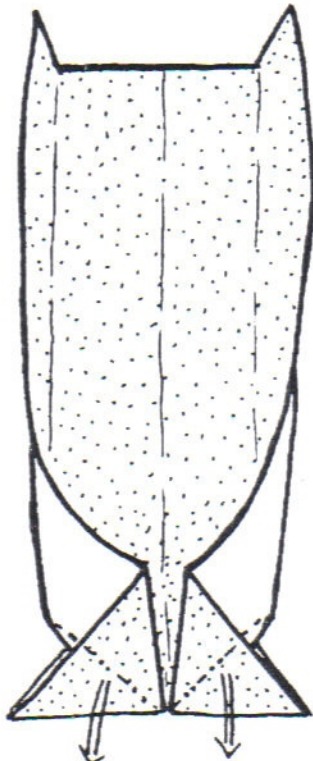

5

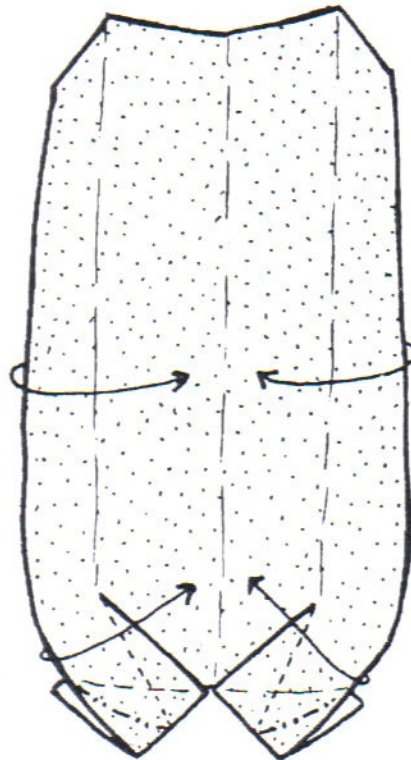

6

Fold the edges  
to the center and  
flatten model.

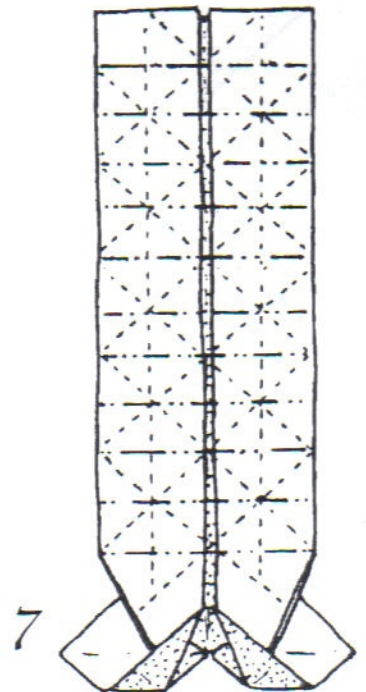

7

Pre-crease.  
All horizontal lines  
are mountain creases.

Box-pleat to form the "Spring".

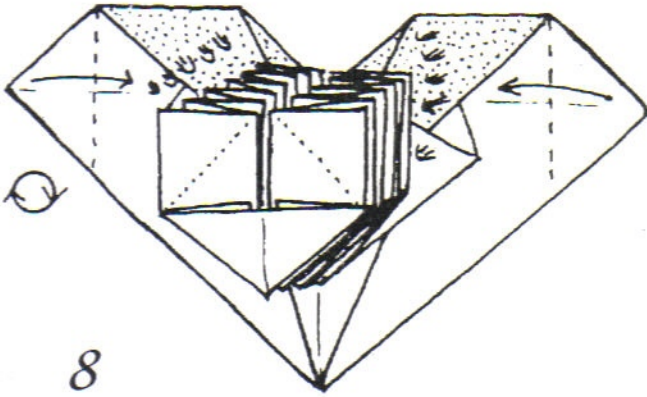

8

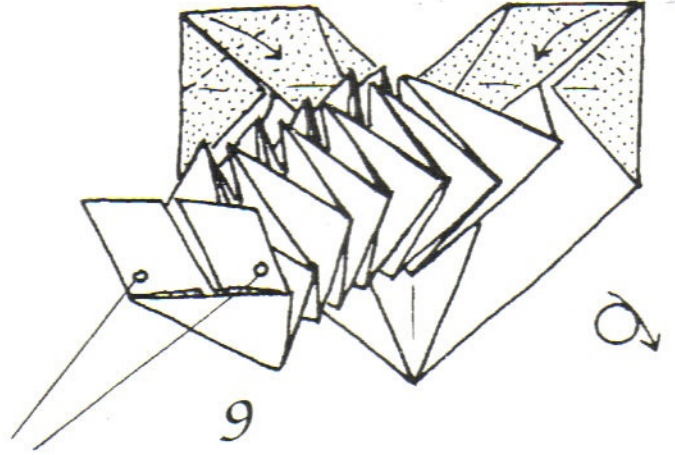

9

Insert into the slot  
of the previous heart.

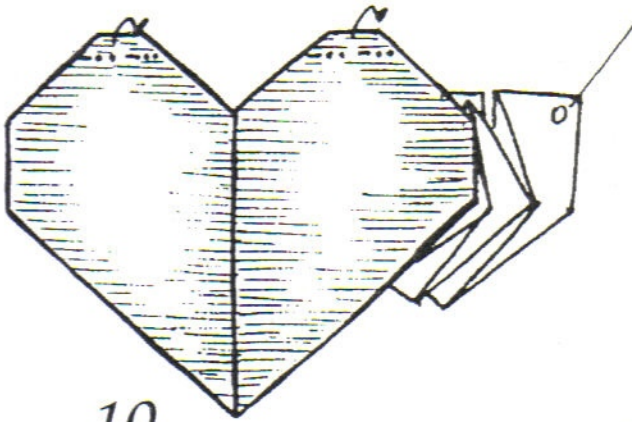

10

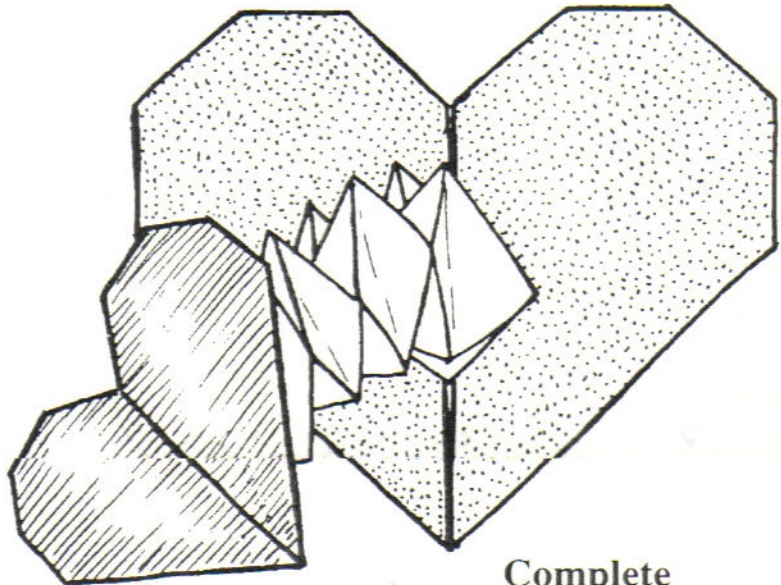

**Complete**  
See p.10, no.26

# Windmill on Heart

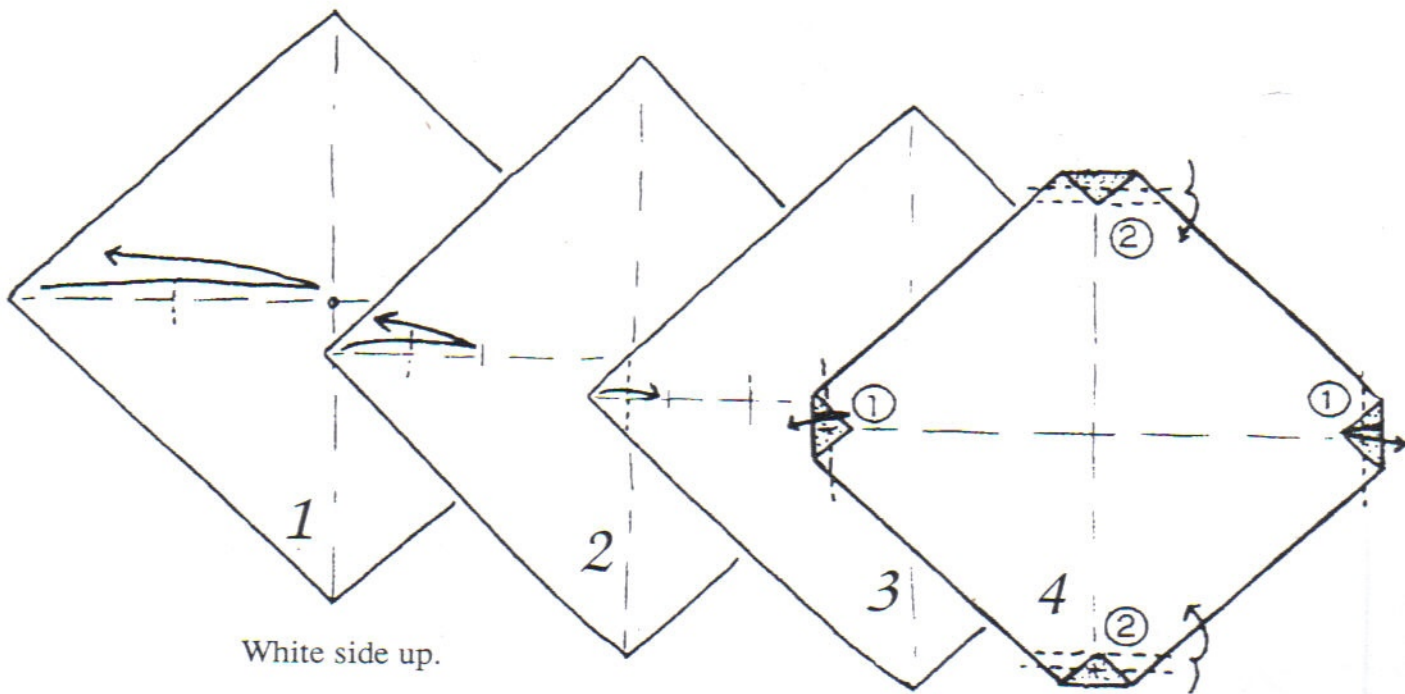

White side up.

1. Crease and unfold.
2. Fold and fold again.

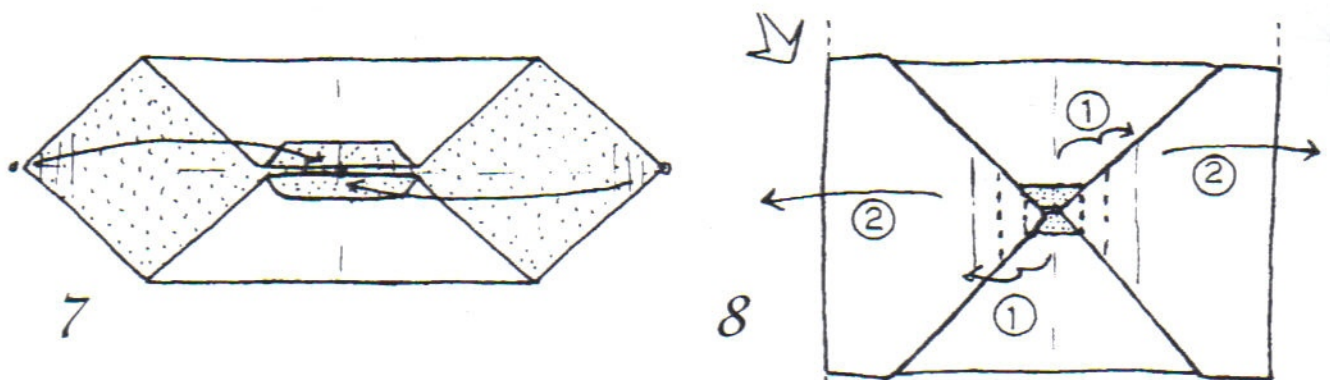
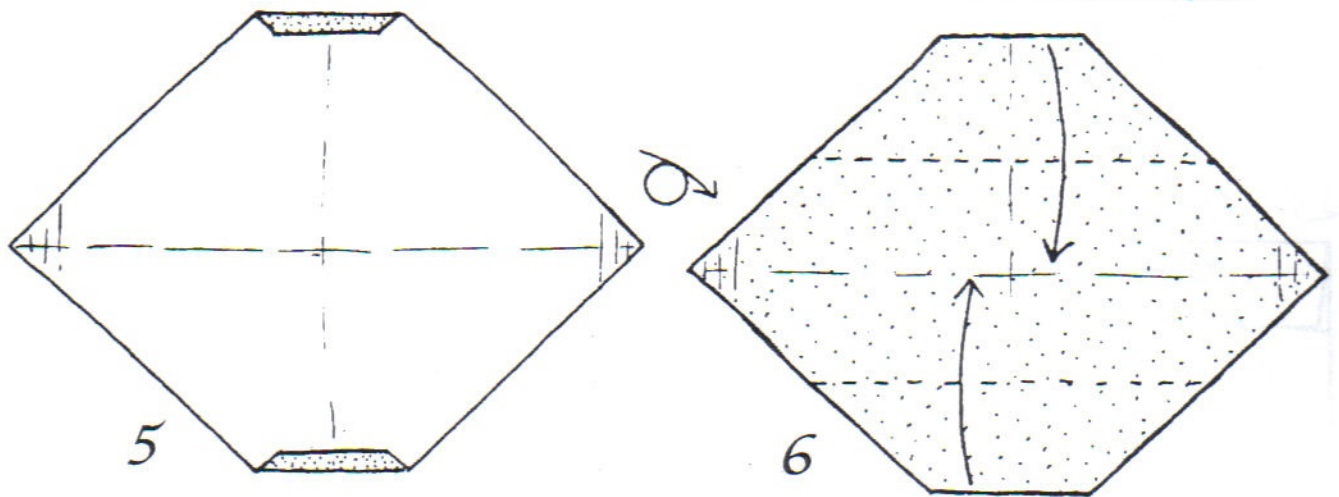

1. Fold and fold again.
2. Unfold.

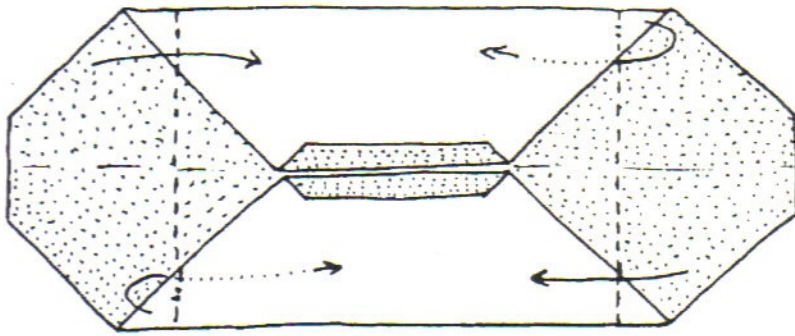

9

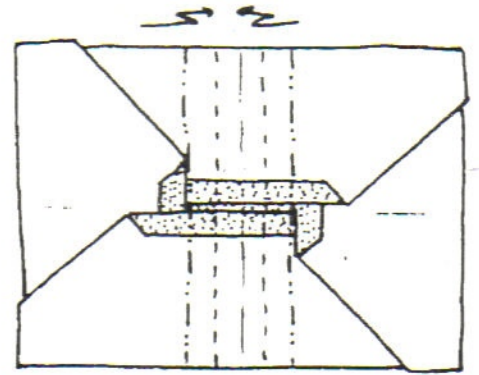

10

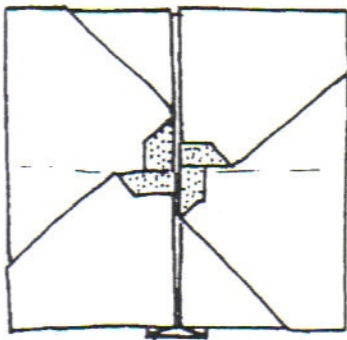

11

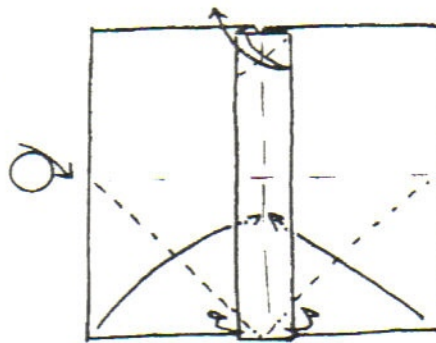

12 Form Heart.

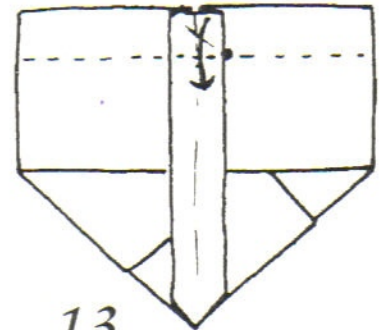

13

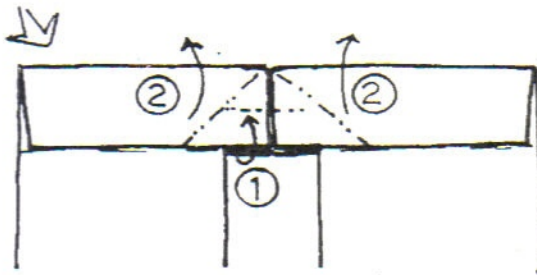

14

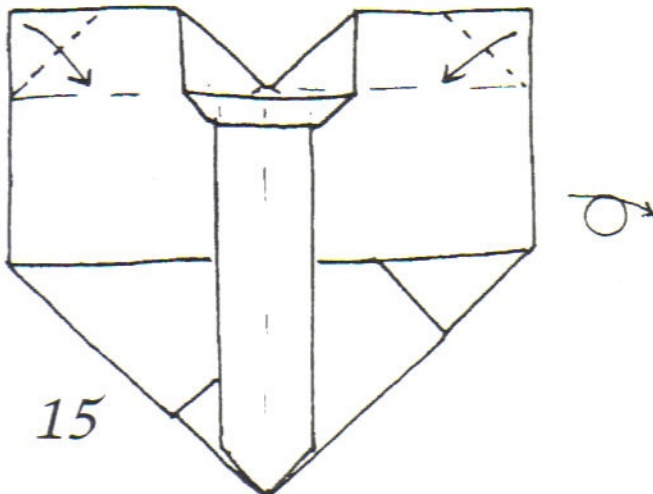

15

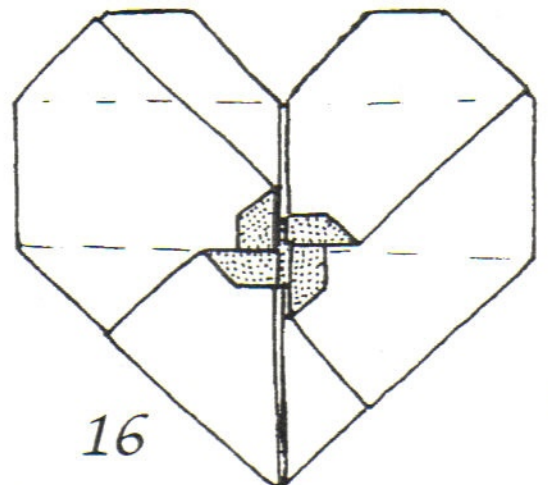

16

**Complete**  
See p.5, no.4

# Baby Love

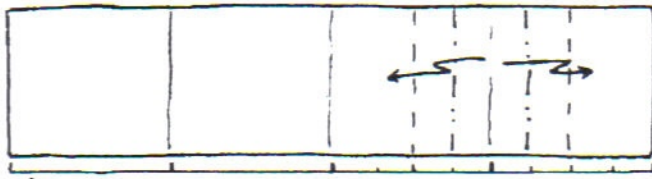

1 4 × 1 rectangle.  
White side up.

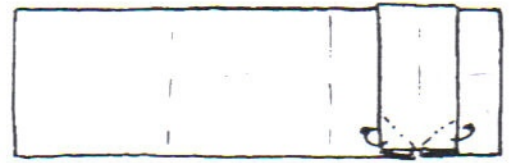

2

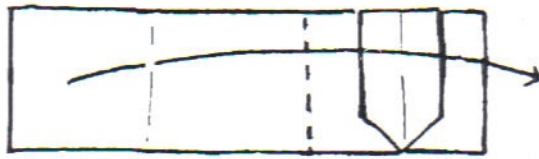

3

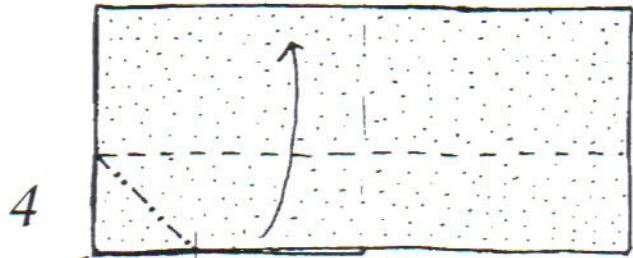

4

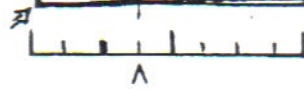

NOTE POSITION OF  
MOUNTAIN-FOLD.

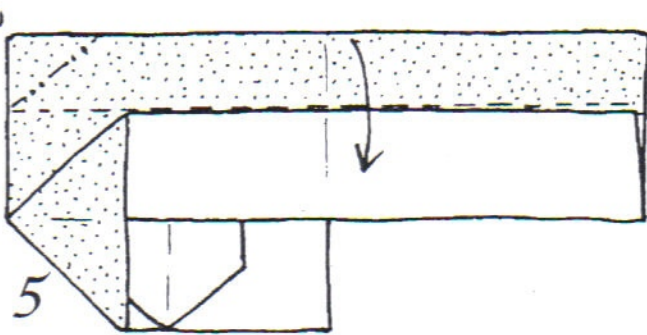

5

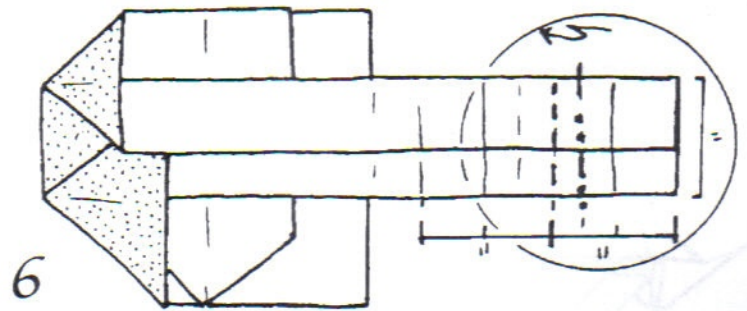

6

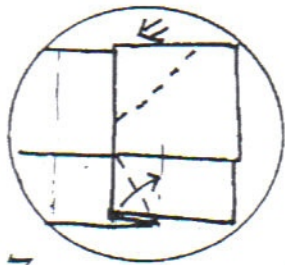

7

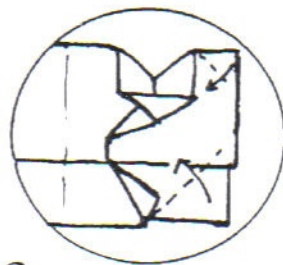

8

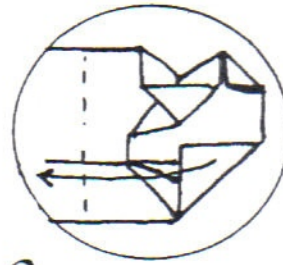

9

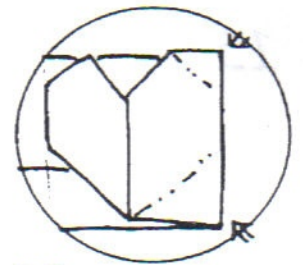

10

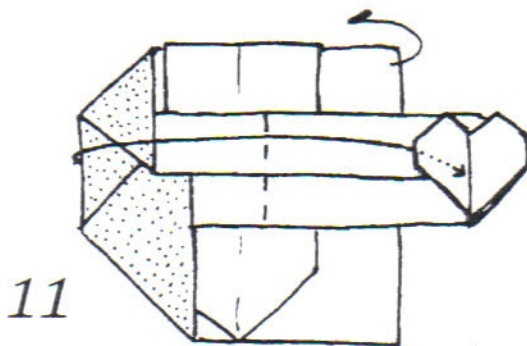

11

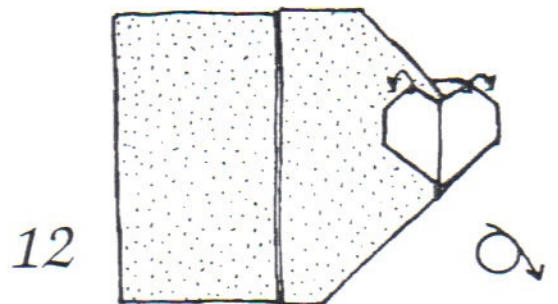

12

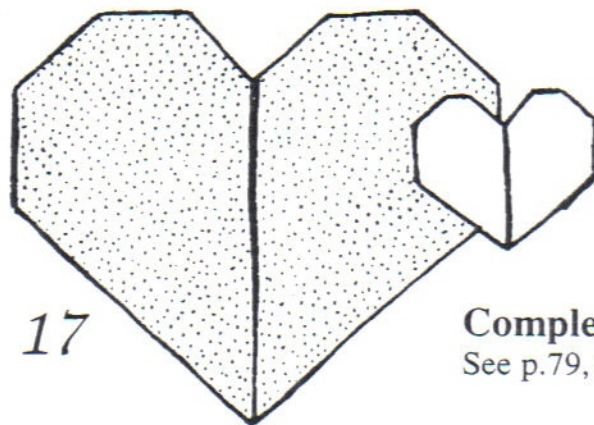
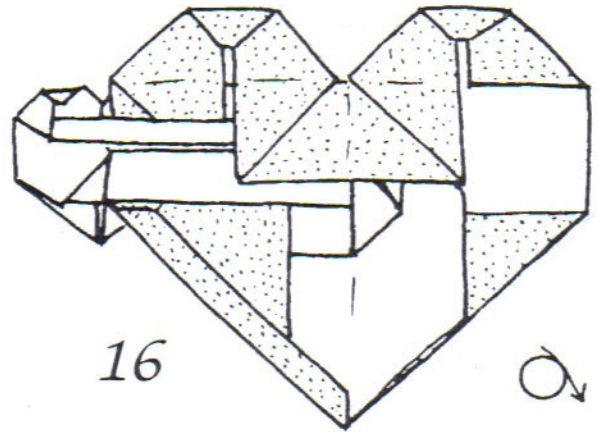
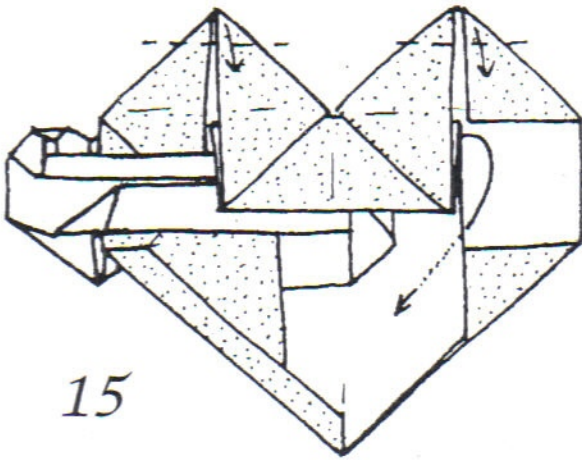
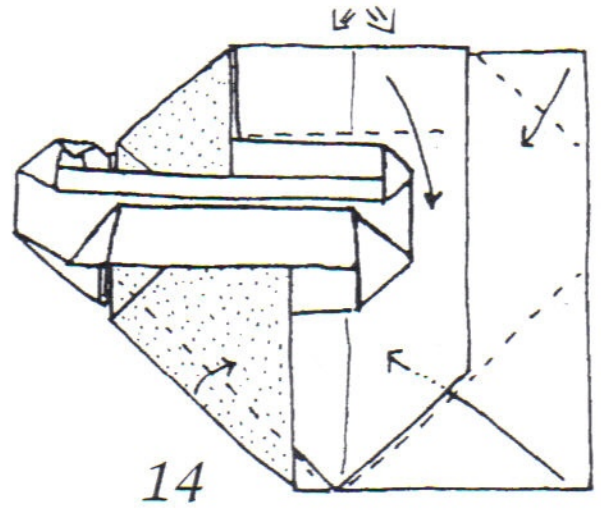
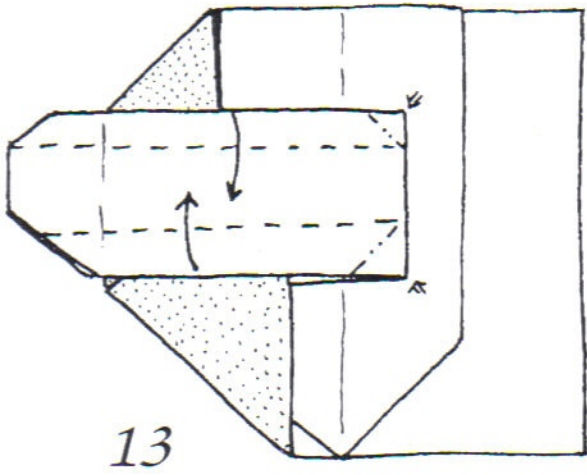

**Complete**  
See p.79, no.60



# Puppy Love

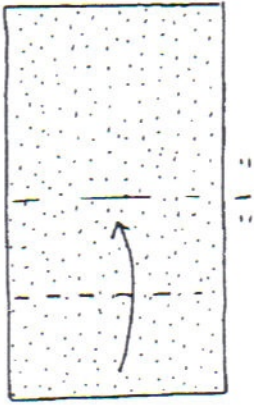

1 1 x 2 rectangle.  
Color side up.

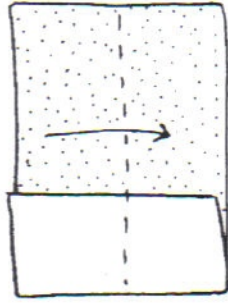

2

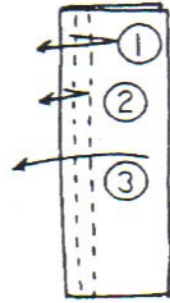

3

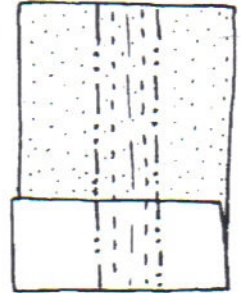

4

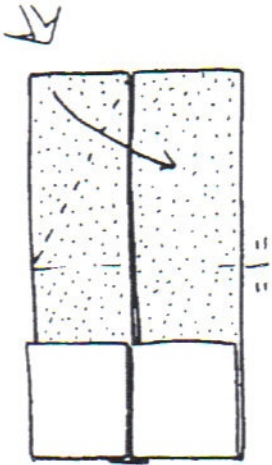

5

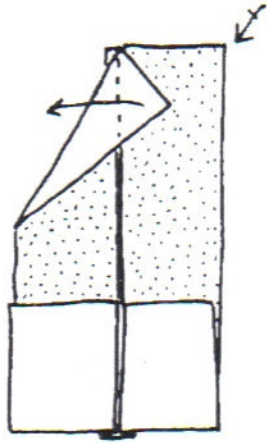

6

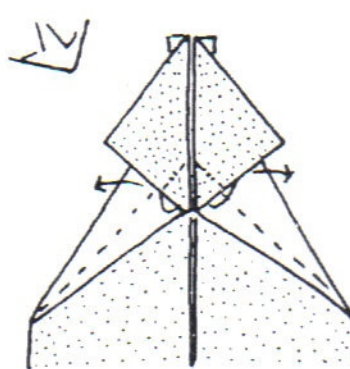

7

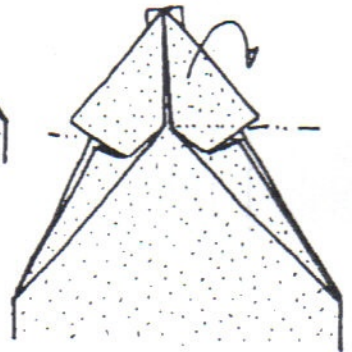

8

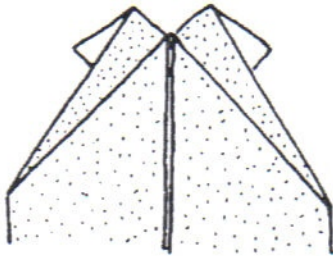

9

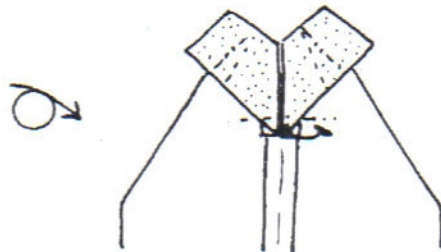

10

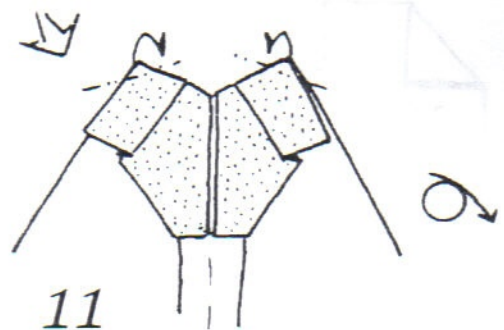

11

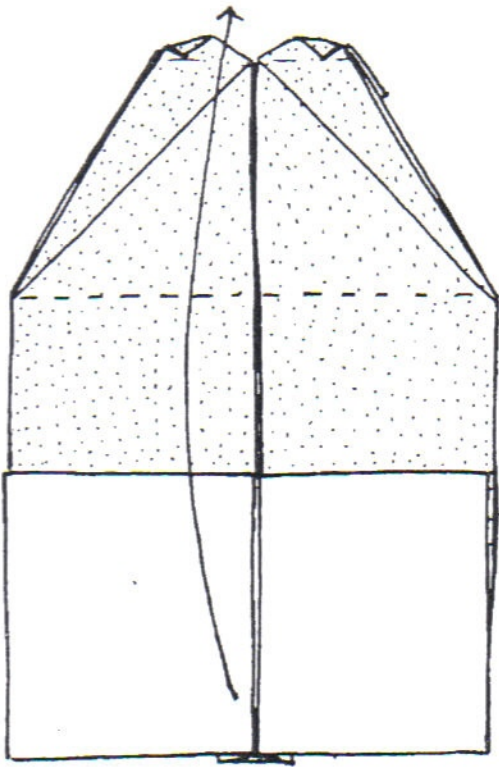

12

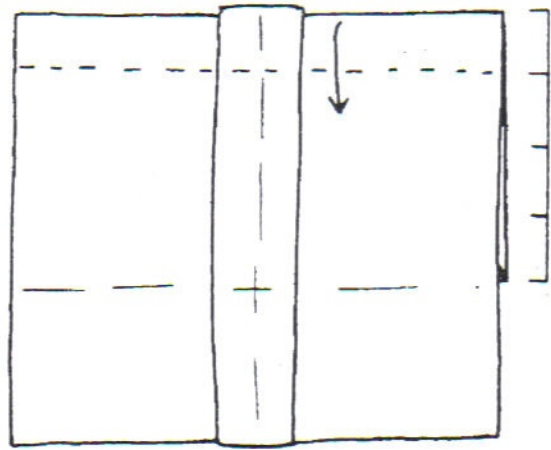

13

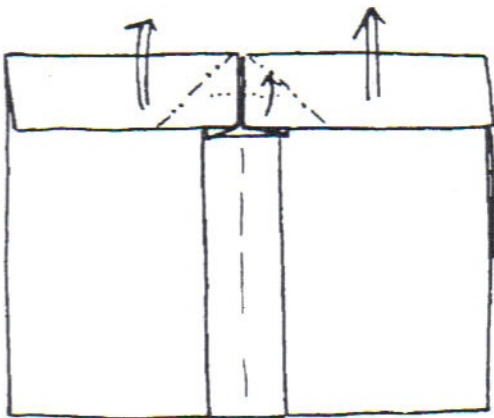

14

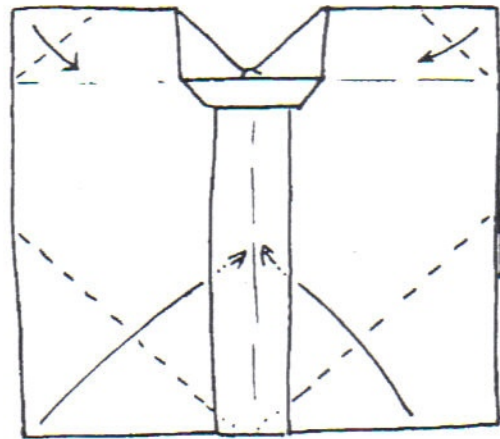

15

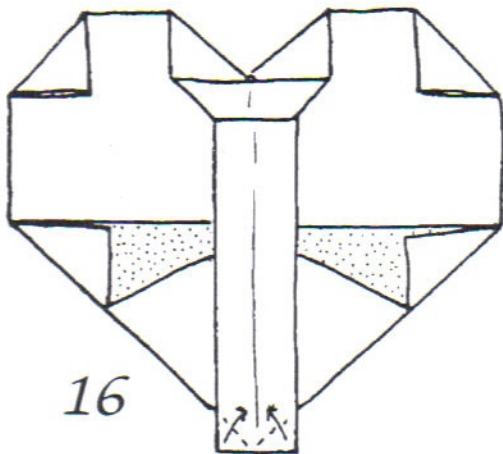

16

d

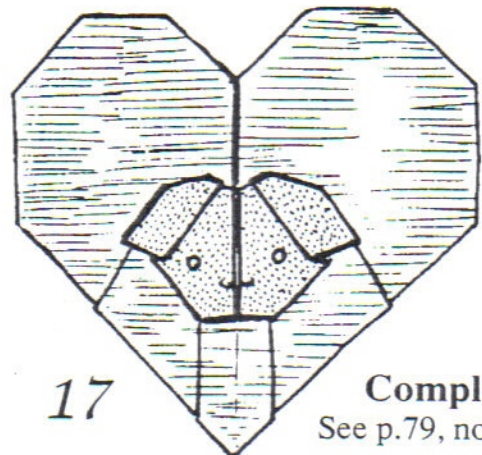

17

Complete  
See p.79, no.57

# Loving Pajaritas

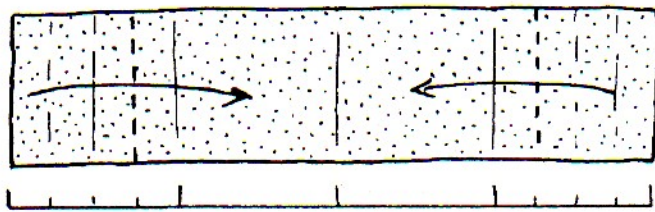

1 4 × 1 rectangle.  
Color side up.

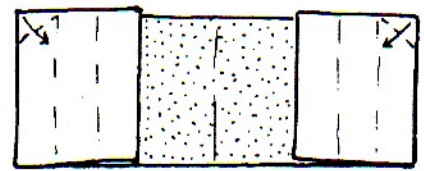

2

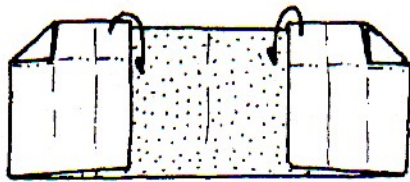

3

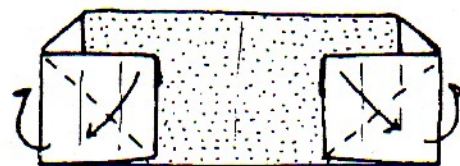

4

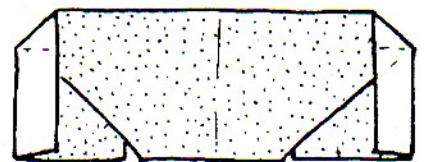

5

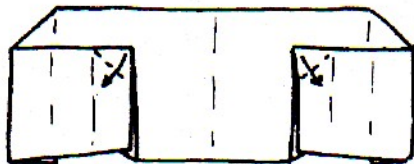

6



7

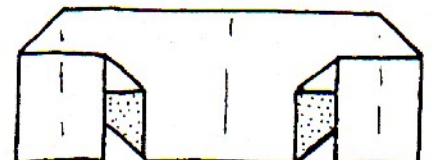

8

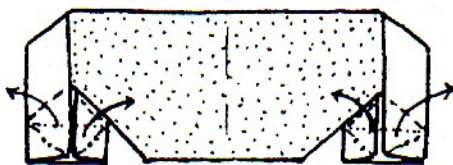

9

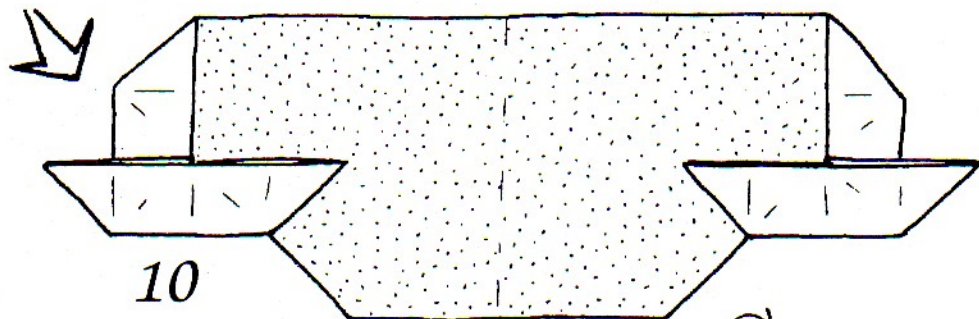

10

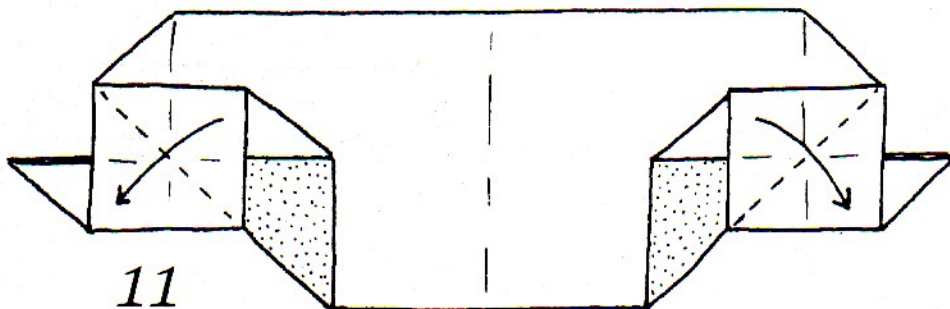

11

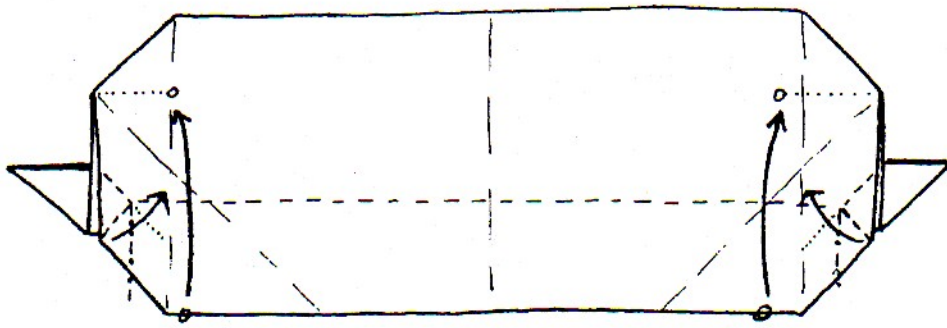

12

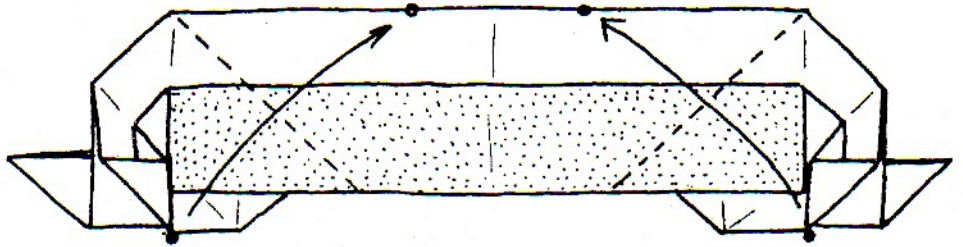

13

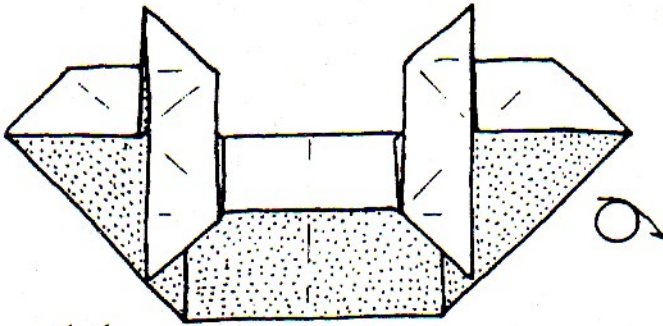

14

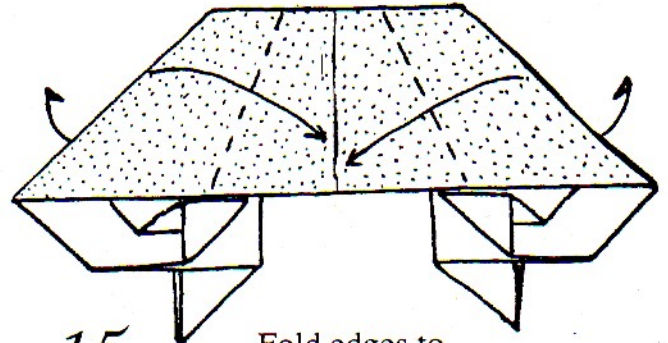

15

Fold edges to center line.

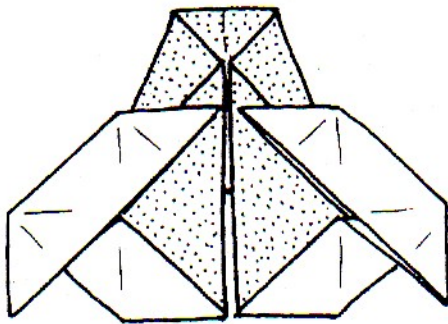

16

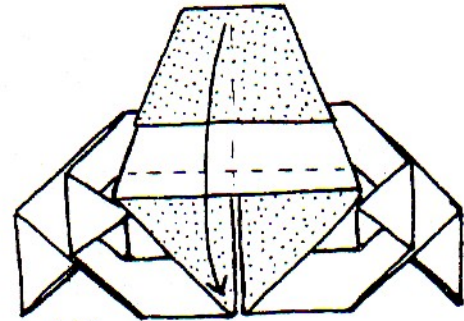

17

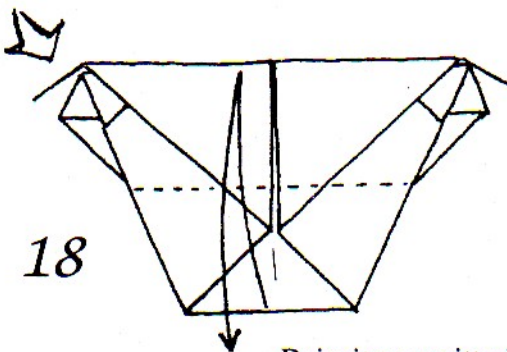

18

Pajaritas omitted.

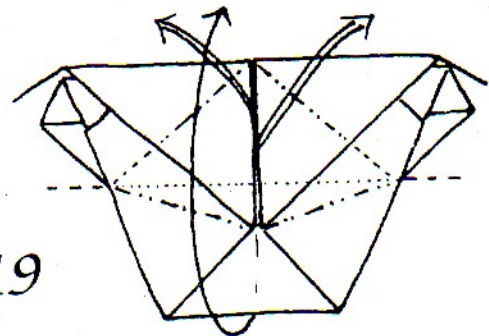

19

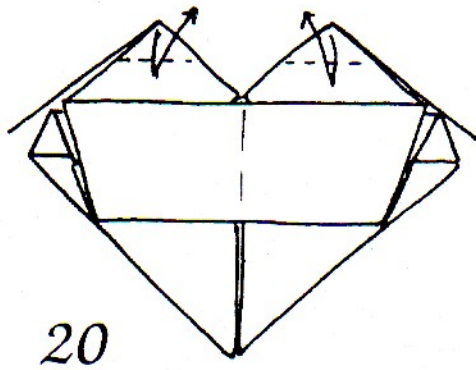

20

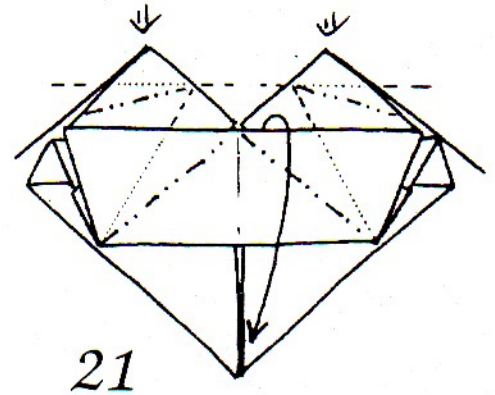

21

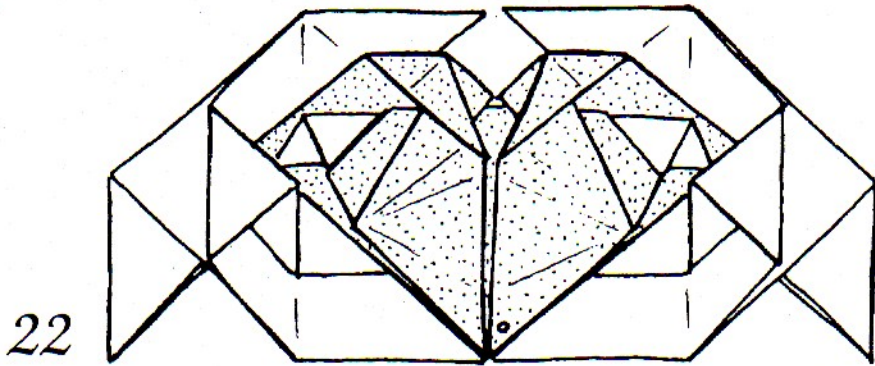

22

Lift up flap to form a stand.

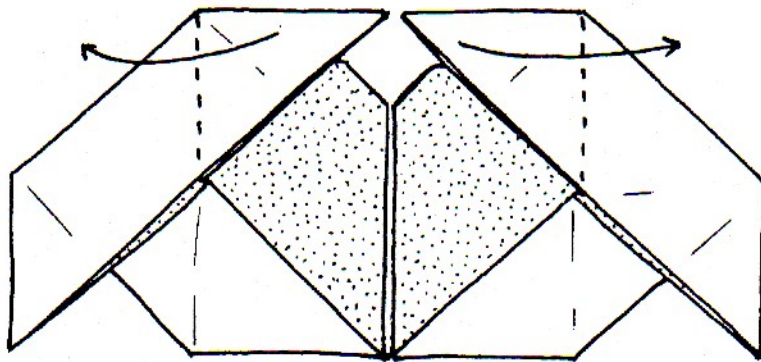

23

Model will  
stand up.

24

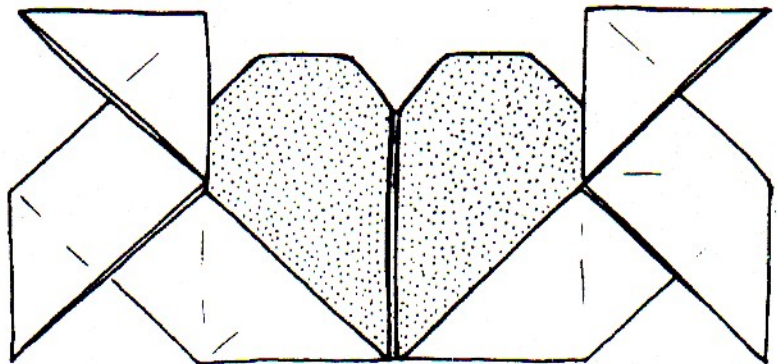

**Complete**

See p.79, no.54

# Heart Tatou

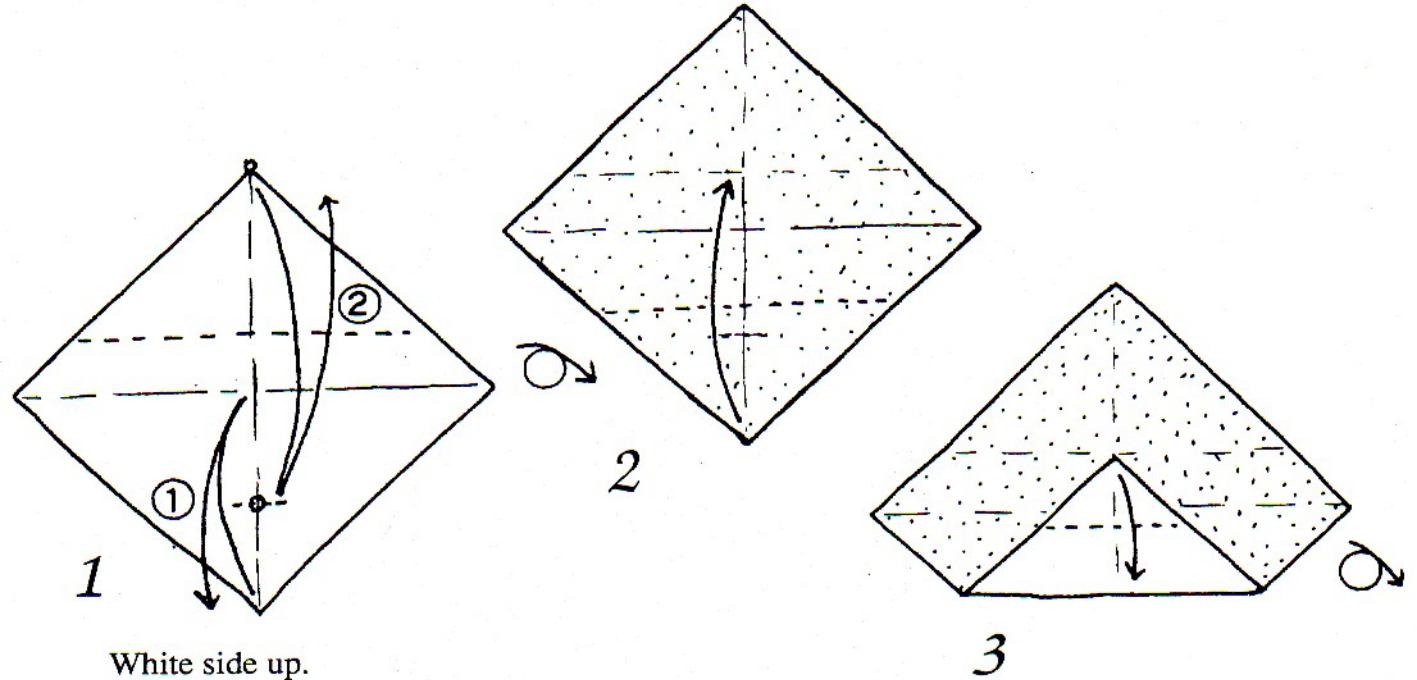

White side up.

1. Crease to mark.
2. Fold to crease mark made in 1.

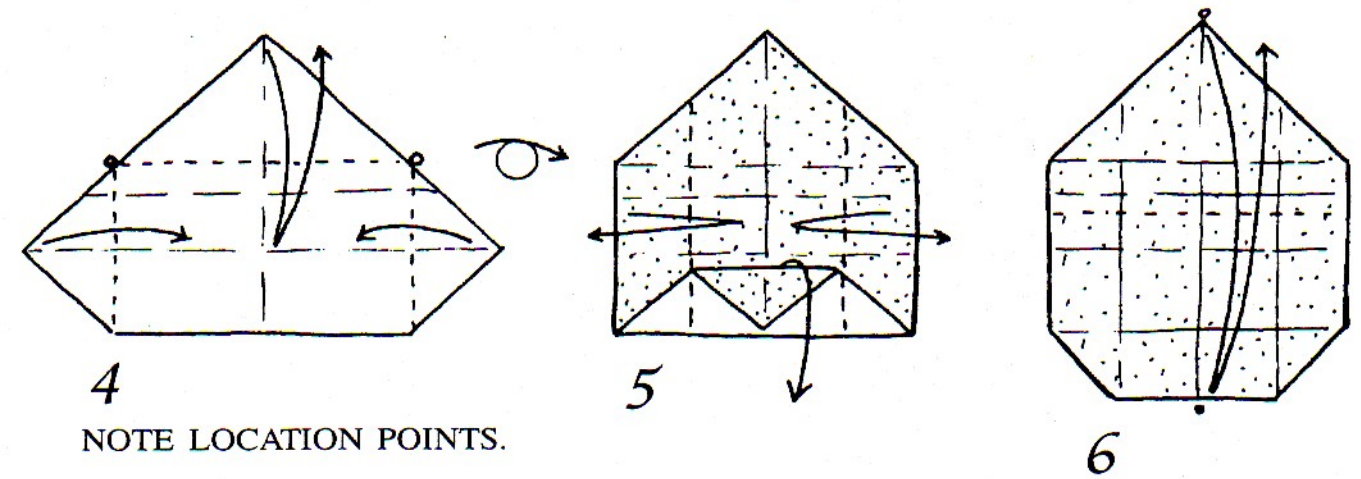

NOTE LOCATION POINTS.

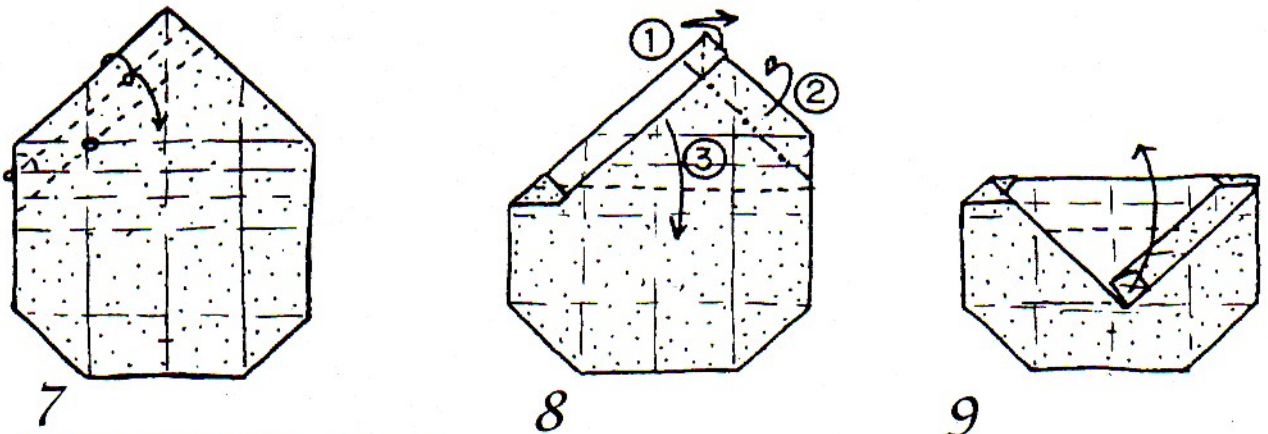

NOTE LOCATION POINTS.

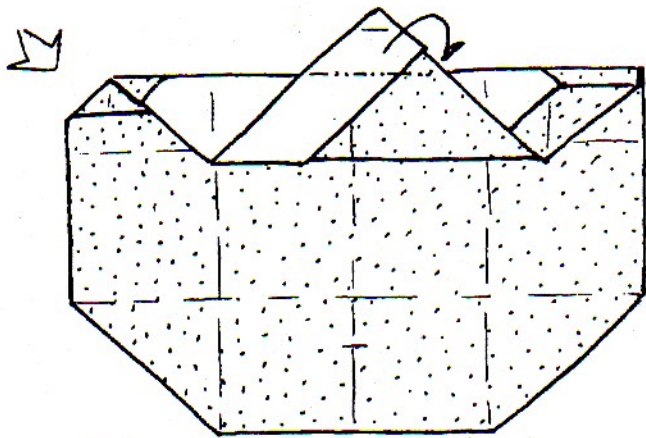

10

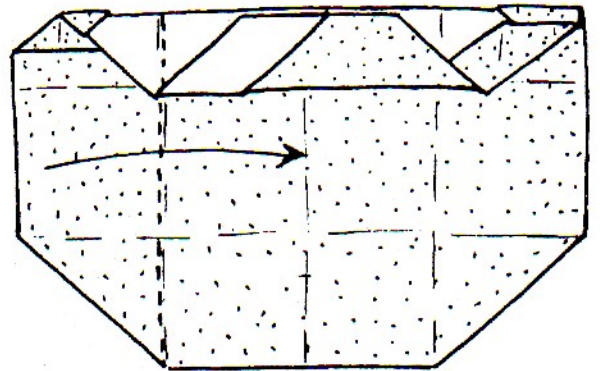

11

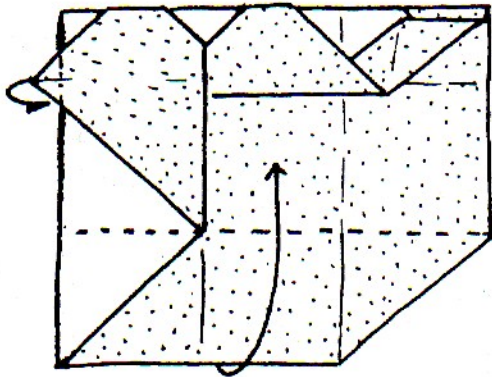

12

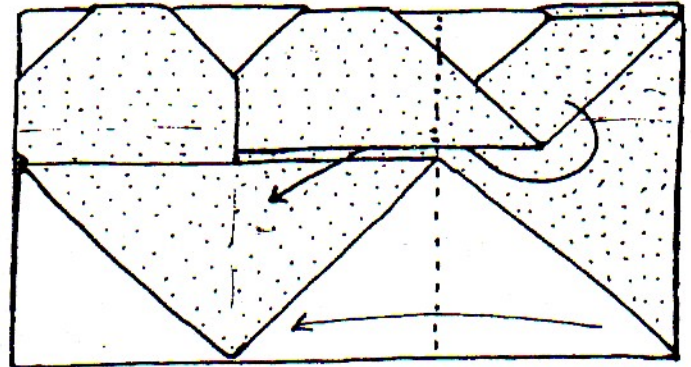

13

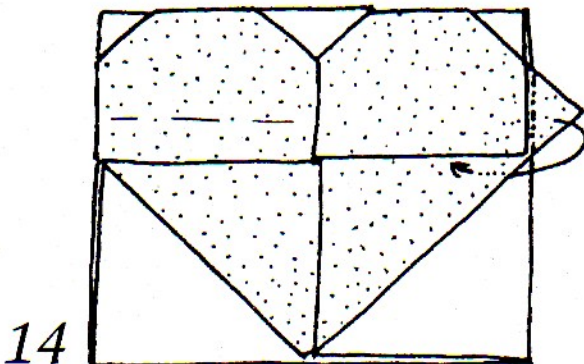

14

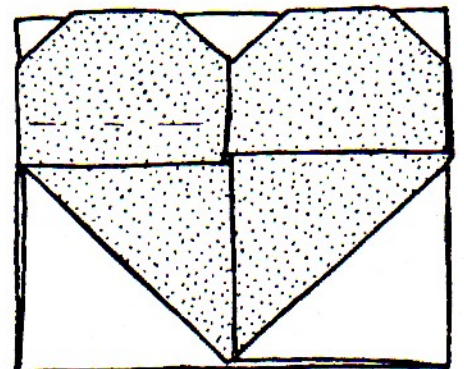

15

**Complete**  
See p.12, no.39

*Model by Jun Maekawa*

# Heart Pin

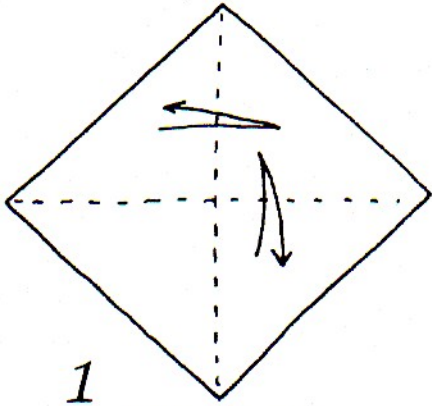

1

White side up.

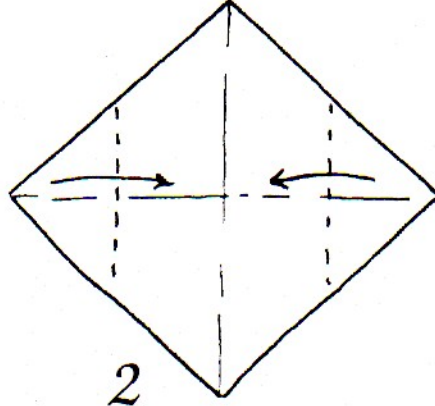

2

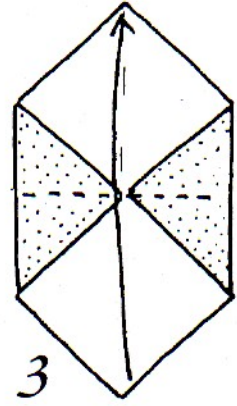

3

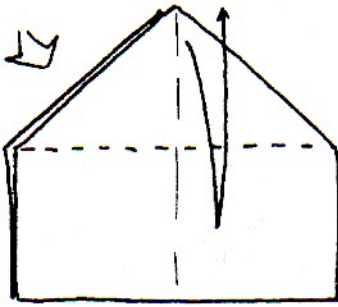

4

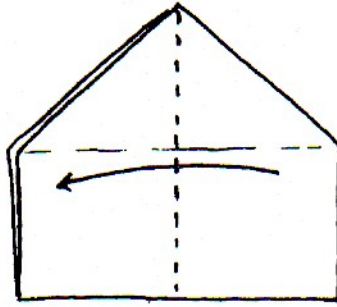

5

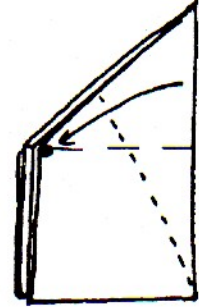

6

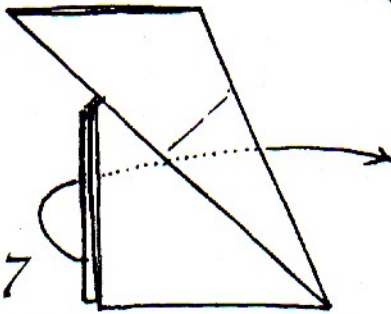

7

Release paper from behind.

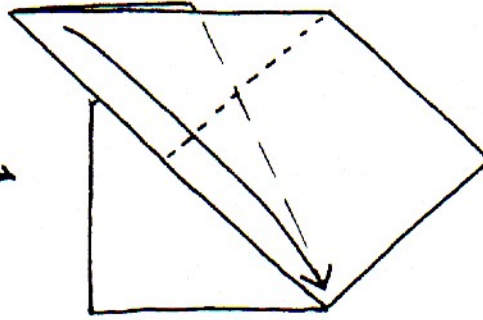

8

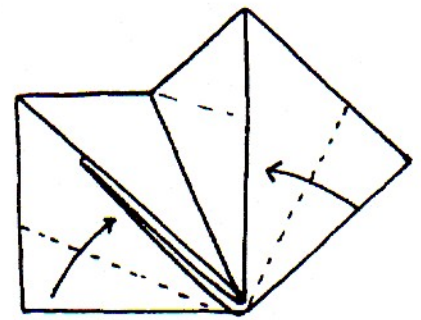

9

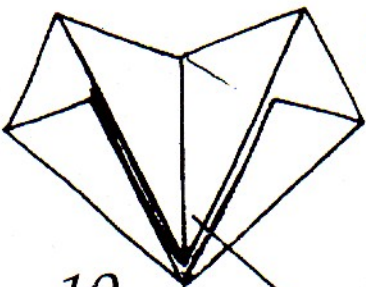

10

Use this point as a pin.

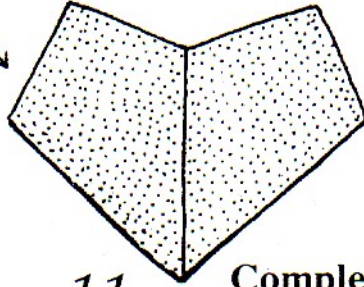

11

Complete  
See p.7, no.9

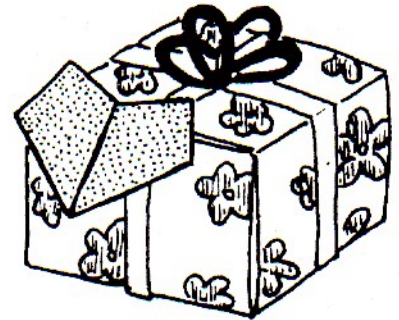

Model by Kunihiko Kasahara



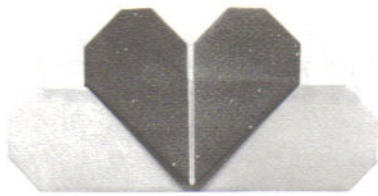

53



54

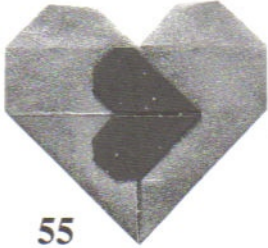

55

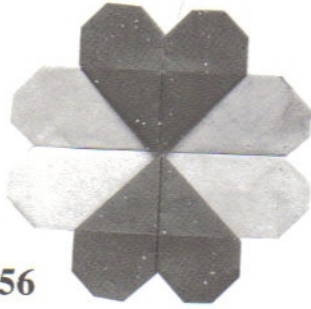

56



57

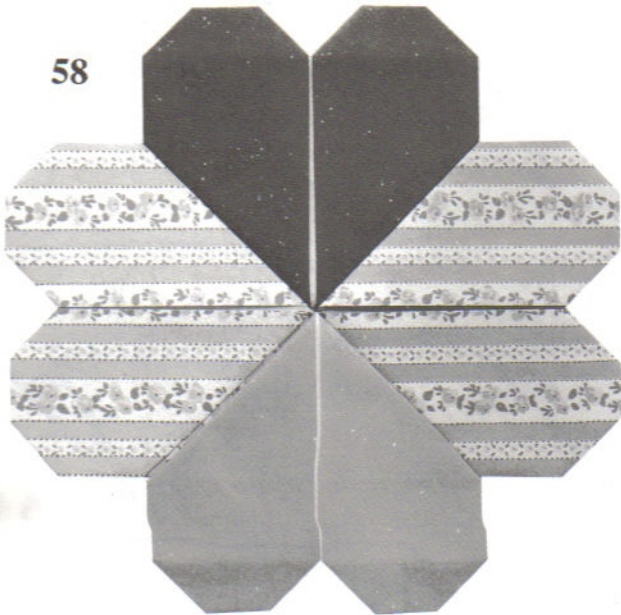

58



59



60

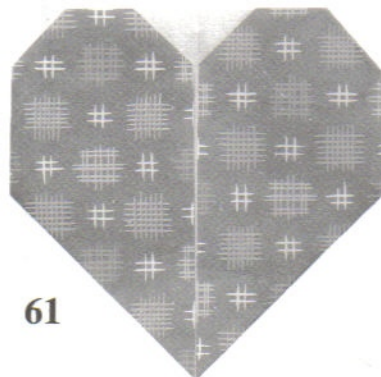

61

# Double-Sided Heart

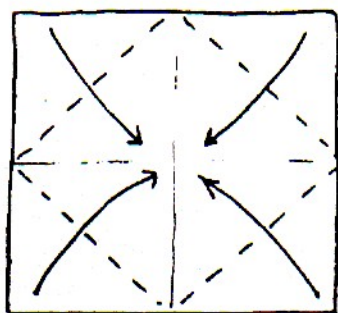

1 White side up.

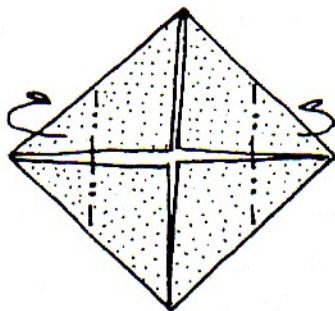

2

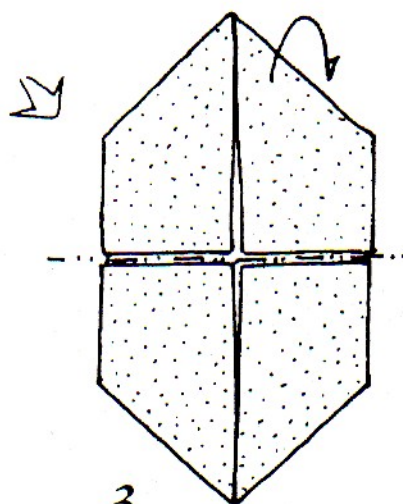

3

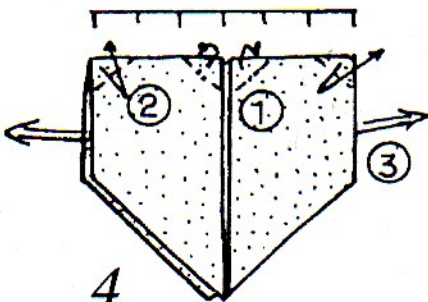

4

1. Mountain-fold.
2. Crease.
3. Unfold.

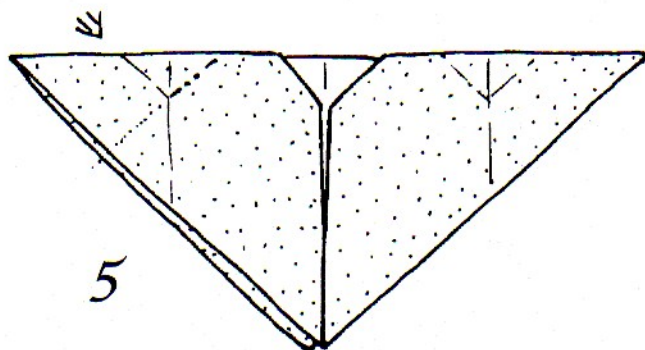

5

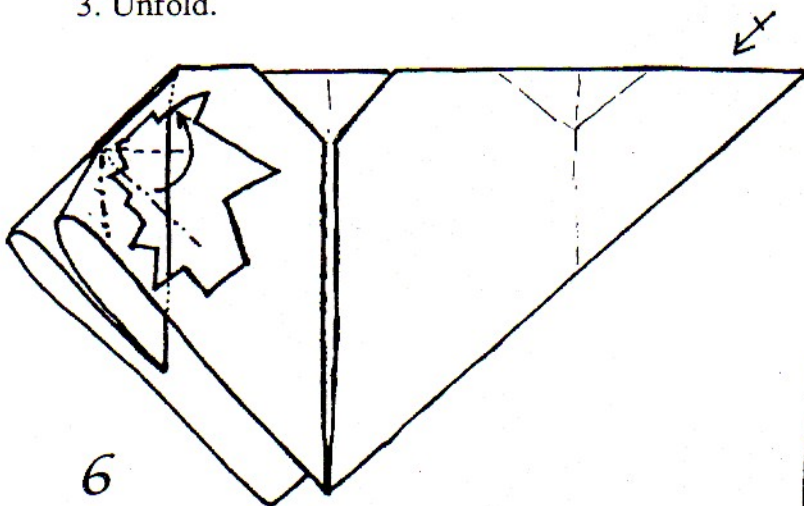

6

Model cut off to show the folds inside.  
Repeat for the right side.

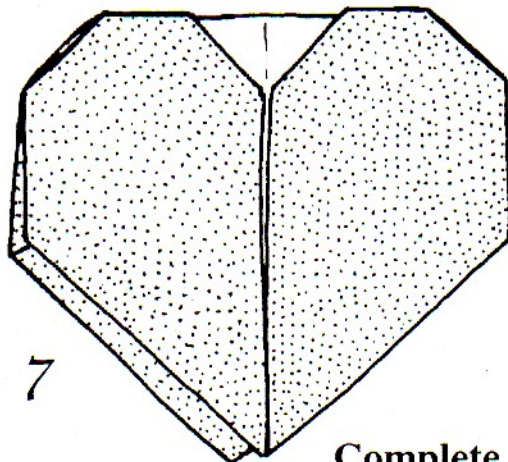

7

**Complete**  
See p.79, no.61

Model: Nick Robinson  
Drawings: Francis Ow

# Heart on Pyramid

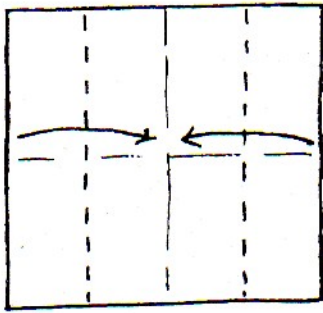

1 White side up.

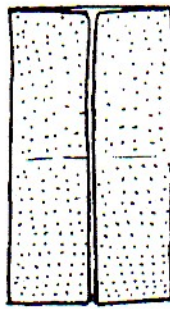

2

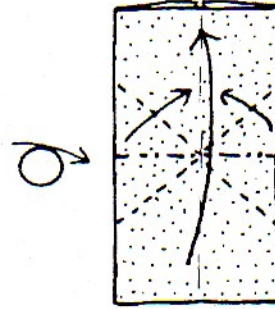

3

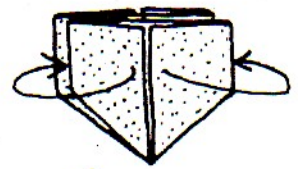

4  
Color change.

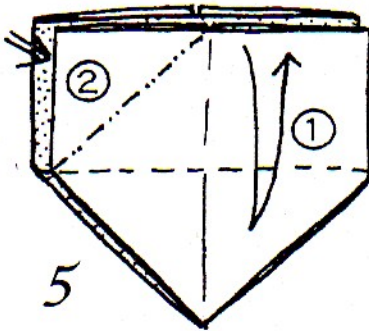

5

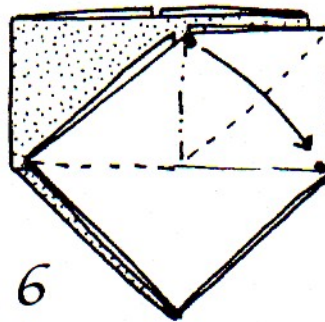

6

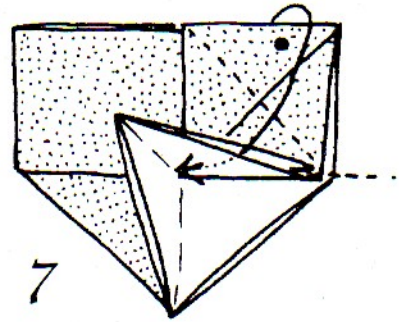

7

Fold ● up and tuck into pocket.

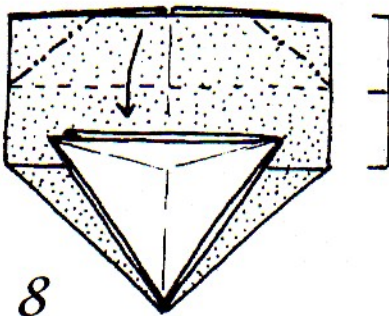

8

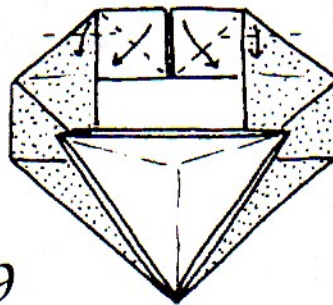

9

Form Heart.

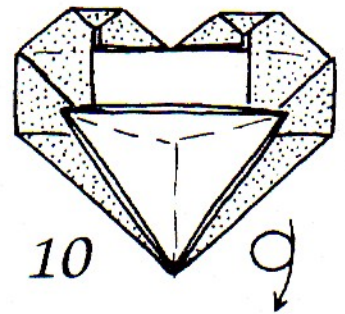

10

11

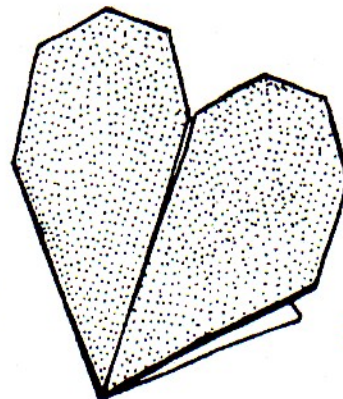

Complete  
See p.11, no.28

Model: Nick Robinson  
Drawings: Francis Ow

# Heart Module 6

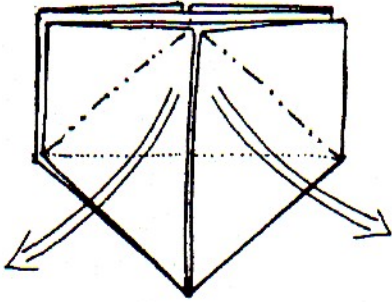

Form Heart,  
refer to  
steps 8 to 10 of  
HEART ON  
PYRAMID  
(Page 81).

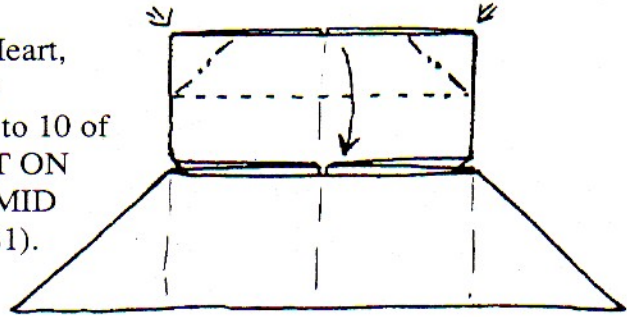

1 Step 4 of  
HEART ON PYRAMID  
(Page 81).

2 MAKE 4 MODULES.

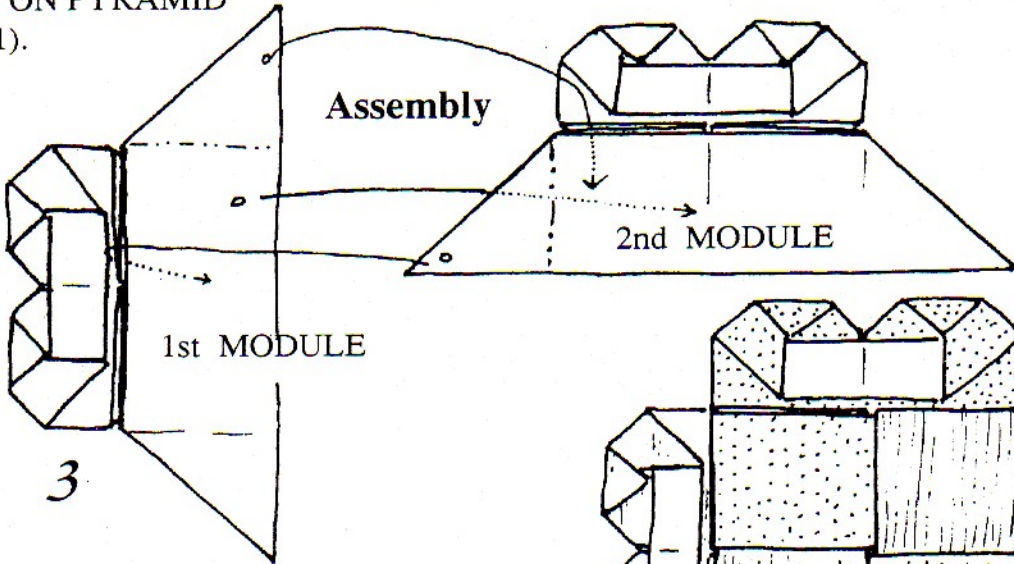

3

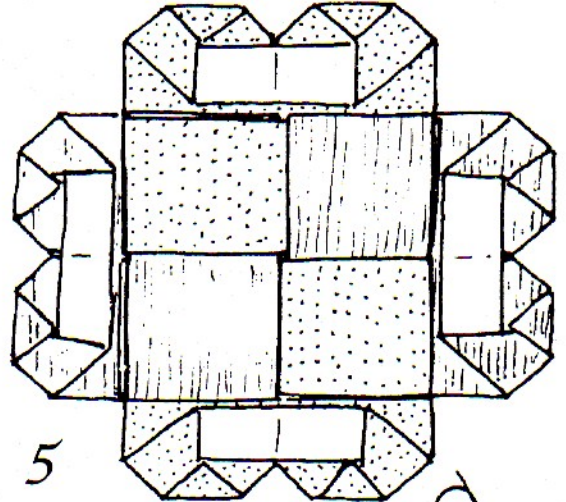

5

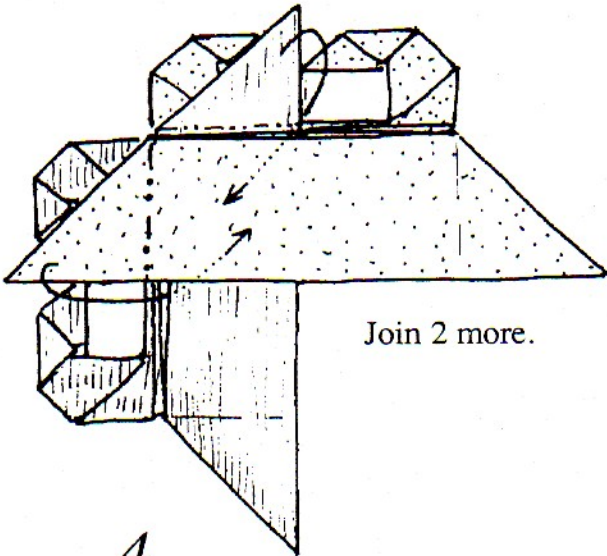

Join 2 more.

4

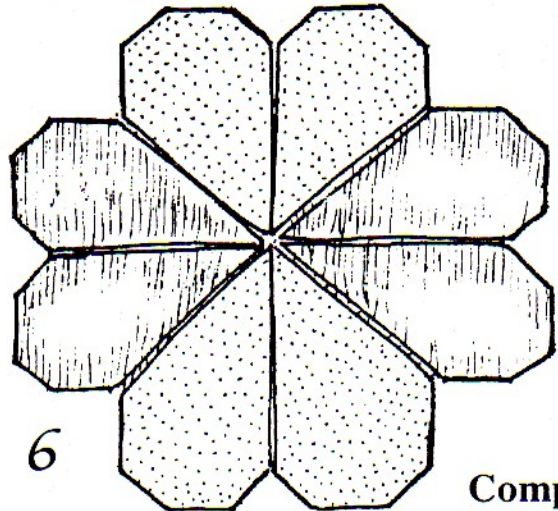

6

**Complete**  
See p.79, no.58

Module: Paul Ee  
Drawings: Francis Ow

# 3-D Heart (Petty's)

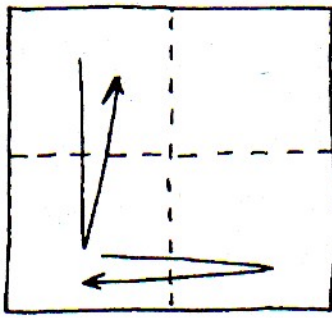

1 White side up.

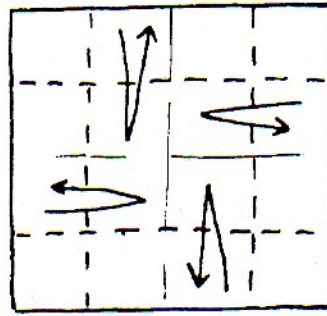

2

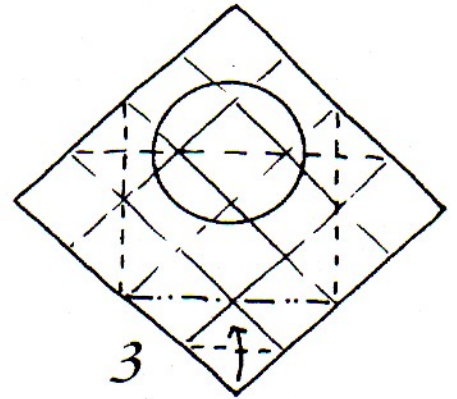

3

Add in creases and fold up bottom corner.

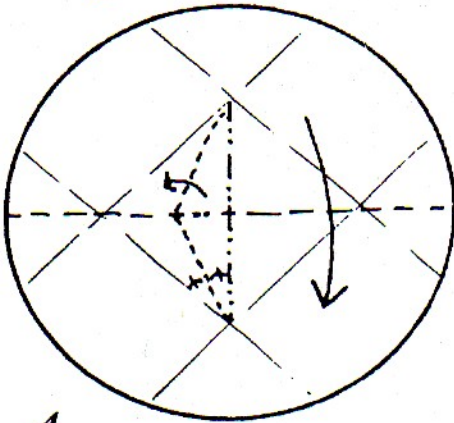

4

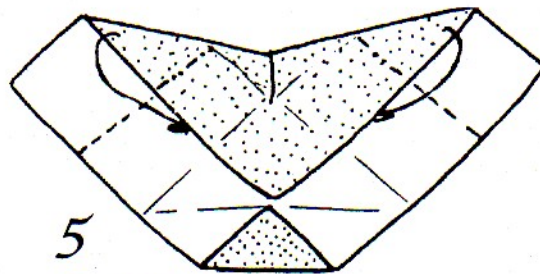

5

Model becomes 3-D, concave this side.

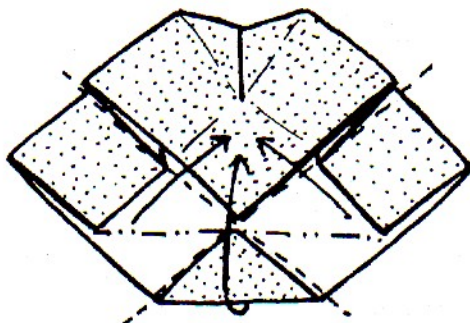

6 Waterbomb base.

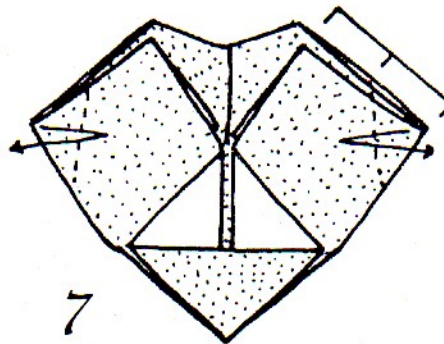

7

Pre-crease and bring the inside layers out. Sink along the crease lines made in step 7. Lock bottom layers into the valley-fold behind the top layer.

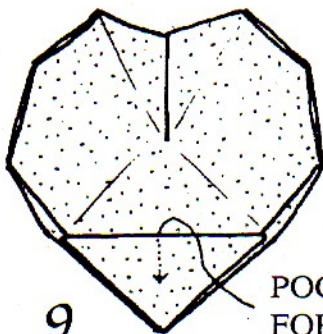

9

POCKET FOR MESSAGE.

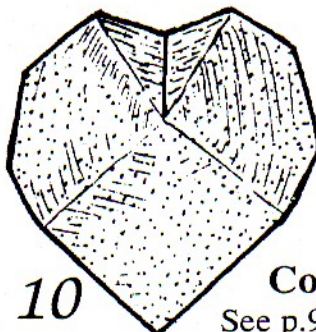

10

Complete  
See p.99, no.62

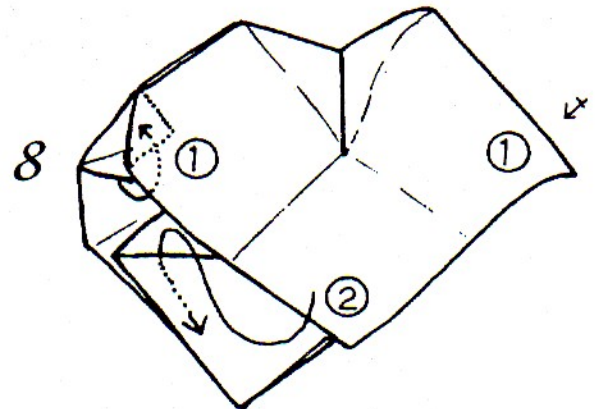

8

Model: David Petty  
Drawings: Francis Ow

# Head Over Heels

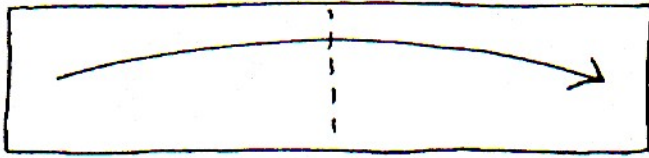

1 4 × 1 rectangle.  
White side up.

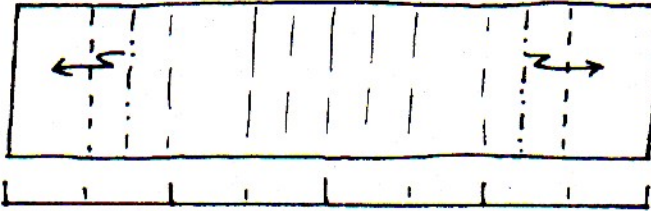
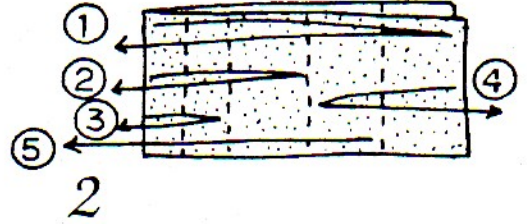

3

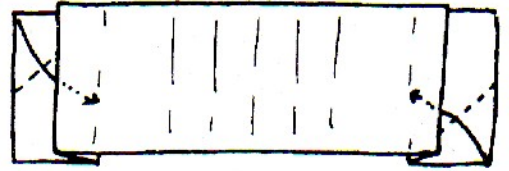

4

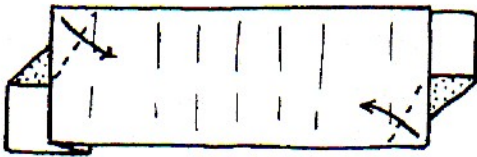

5

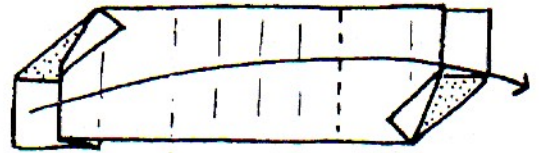

6



7 Pre-crease and return to step 6 then fold in the opposite direction along the ↑ crease line.

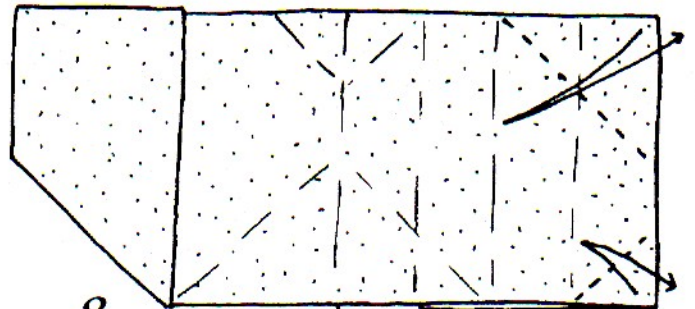

8

Crease and return to step 6.

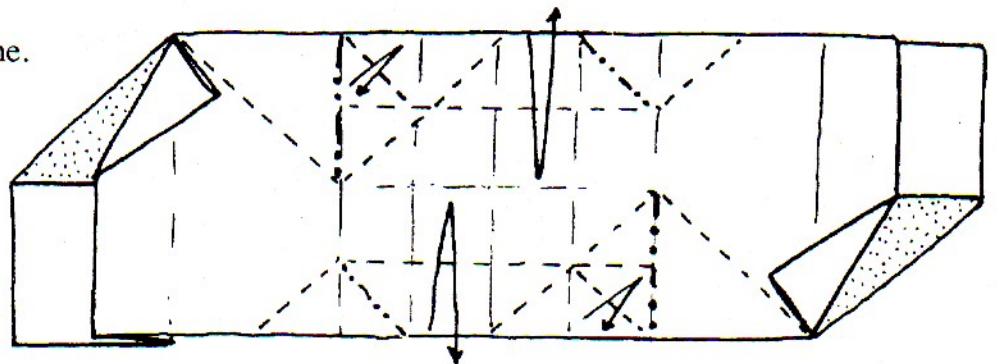

9

Correct and add in creases.

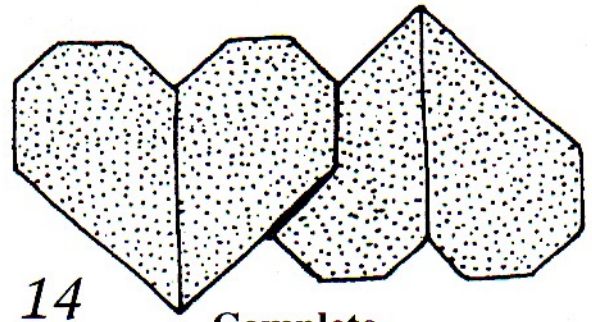
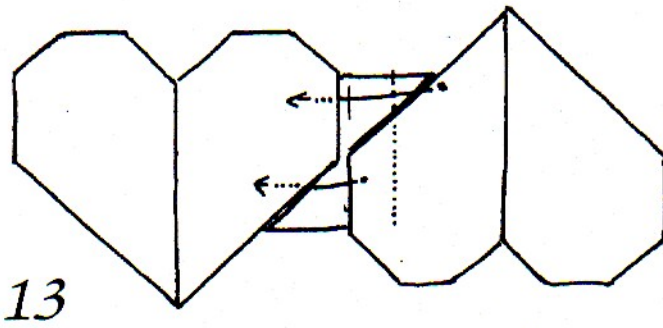
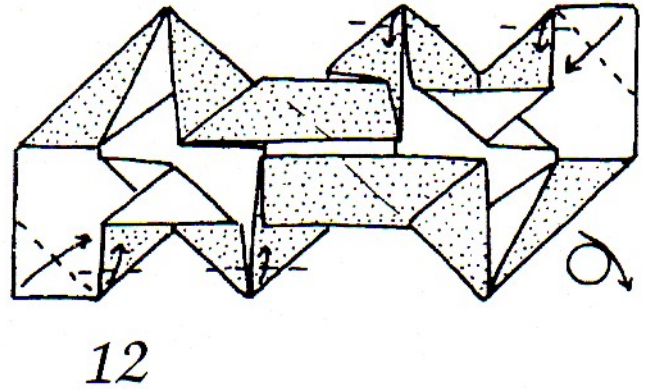
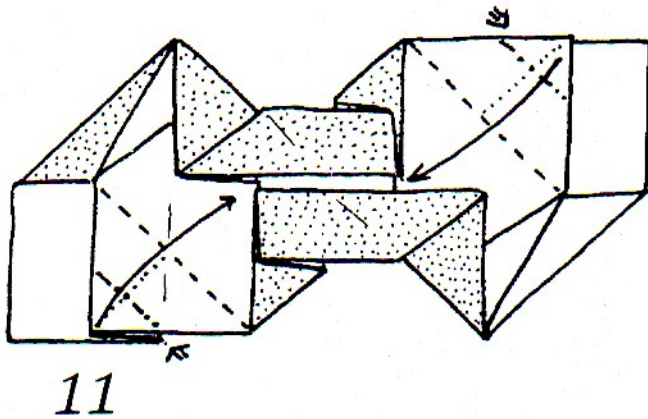
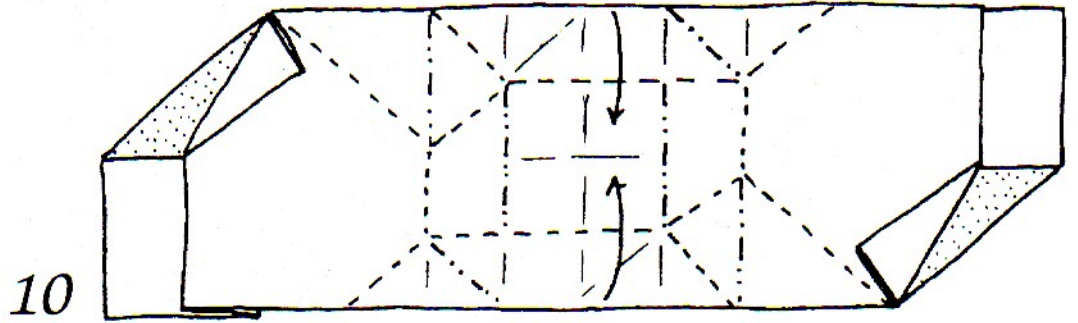

**Complete**  
See p.99, no.63

**Variation**

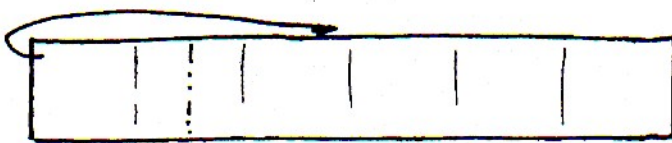

6 × 1 rectangle.

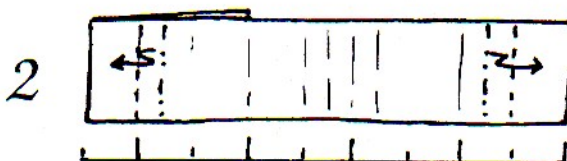

**Complete**

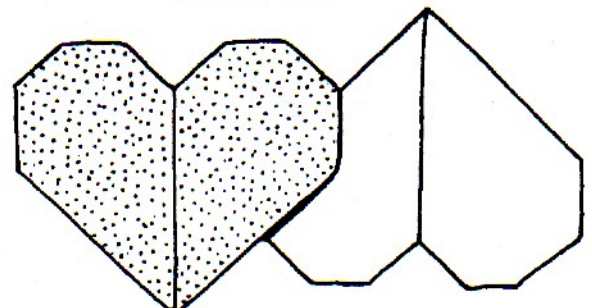

# Heart Brooch [Accroche Coeur]

Model: Francois Ziegler  
 Drawings: Francis Ow

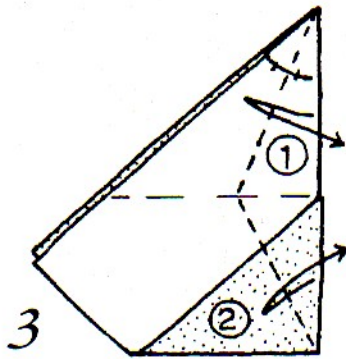
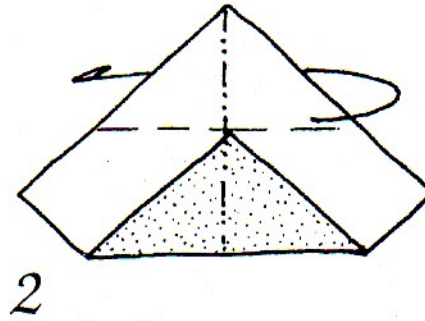
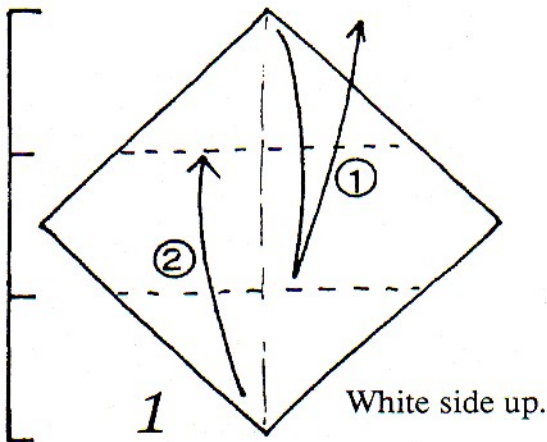

Crease 2 layers.

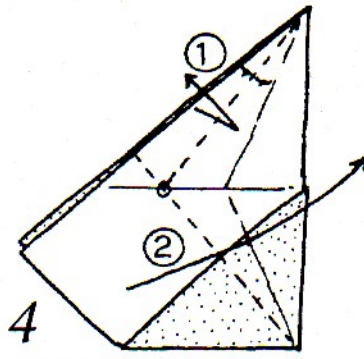

1. Crease 1 layer.  
 2. NOTE LOCATION POINTS.

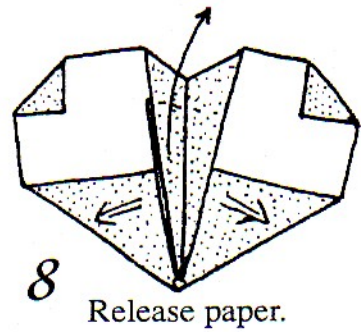
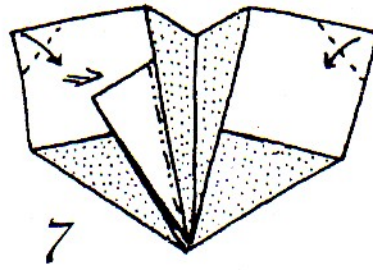
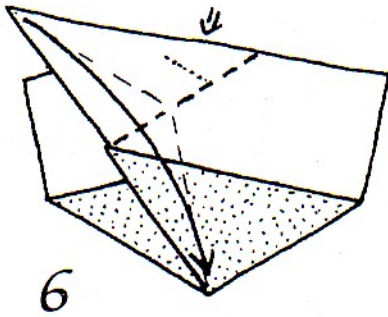
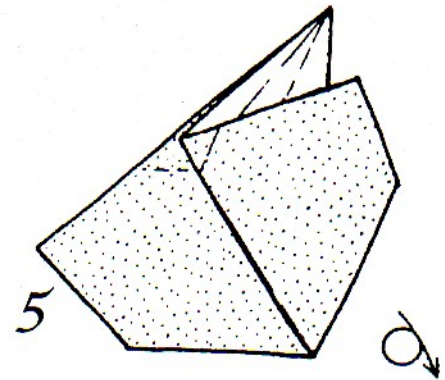

Release paper.

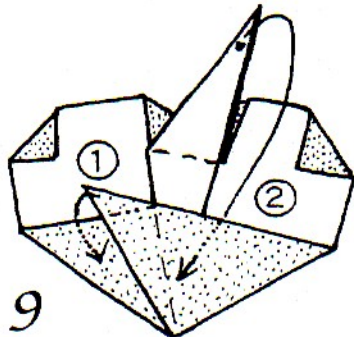

1. Mountain-fold to lock.  
 2. Insert point.

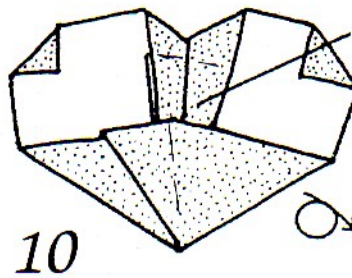

Insert this point  
 through a button-hole.

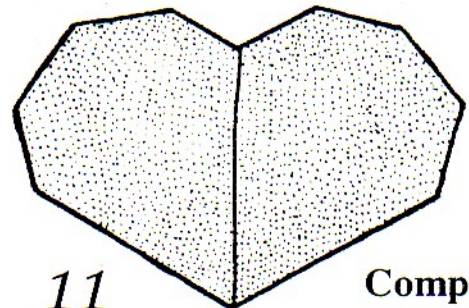

**Complete**  
 See p.6, no.8



# Winged Heart [Coeur Ailé]

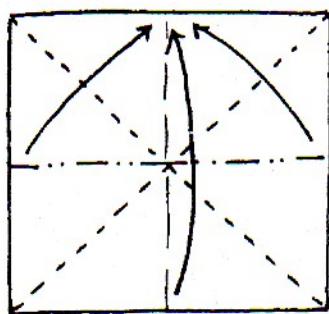

1 White side up.  
Form Waterbomb base.

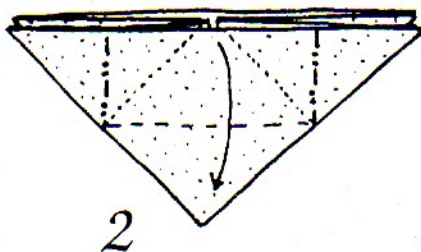

2

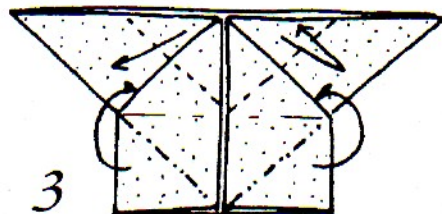

3

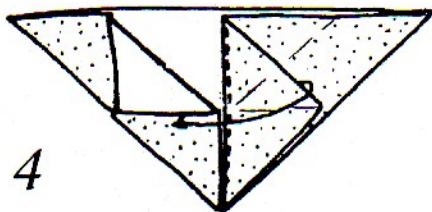

4

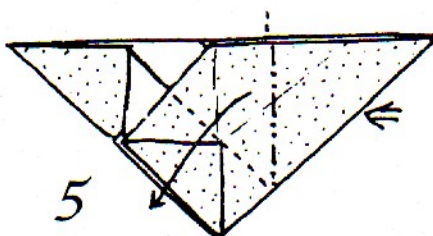

5

Squash.

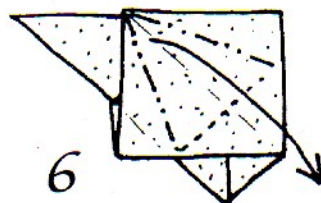

6

Petal-fold.

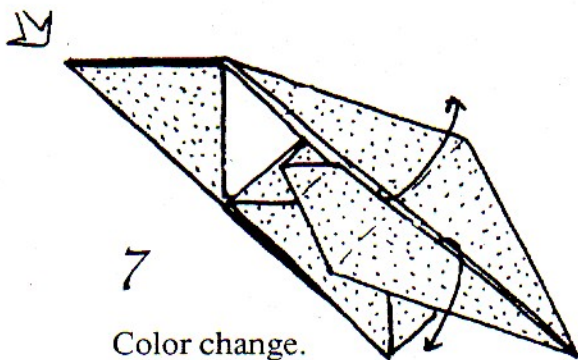

7

Color change.

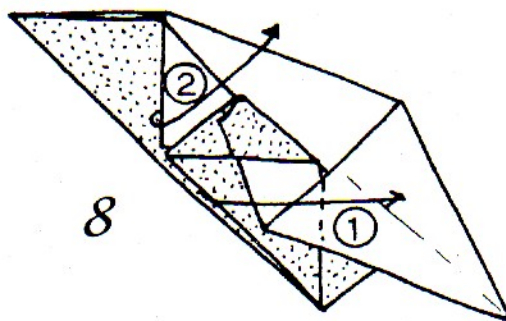

8

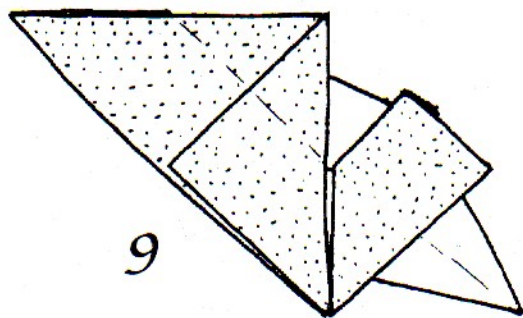

9

Repeat steps 4 to 8  
for the left side.

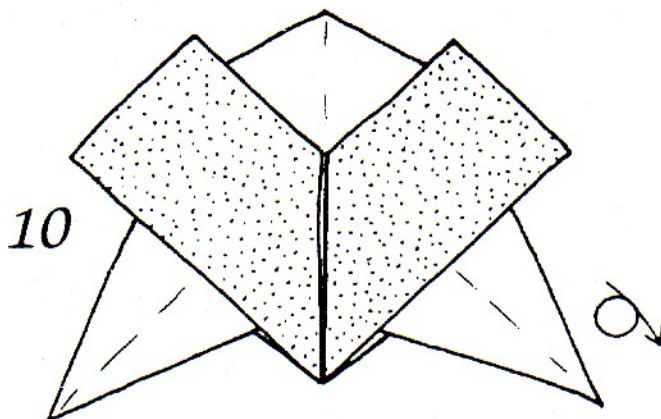

10

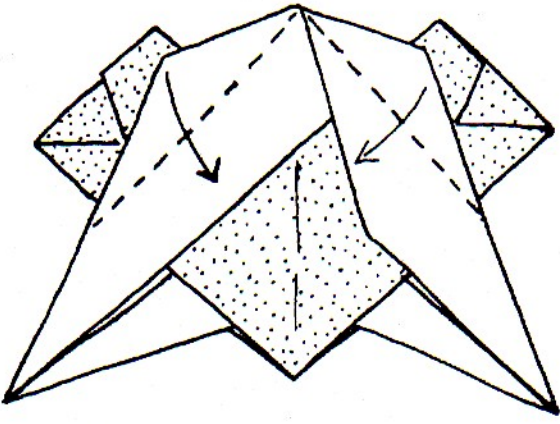

11

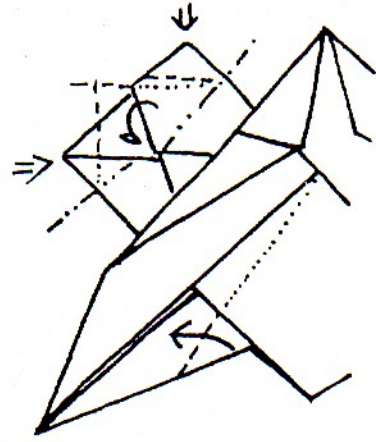

12

Repeat above folds for the right side.

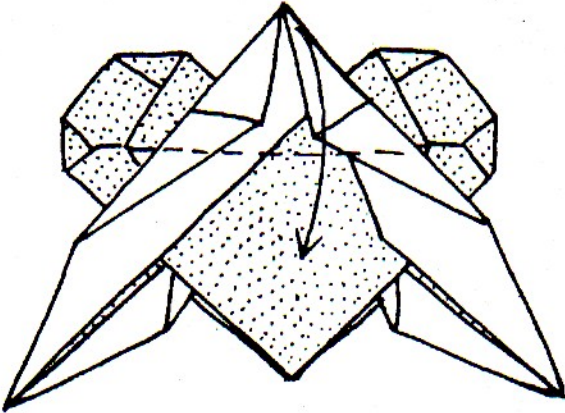

13

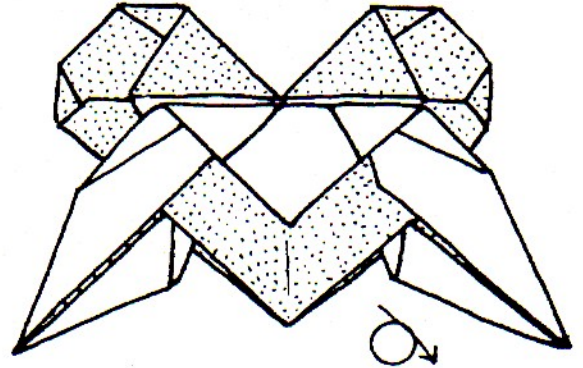

14

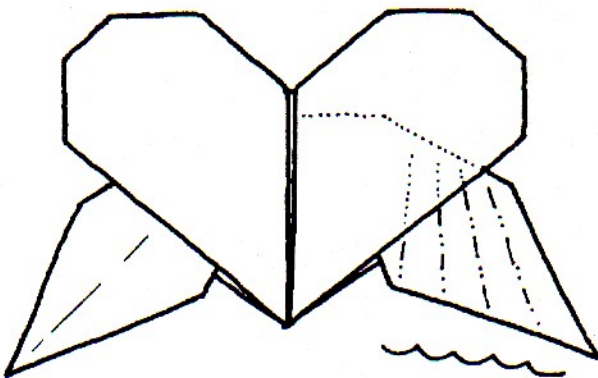

15 Pleat and shape the wings.

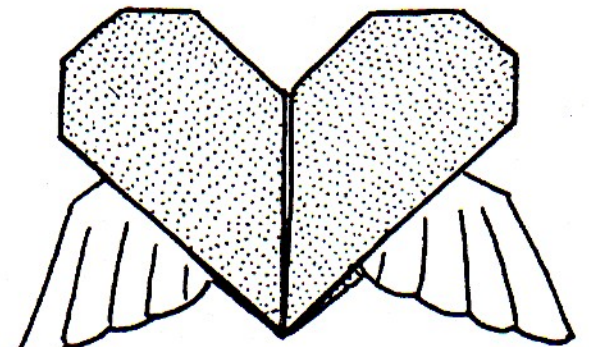

16

Complete  
See p.10, no.25

# Flying Heart

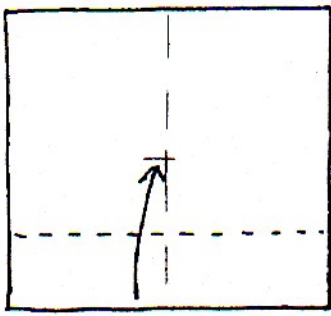

1 White side up.

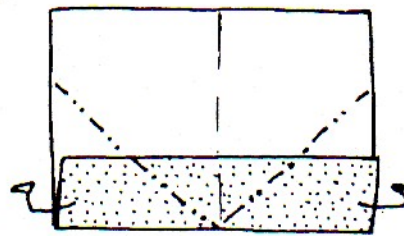

2

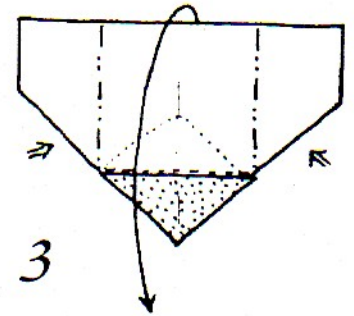

3

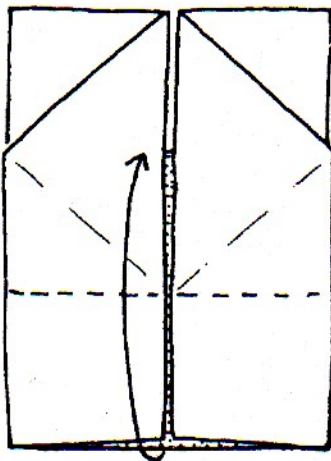

4

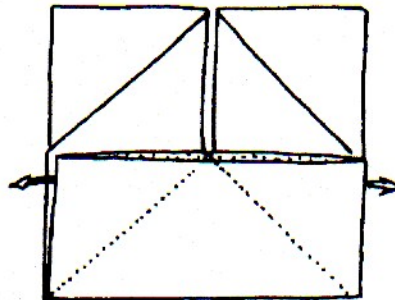

5

Release paper.

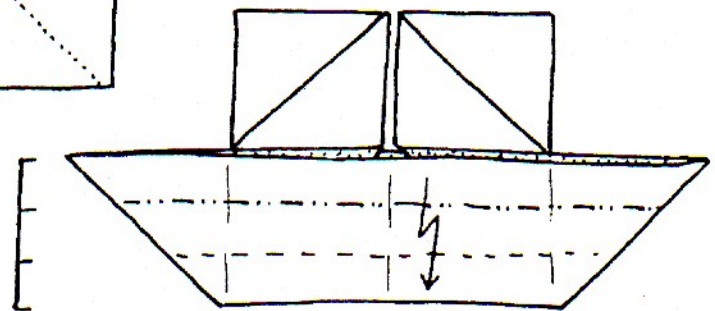

6

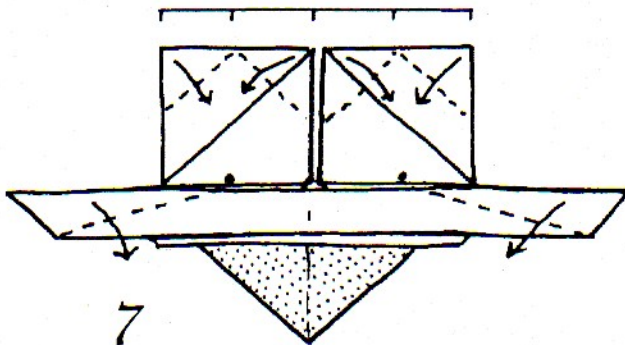

7

NOTE LOCATION POINTS.

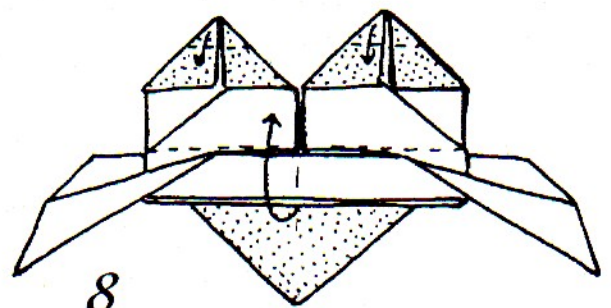

8

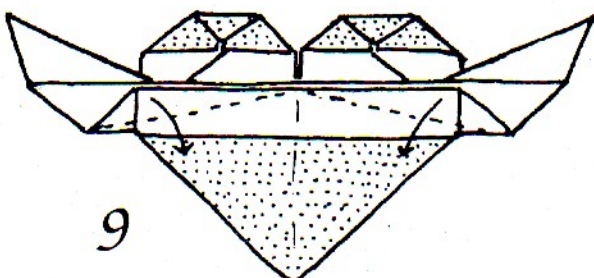

9

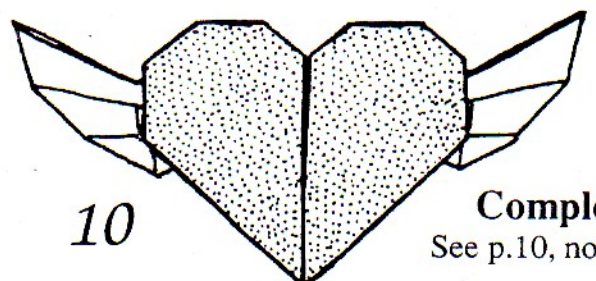

10

**Complete**  
See p.10, no.23

# A Heart for Two

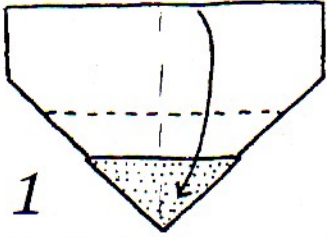

1

Step 3 of  
FLYING HEART  
(Page 89).

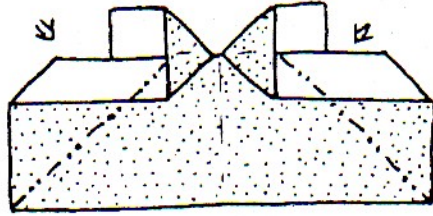

2

Reverse-folds.

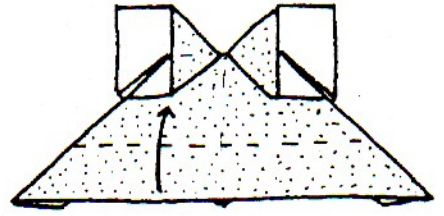

3

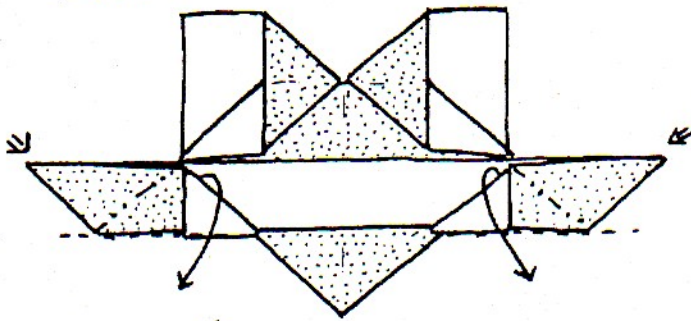

4

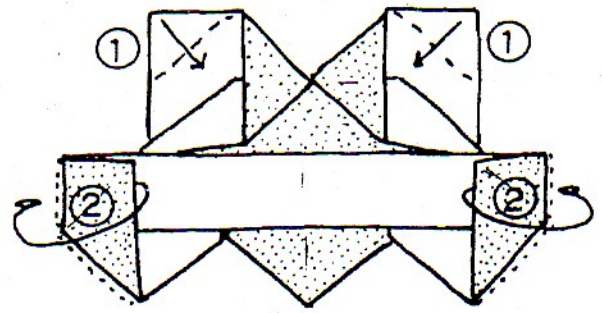

5

1. Valley fold.  
2. Color change.

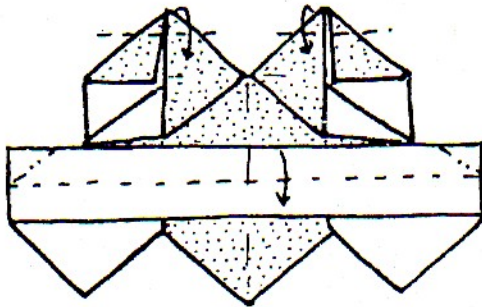

6

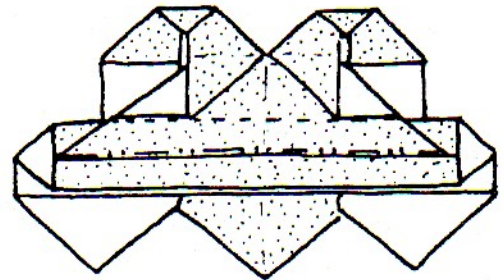

7

Pleat.

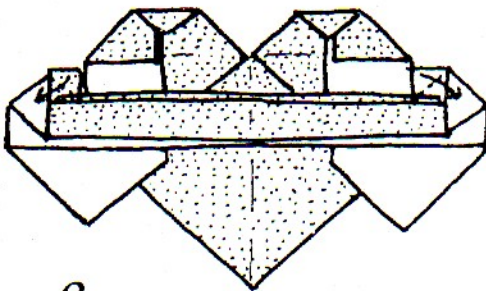

8

Shape the two  
smaller Hearts.

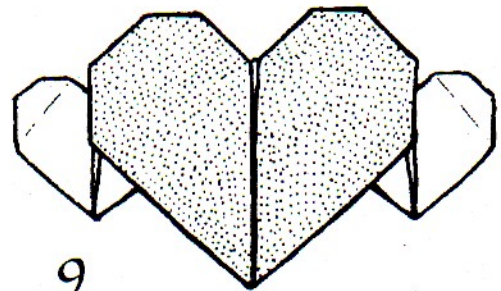

9

**Complete**

See p.99, no.64

# Love Birds

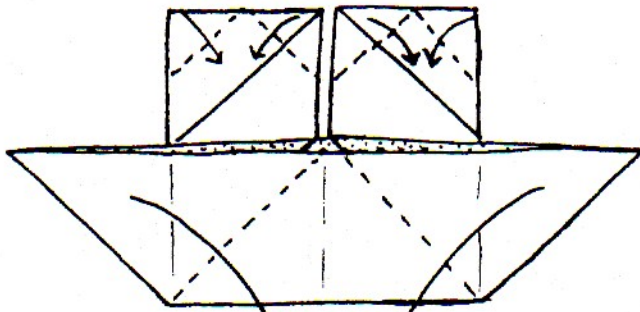

1 Step 6 of  
FLYING HEART  
(Page 89).

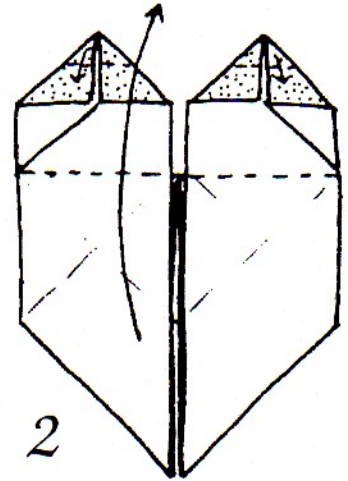

2

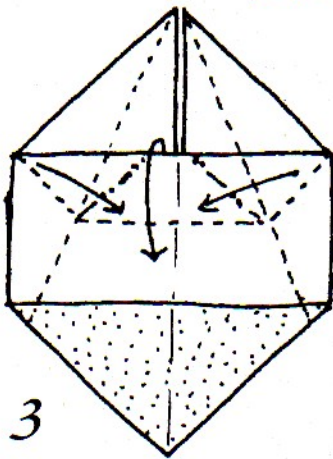

3

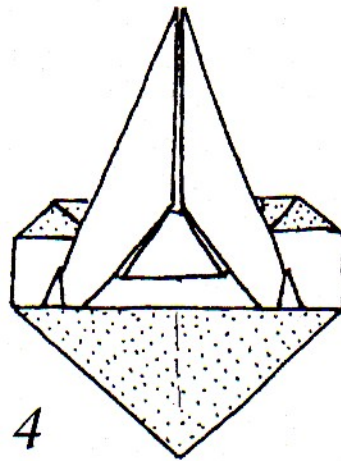

4

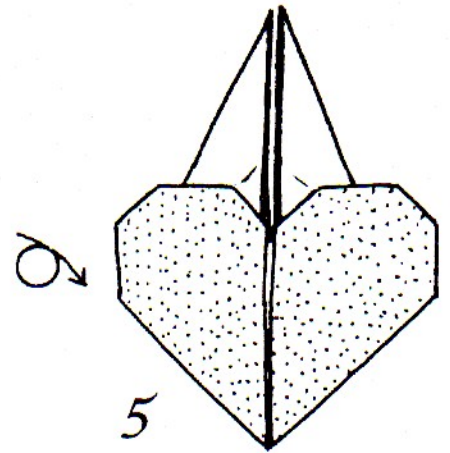

5

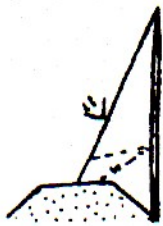

6

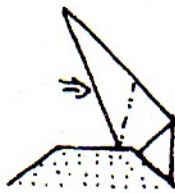

7



8



9

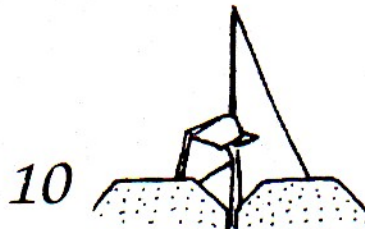

10

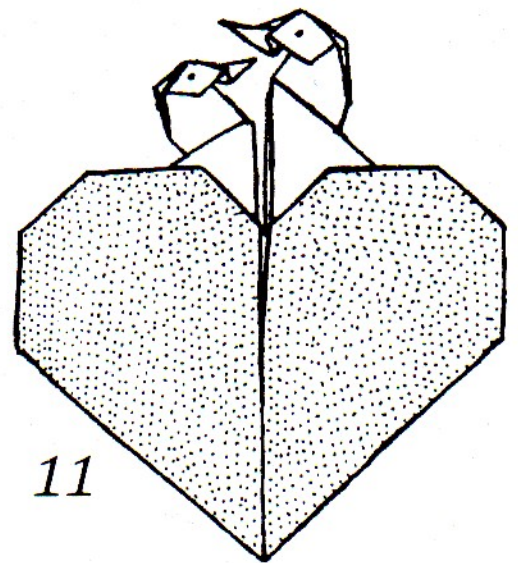

11

Repeat steps 6 to 10 to form  
another Bird on the right side.  
Position the Birds to taste.

**Complete**  
See p.5, no.5

# Love Dove

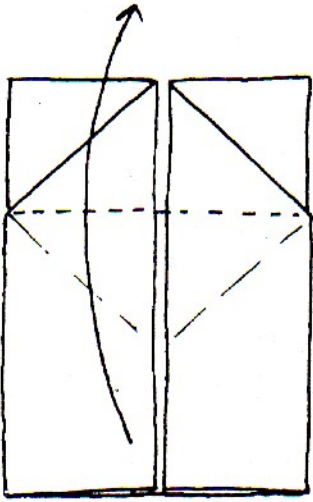

1 Step 4 of  
FLYING HEART  
(Page 89).

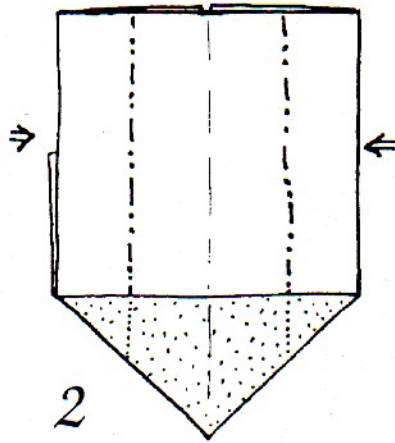

2 Sink.

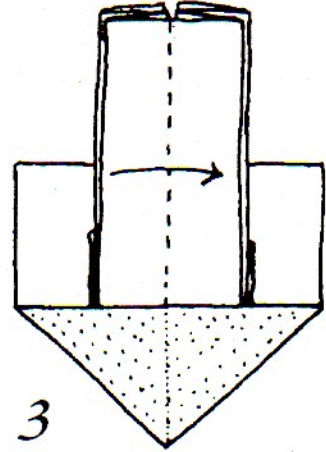

3 Book-fold all the  
pleats to the right.

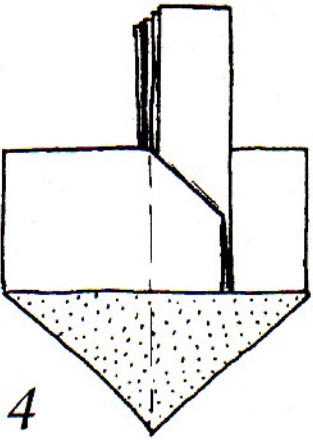

4

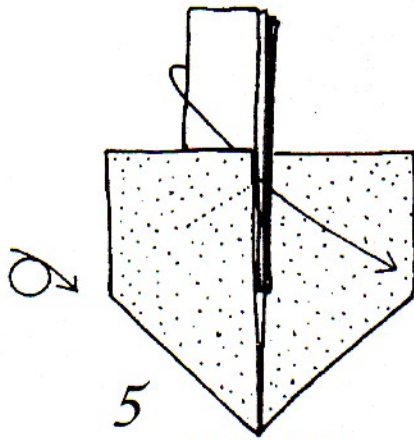

5 Vally-fold.

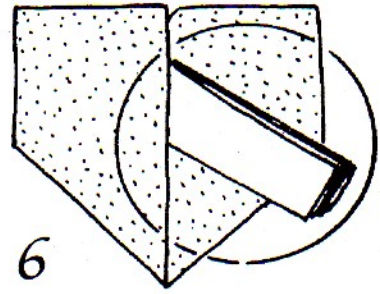

6

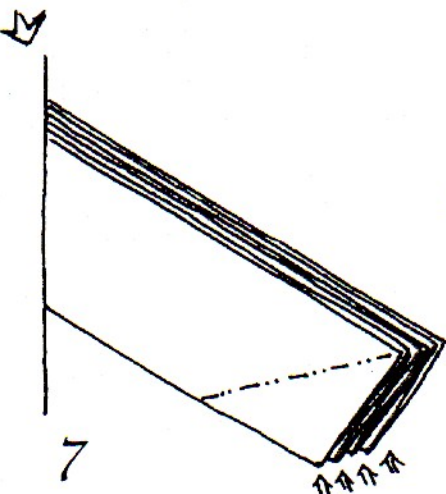

7

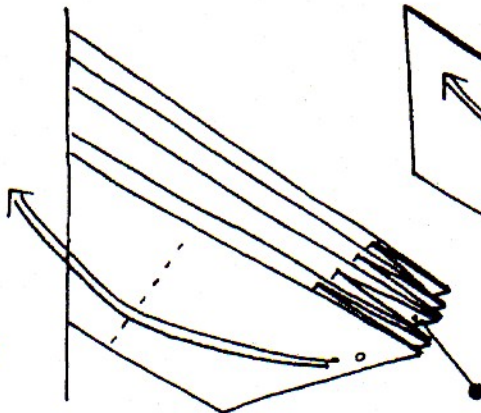

8 Hold the middle  
point and stretch  
the first point.

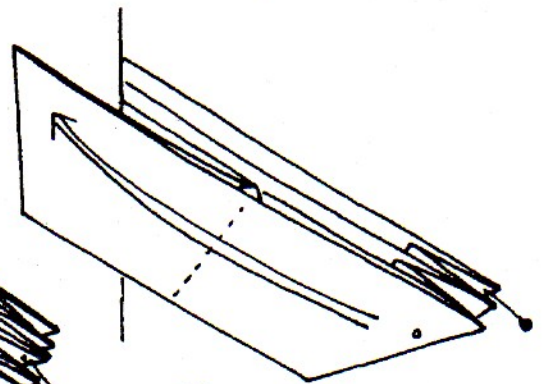

9

Hold the last  
point and stretch  
the middle point.

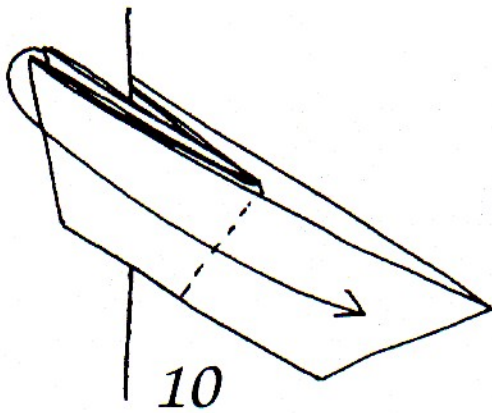

10

Return all the points to the right.

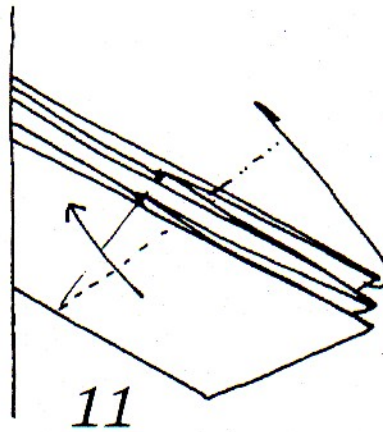

11

Adjust to form the Dove's wings.

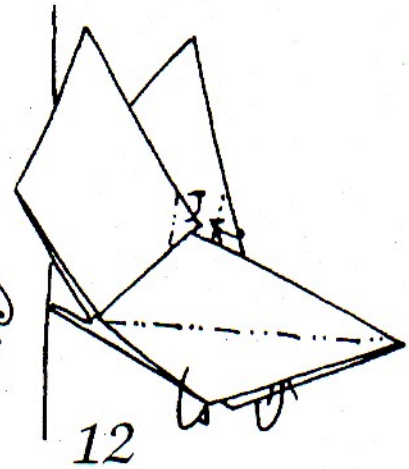

12

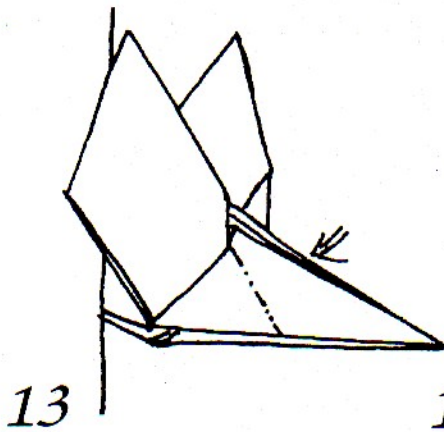

13

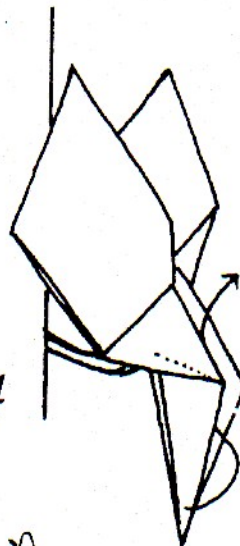

14

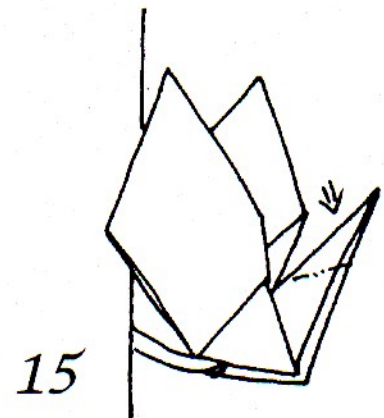

15

Refer to steps 7 to 10 of LOVE BIRDS for the formation of the Dove's head (Page 91).

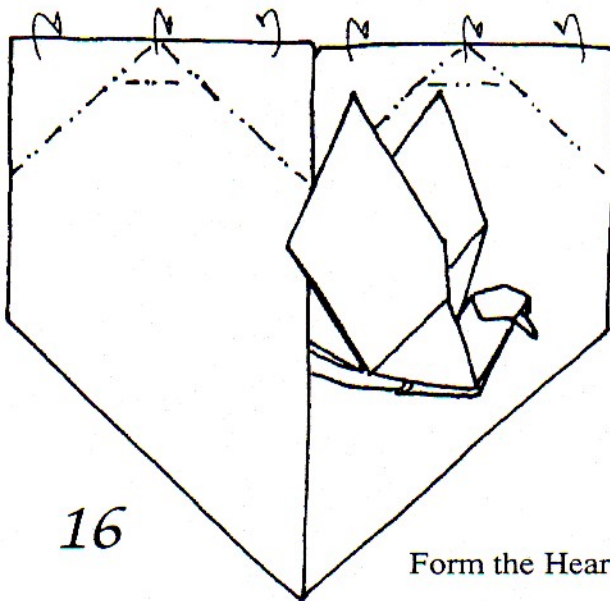

16

Form the Heart.

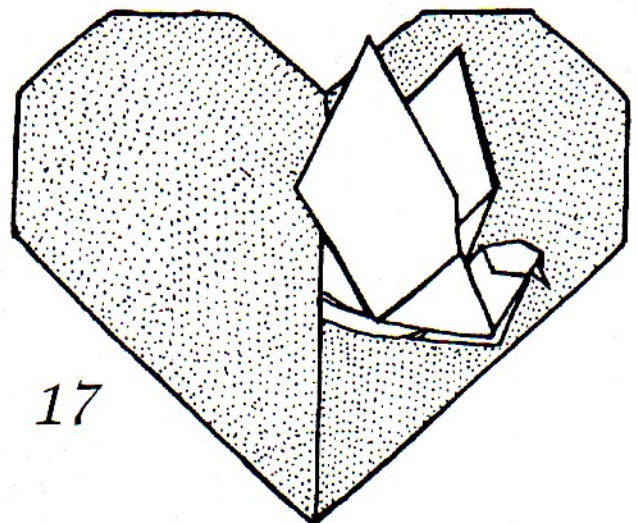

17

**Complete**  
See p.5, no.2

# Circle of Hearts [Modular]

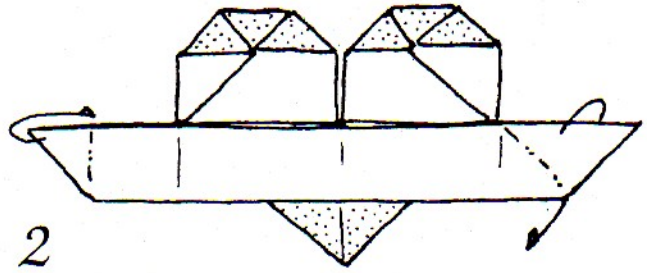
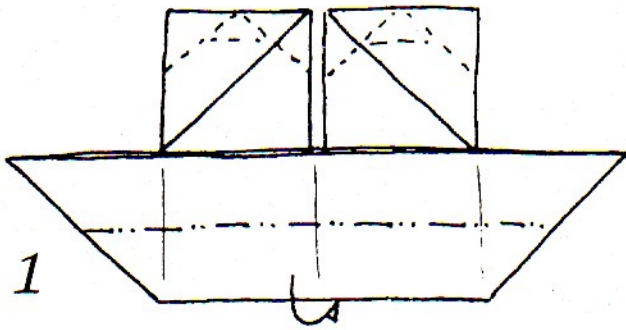

Step 6 of FLYING HEART (Page 89).

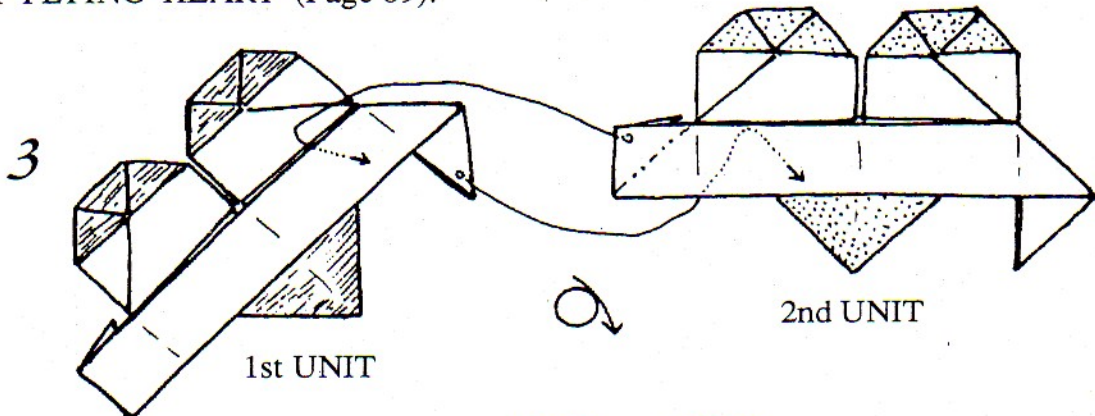

4  
Join 8 units  
to form a  
circle of Hearts.

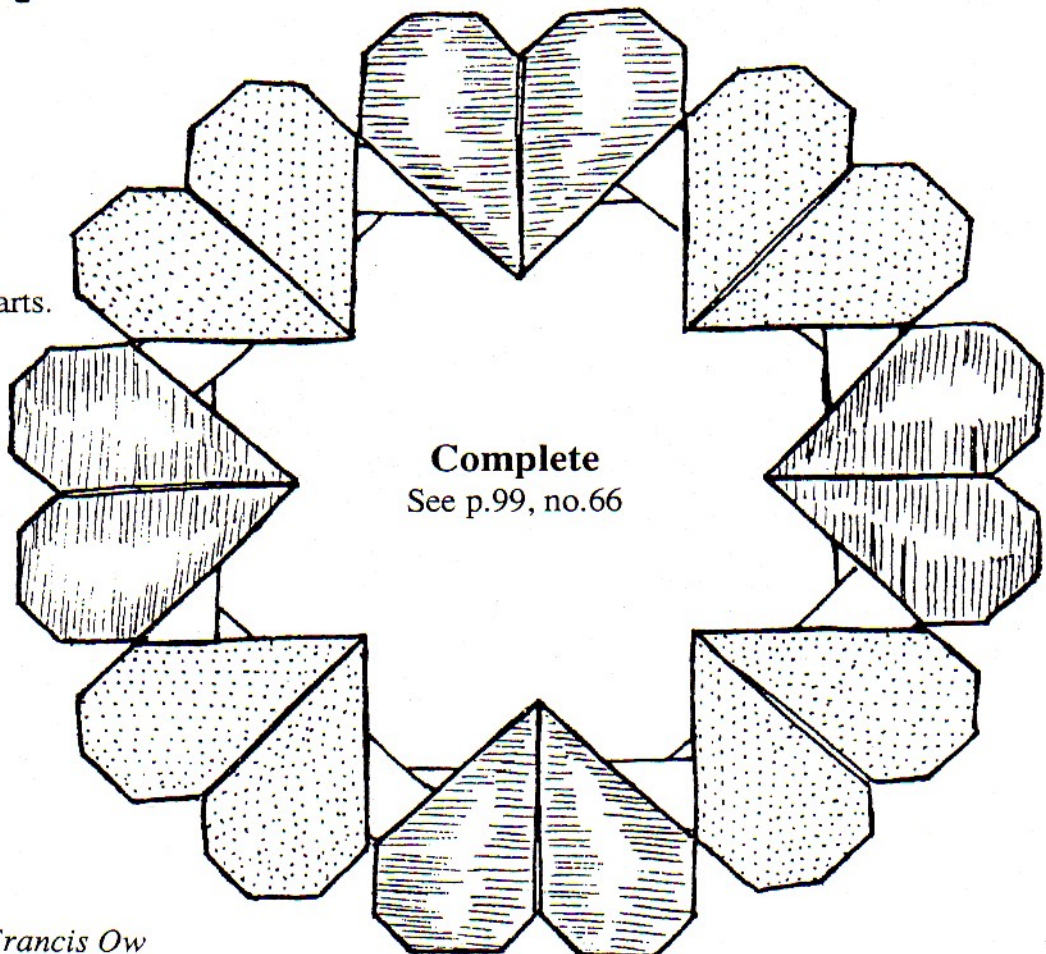

Model: Paul Ee  
Drawings and  
Modifications: Francis Ow



# Heart Ring 3 / Book Marker

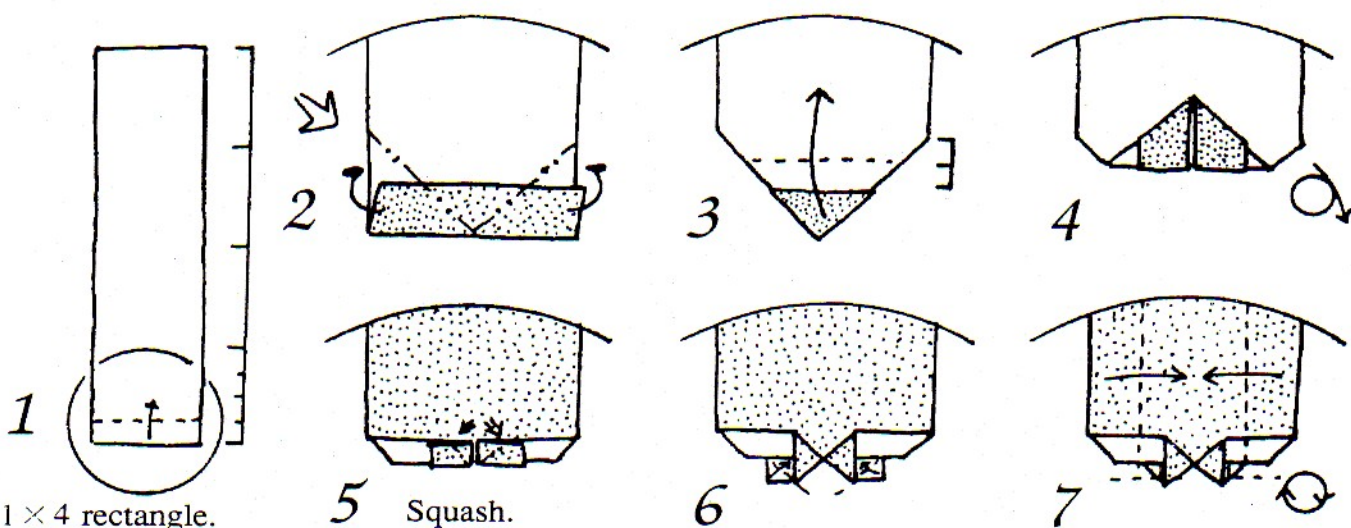

1 × 4 rectangle.  
White side up.

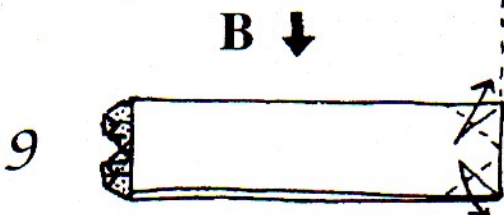
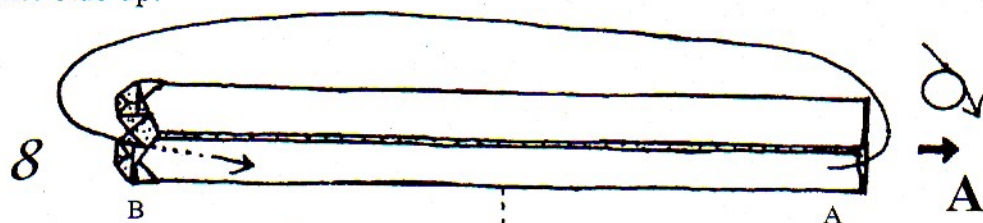

**RING 3 (A)**  
Insert to form a ring.  
Adjust to fit finger.

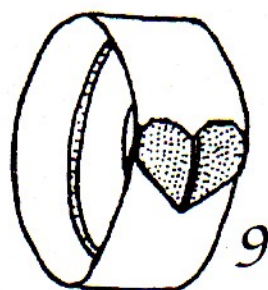

**Complete**  
See p. 7, no.12

**BOOK MARKER (B)**  
Fold A to B. (9) crease  
and unfold to step 7.

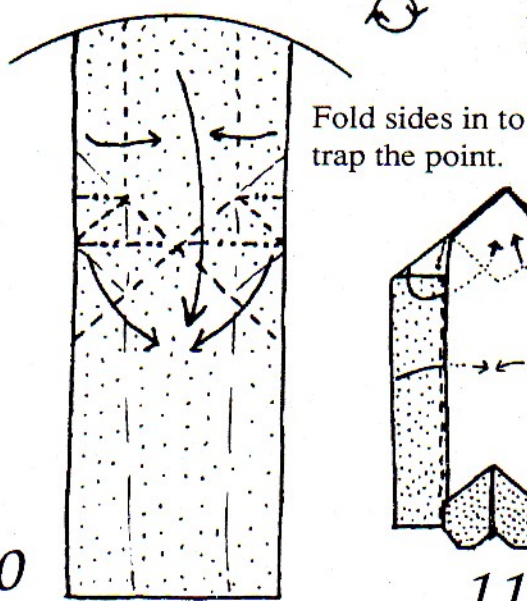

10  
Correct the creases  
and refold as shown.

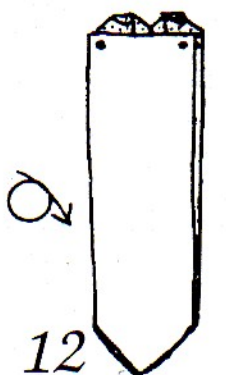
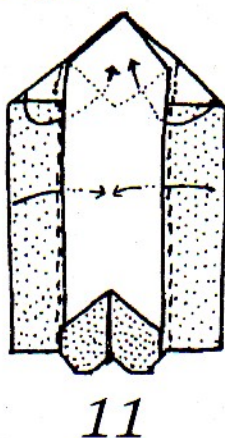

12  
Insert corners  
into the  
pockets below.

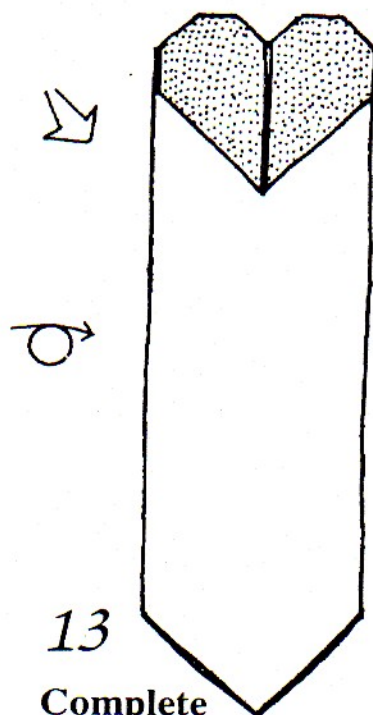

13  
**Complete**  
See p.9, no.21

# Heart Corner Marker

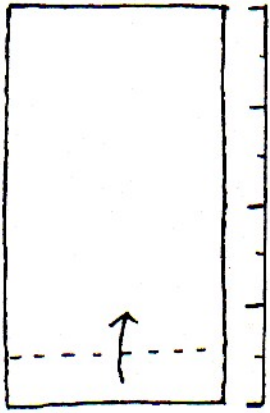

2

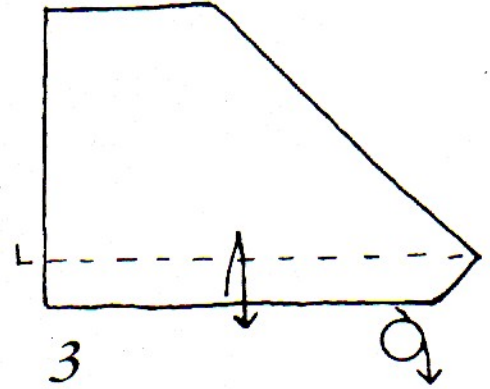
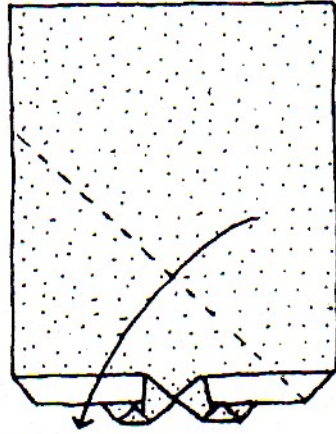

1 1 x 2 rectangle. White side up.  
Fold as in steps 2 to 7 of  
HEART RING 3 (Page 95).

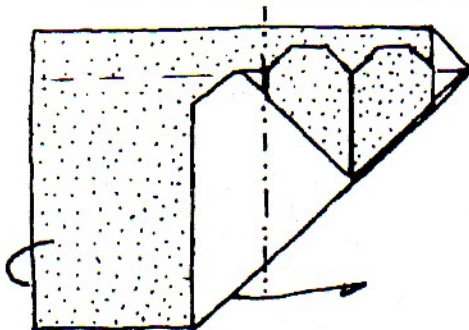

4

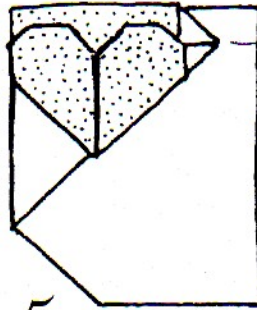

5

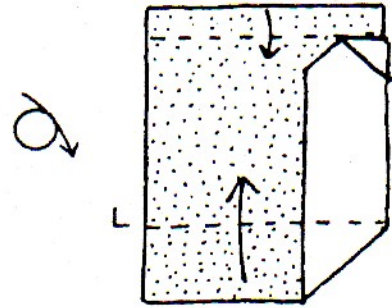

6

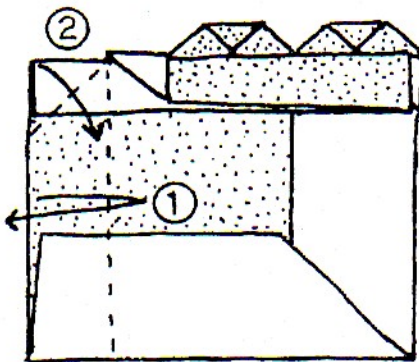

7

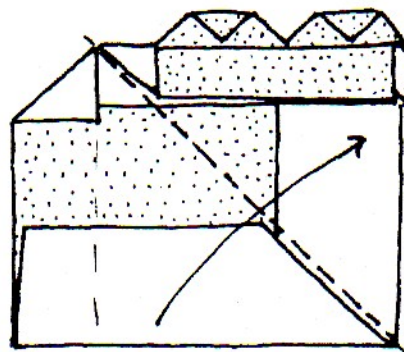

8

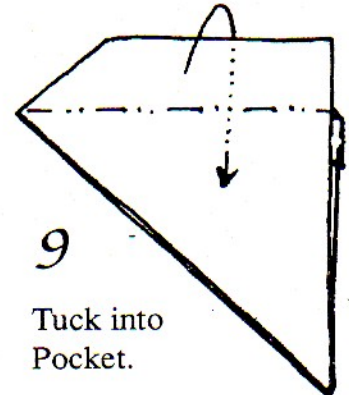

9

Tuck into  
Pocket.

Diagrams show model  
for top left corner  
of page. To make  
model for top right  
corner, fold from  
the mirror images  
of the diagrams.

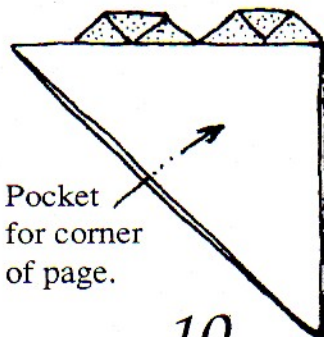

Pocket  
for corner  
of page.

10

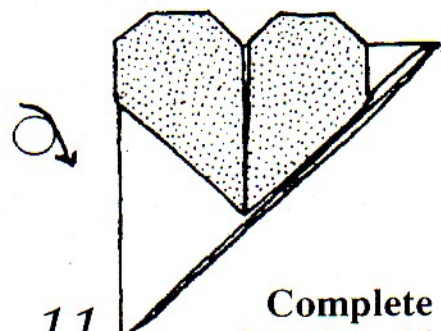

11

**Complete**  
See p.8, no.16

# Heart Corner Marker 2

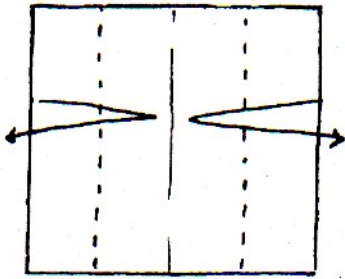

1 White side up.

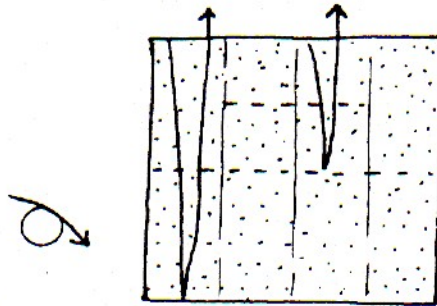

2

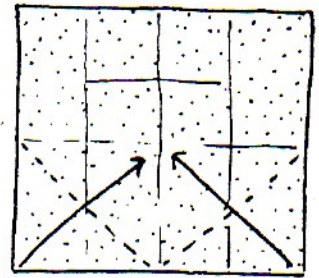

3

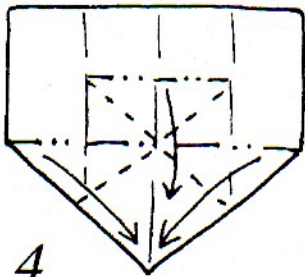

4

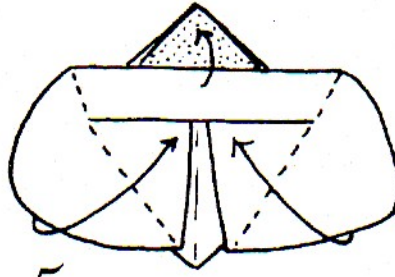

5

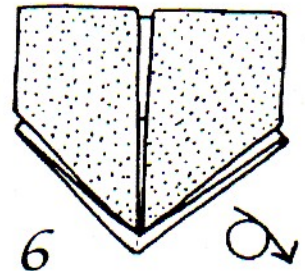

6

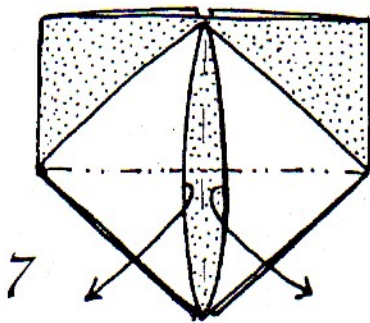

7

Open and flatten.

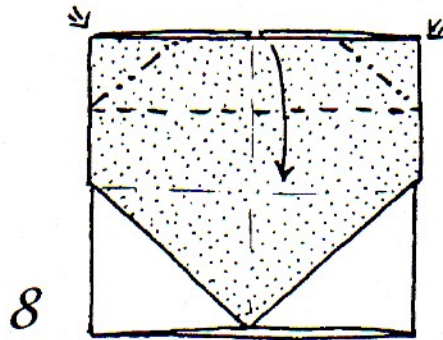

8

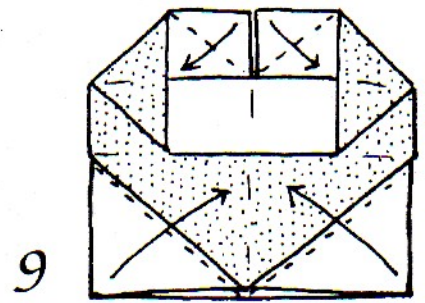

9

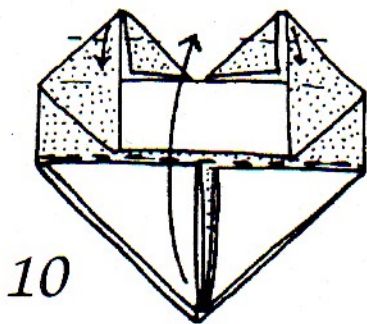

10

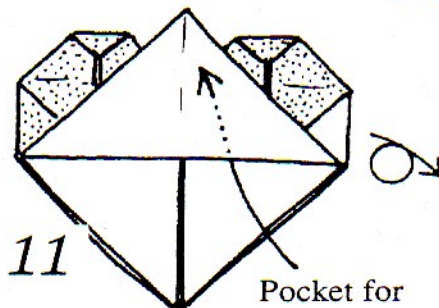

11

Pocket for  
paper corner.

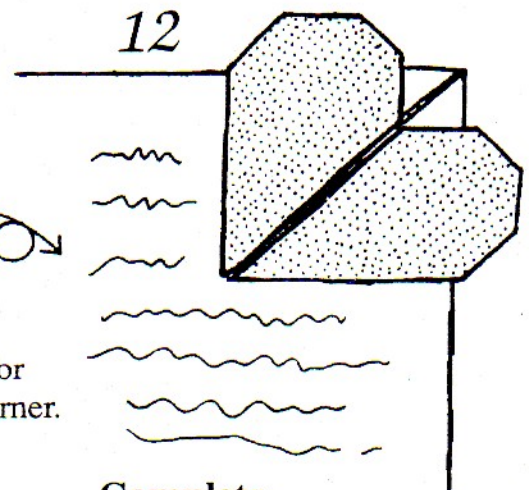

12

**Complete**  
See p.8, no.15

# Twin Hearts with Stand

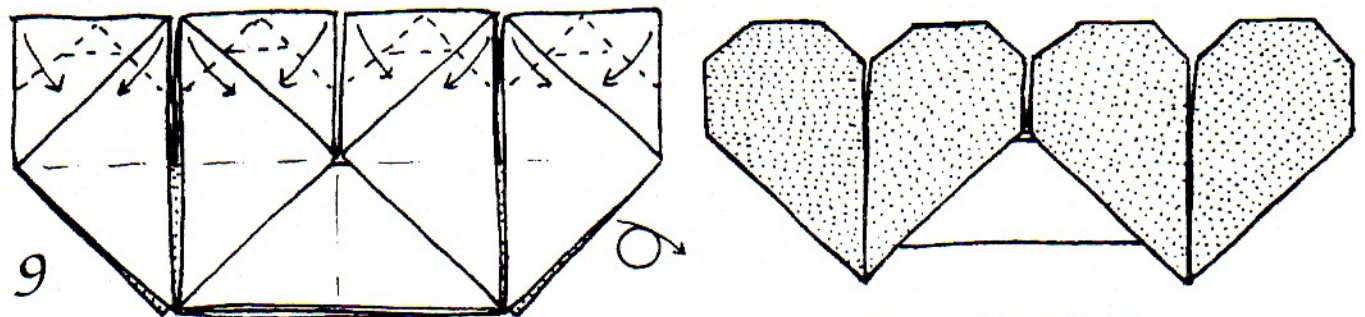
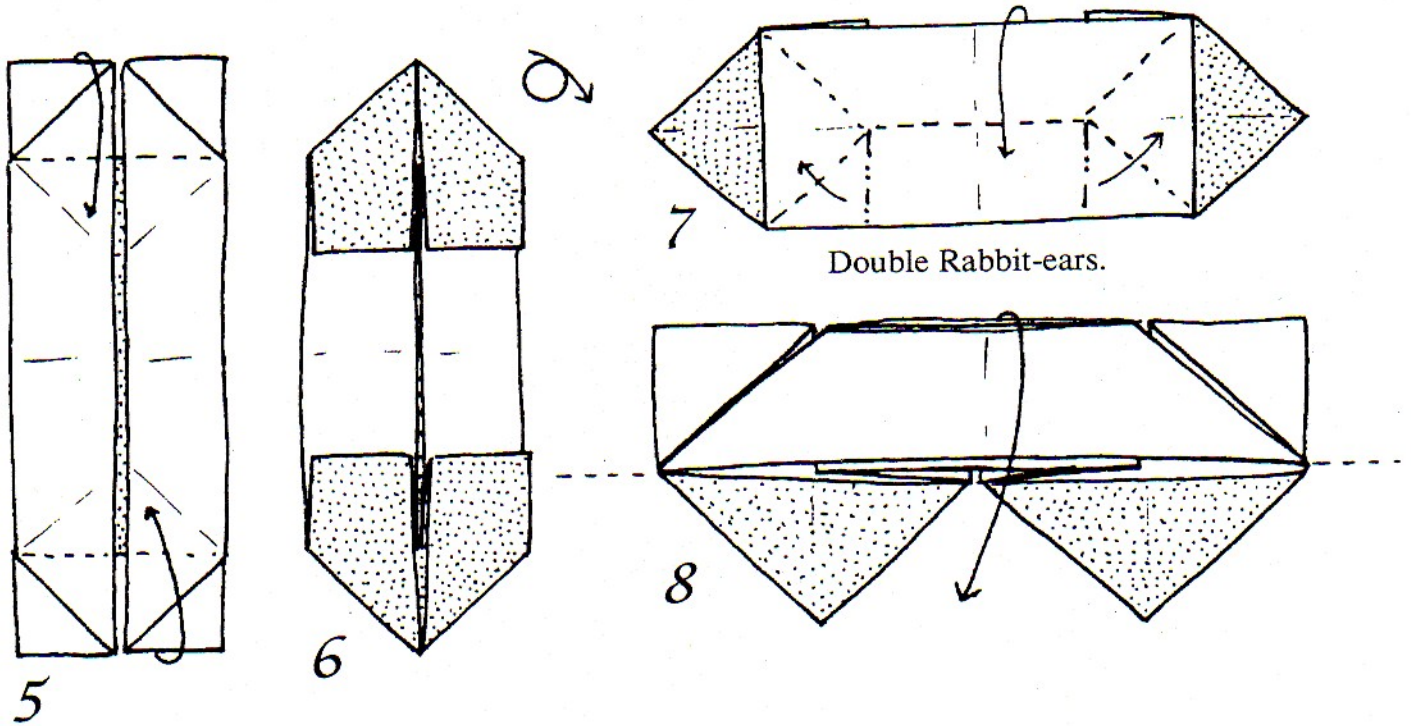
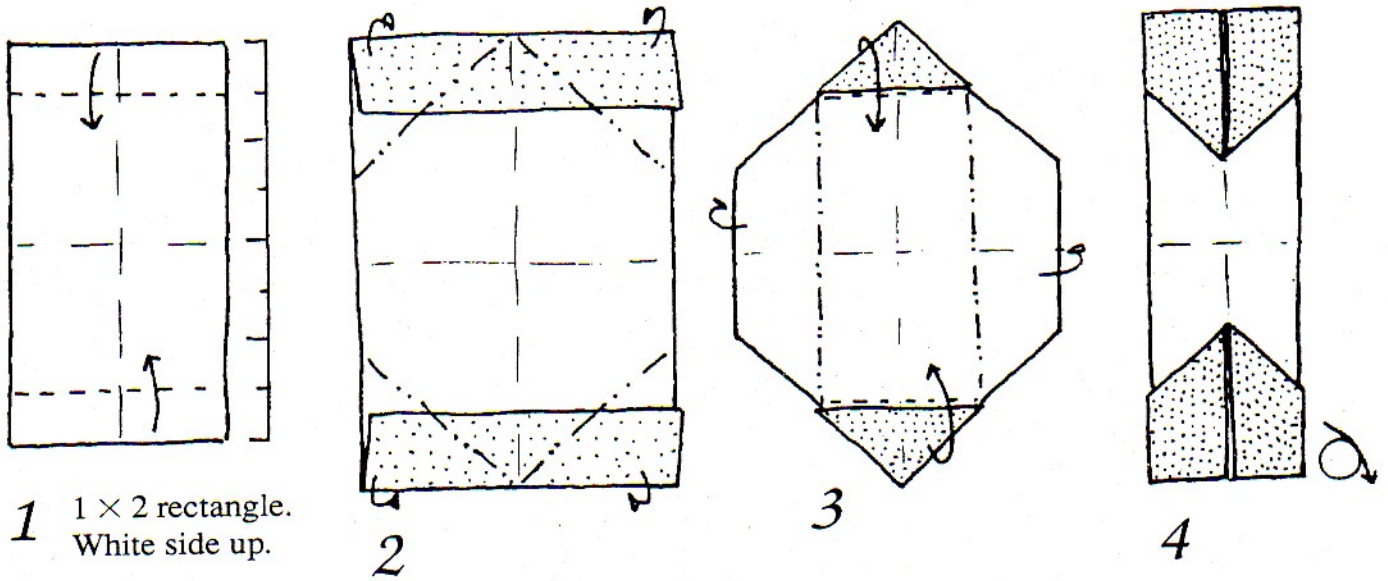

Shape both hearts. Refer to steps 7 to 9 of FLYING HEART (Page 89).

See p.99, no.65  
or See p.10, no.27



62

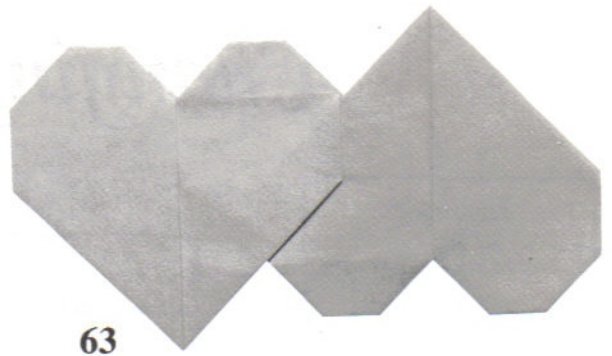

63



64

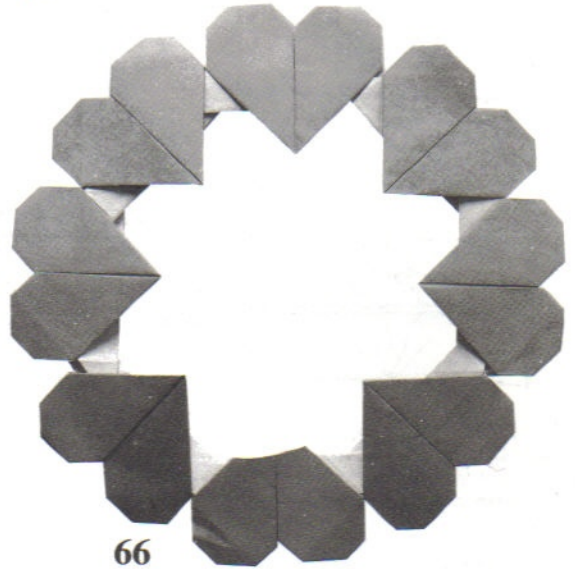

66

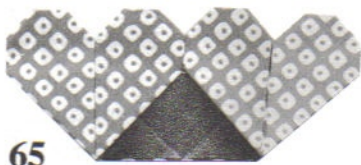

65

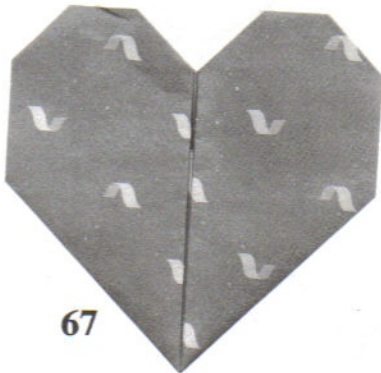

67



68



69

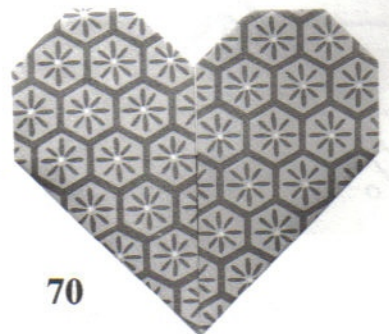

70

# Changing Heart

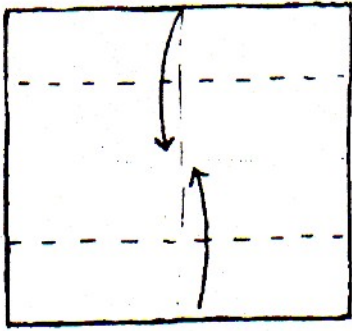

1 White side up.

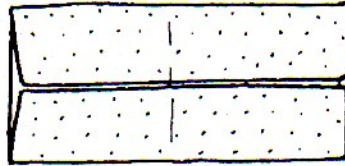

2

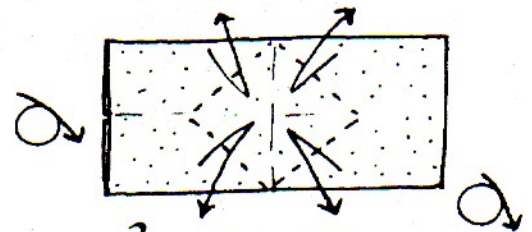

3 Pre-crease.

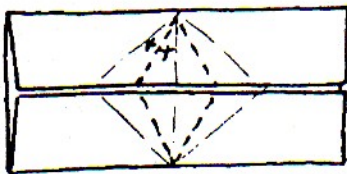

4 Pre-crease.

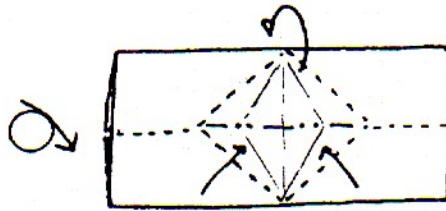

5

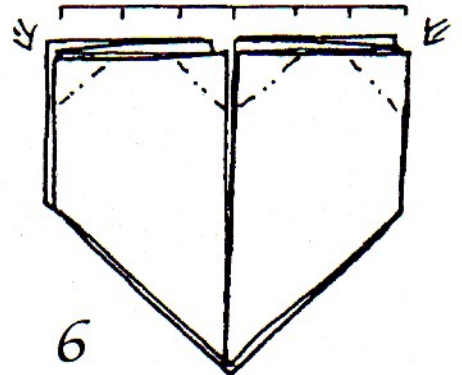

6 Sink or reverse-fold to shape the heart.

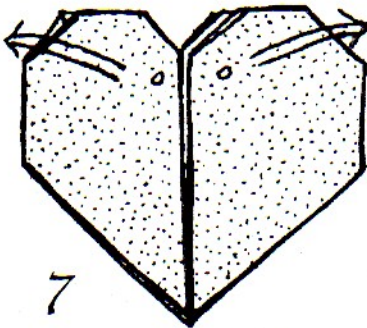

7 Hold ○○ and pull apart.

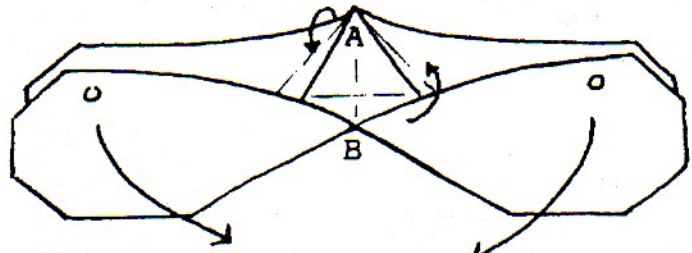

8 Bring points A and B together, ...

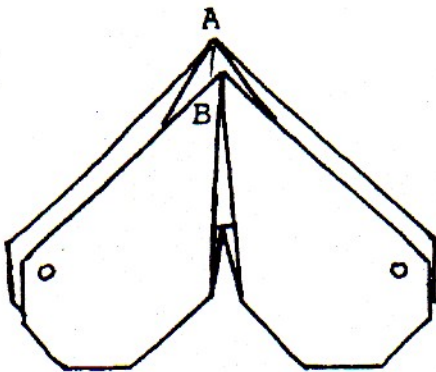

9 ... turn top-side down to form ...

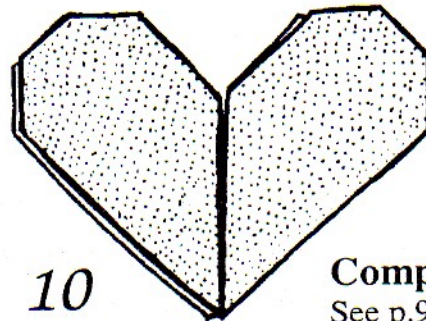

10

Complete  
See p.99, no.67

... another Heart shape.

# Heart Tangram

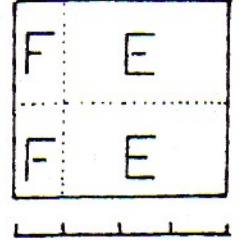
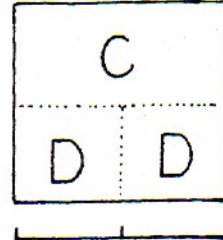
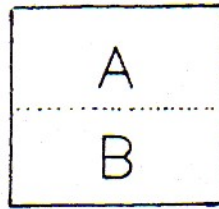
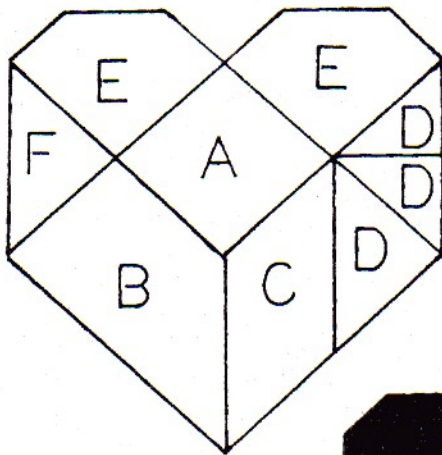

**Complete**  
See p.9, no.19



The above diagrams show the dimensions used for each part. Make all the parts as shown and reform it to the shaded Heart. (All the 9 parts must be used)

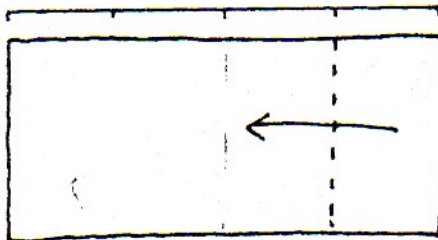

1 White side up.

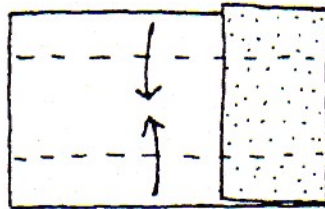

2



3

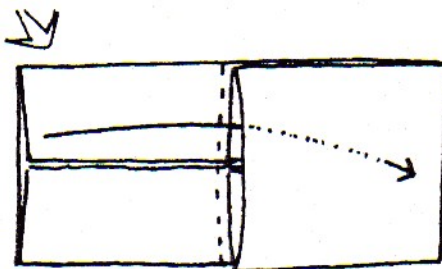

4 Tuck in.

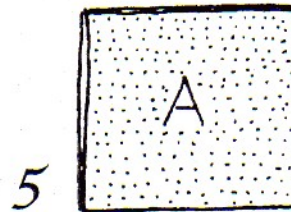

5

**Part A** Complete

**NOTE**  
Besides just Hearts, this Tangram Set can also be used to make many other different shapes. Try it out and have fun with it !

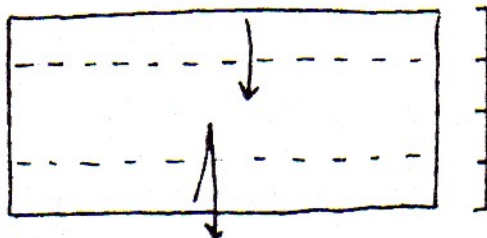

1 White side up.

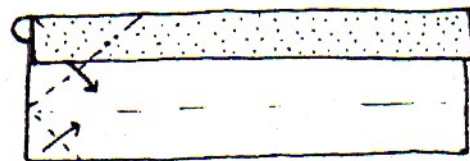

2

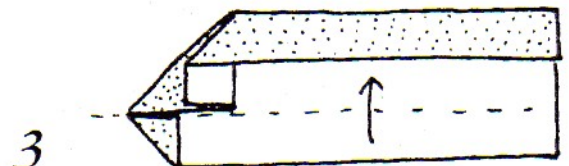

3

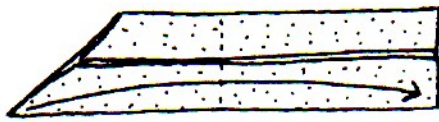

4

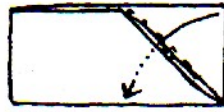

5 Tuck in.

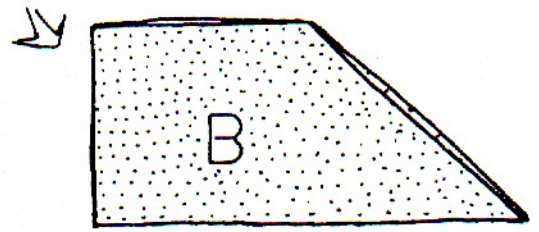

6 Part B Complete

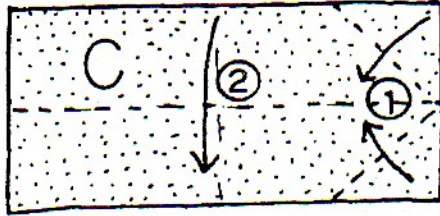

1 Color side up.

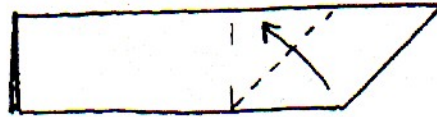

2

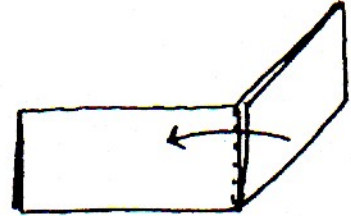

3

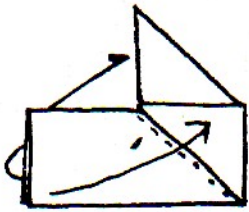

4 Color change.

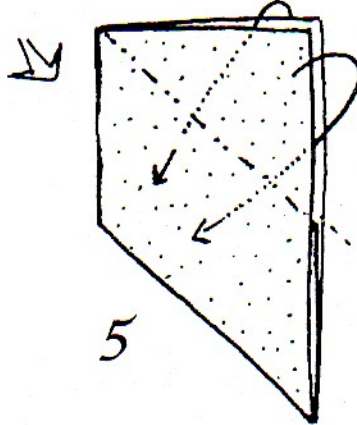

5

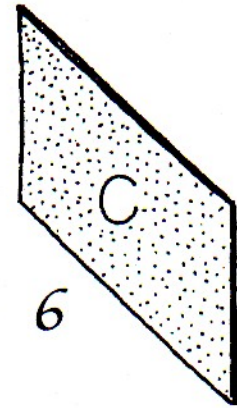

6

Part C Complete

Tuck the 2 flaps into the pocket.

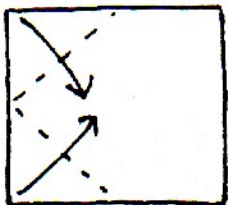

1 White side up.

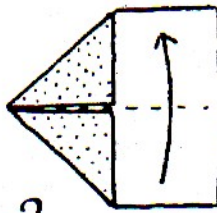

2



3

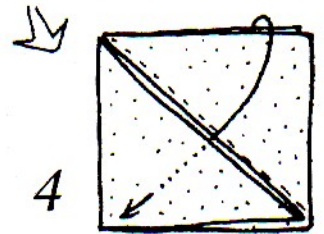

4

Tuck in.

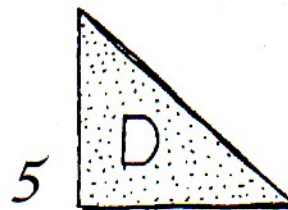

5

Part D Complete  
Make one more.



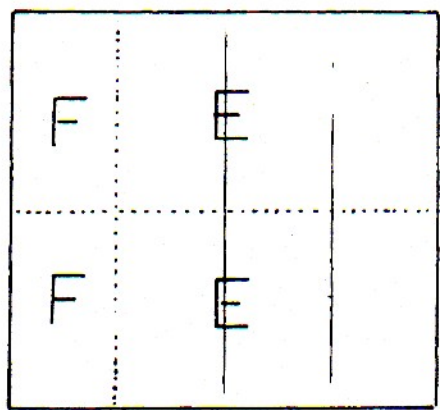

Pre-crease into 4ths.  
and cut as shown.

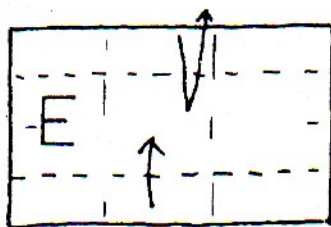

1

White side up.

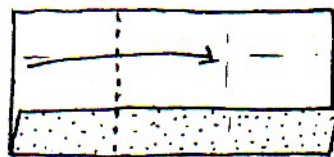

2

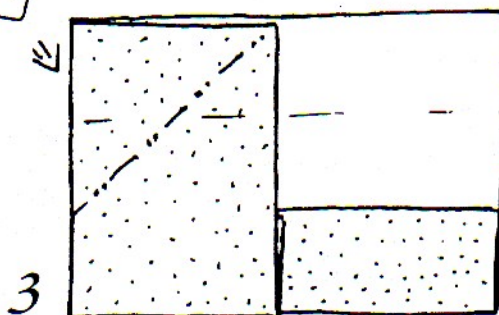

3

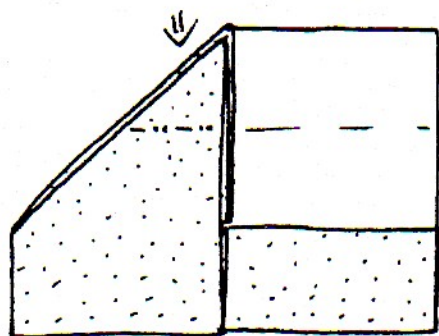

4

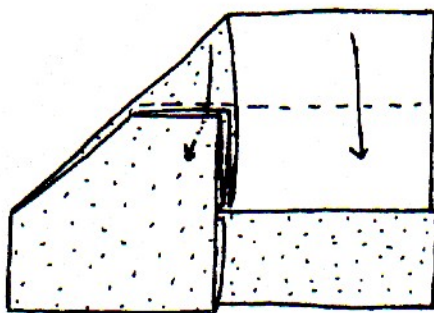

5

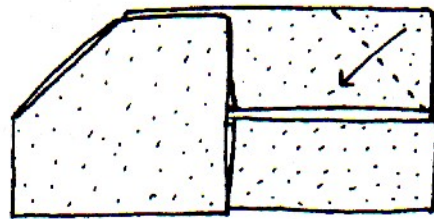

6

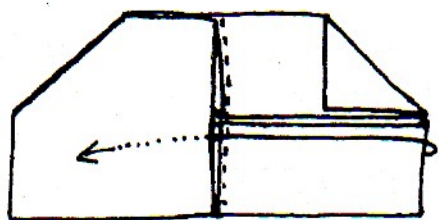

Tuck in.

7

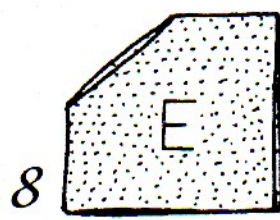

8

**Part E Complete**  
Make one more.



1 White side up.

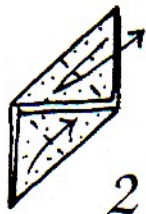

2

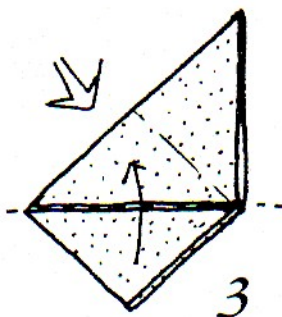

3

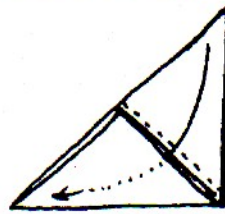

4 Tuck in.

5



**Part F Complete** Make one more.

# Love is Blind

To make the model large enough to wear,  
use a 50mm × 600 mm (2" × 23 1/2") rectangle.



1 12 × 1 rectangle.  
White side up.

- (1) Crease off 2 square sections from the closed edge.
- (2) Mark off 1/4 of the first section from the closed edge.
- (3) Unfold with the color side up.

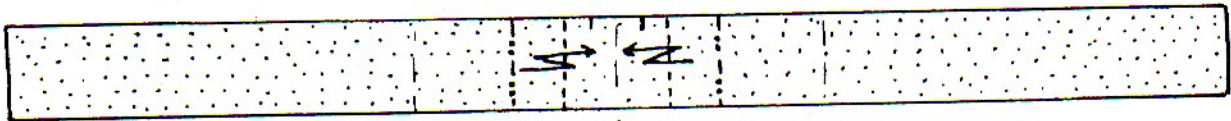
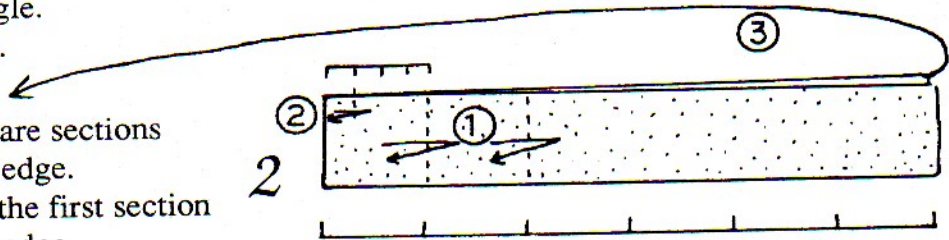

3 Make 2 pleats. Note the location points.

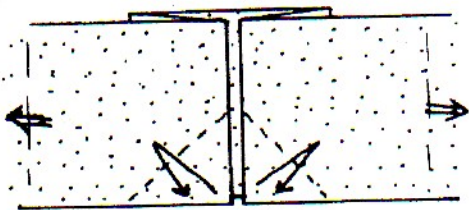

4 Pre-crease and return to step 3.

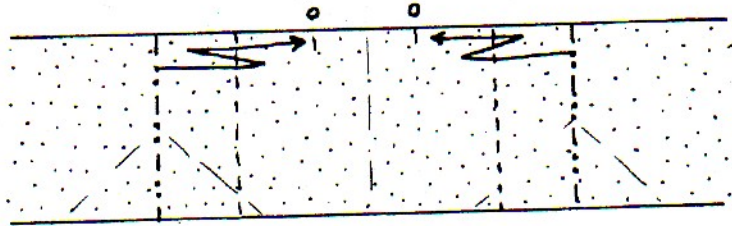

5 Fold each mountain crease line to the nearest mark made in step 2 (2).

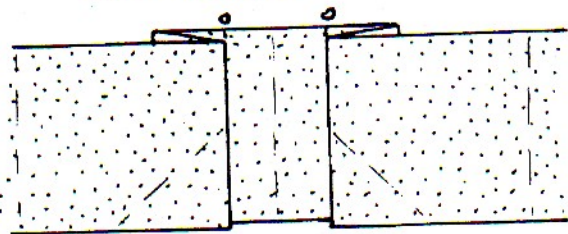

6

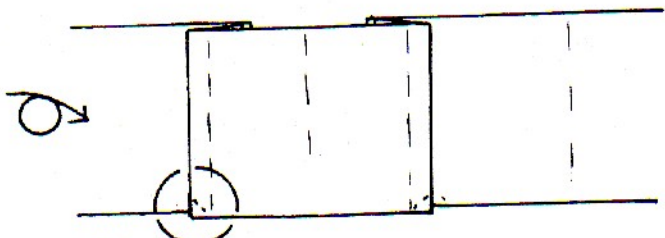

7

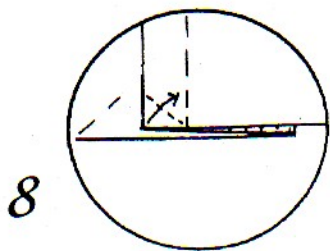

8

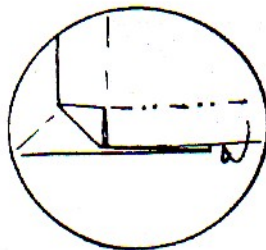

9

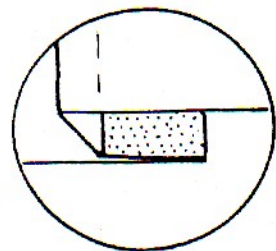

10

SECTION ENLARGED. Repeat steps 8 to 10 for the right side.

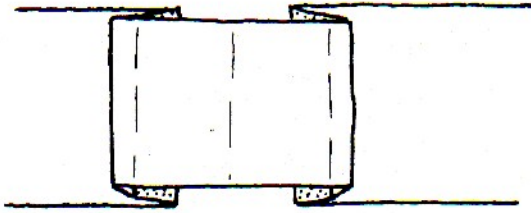

11

↻

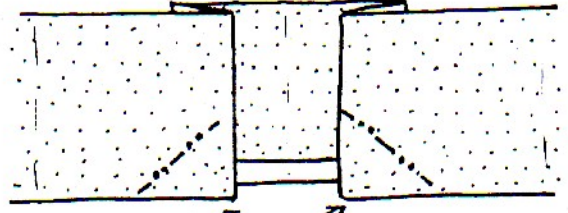

12 Reverse-folds.

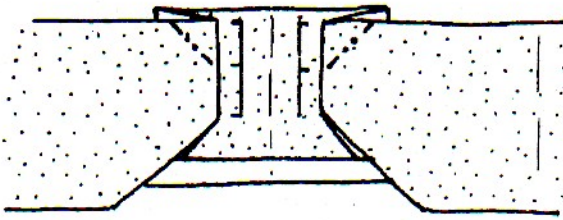

13 Reverse-folds.  
Note location points.

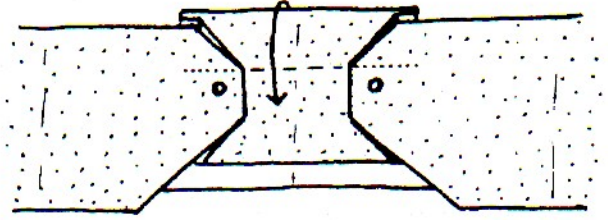

14 Lift up ○ ○ and  
fold down the top.

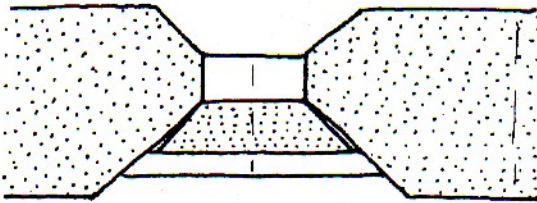

15

↻

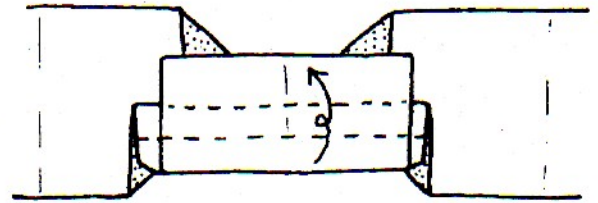

16

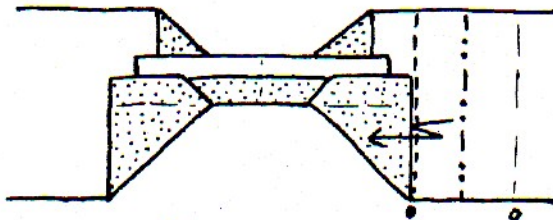

17 Pleat.  
Note location points.

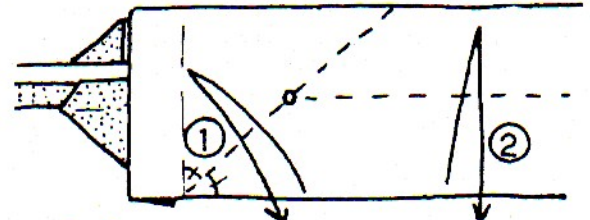

18 1. Pre-crease.  
2. Add in the middle crease line.  
Do not crease beyond ○.



19 Fold on the location point ○.

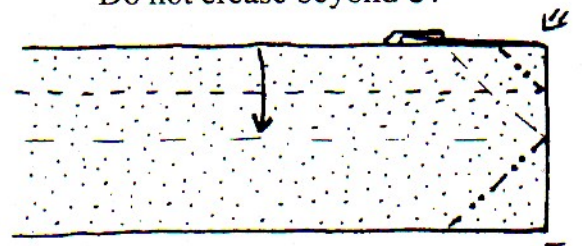

20

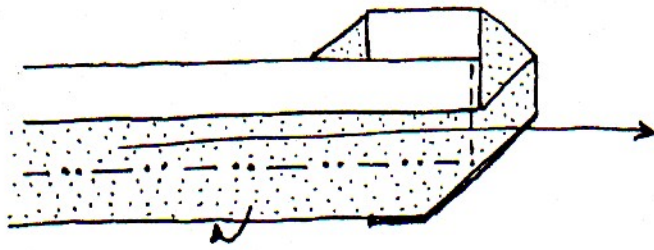

21

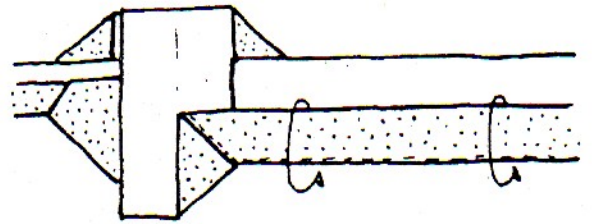

22

Color change.

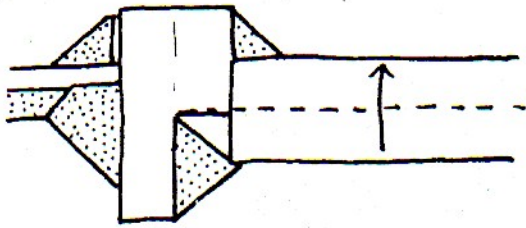

23

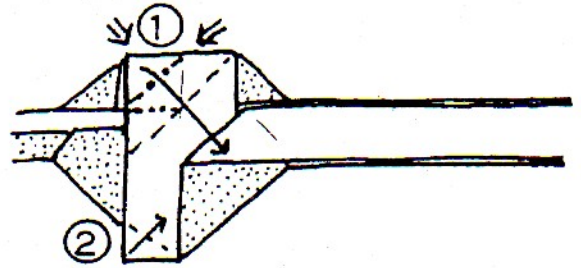

24

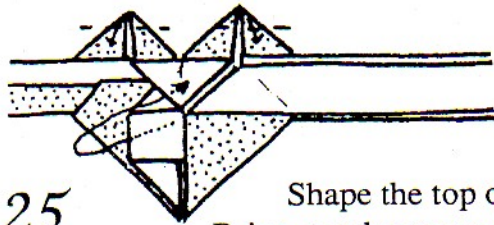

25

Shape the top of the heart.  
Bring out the paper from below  
and insert it below the small triangle.

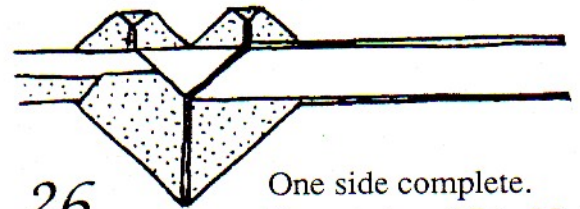

26

One side complete.  
Repeat steps 17 to 25  
for the other side.

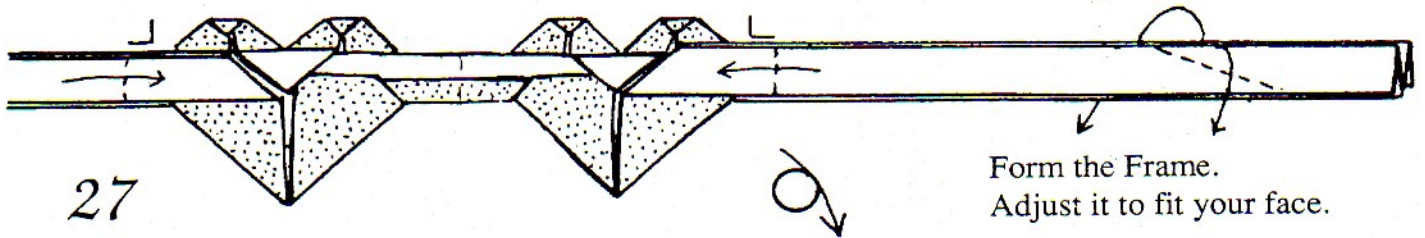

27

Form the Frame.  
Adjust it to fit your face.

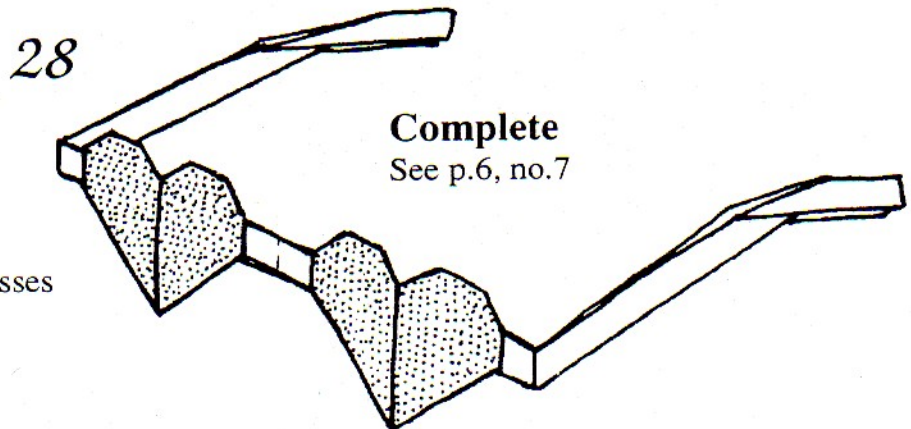

28

Complete  
See p.6, no.7

Love is blind.  
Put on these glasses  
to confirm.

# Broken Hearted

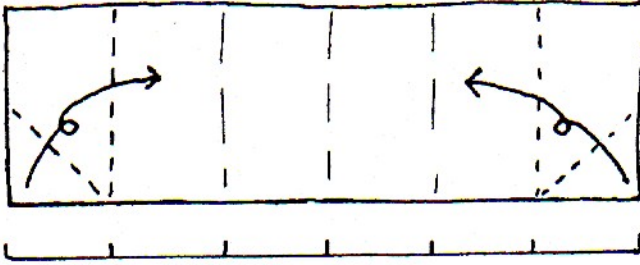

1 3 × 1 rectangle. White side up.  
Pre-crease vertically into 6ths and fold as shown.

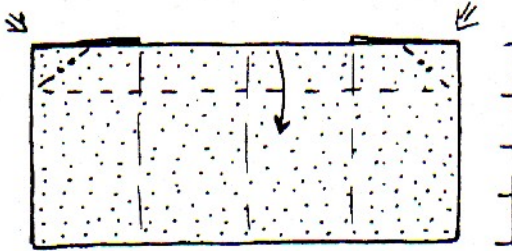
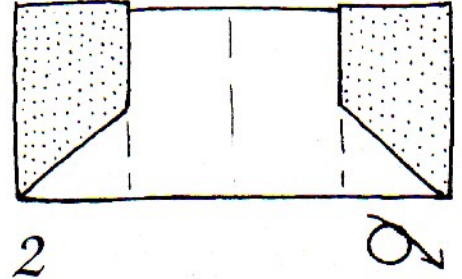

3

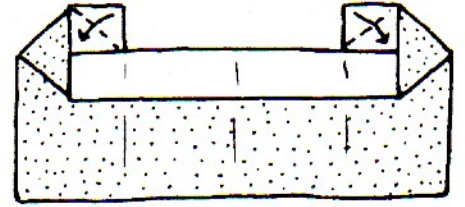

4

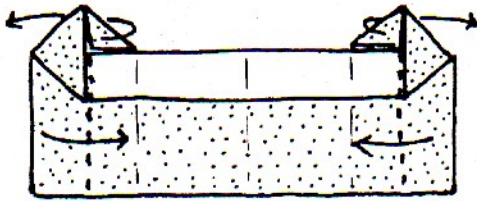

5

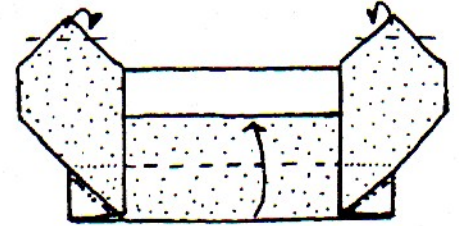

6

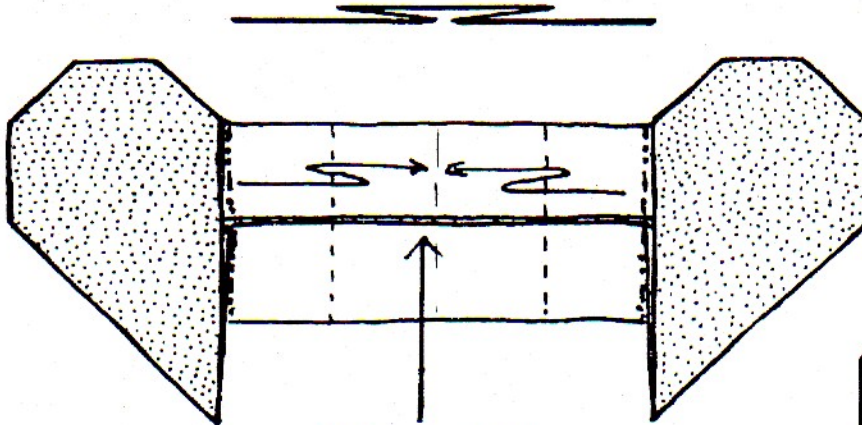

7

Write your love message here.

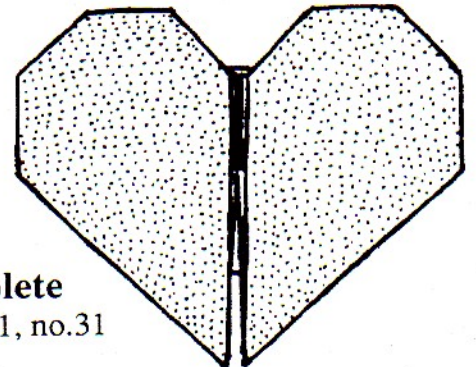

8

**Complete**  
See p.11, no.31

# 3-D Heart (Corrie's)

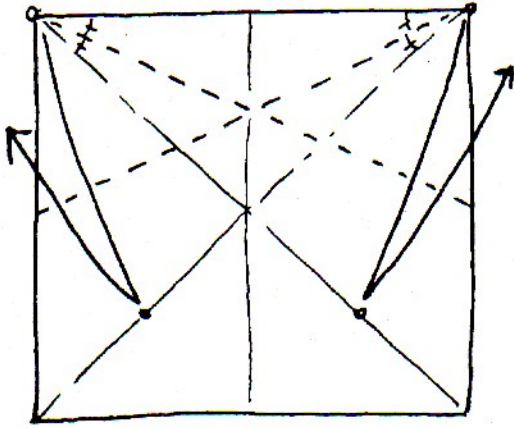

1 White side up.

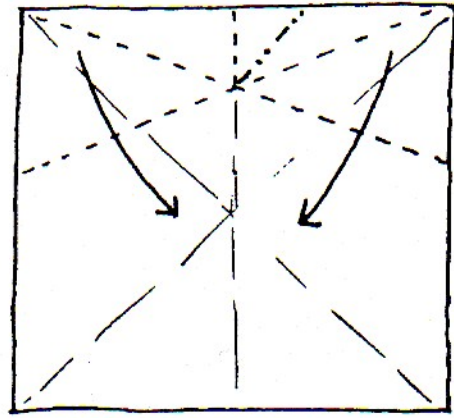

2 Rabbit-ear.

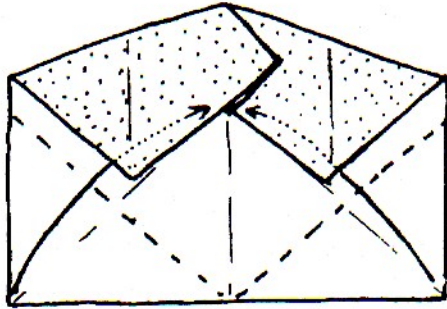

3

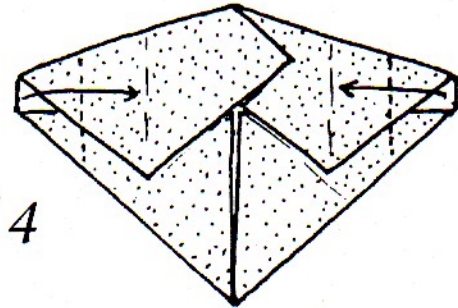

4

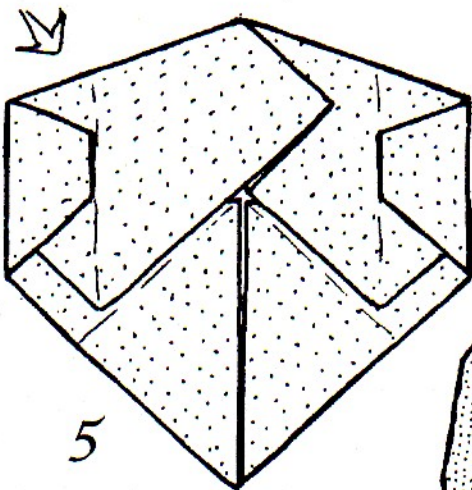

5

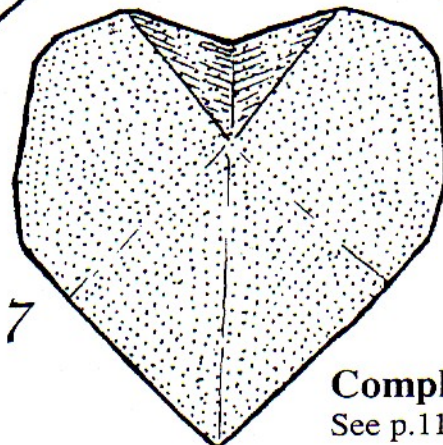

7

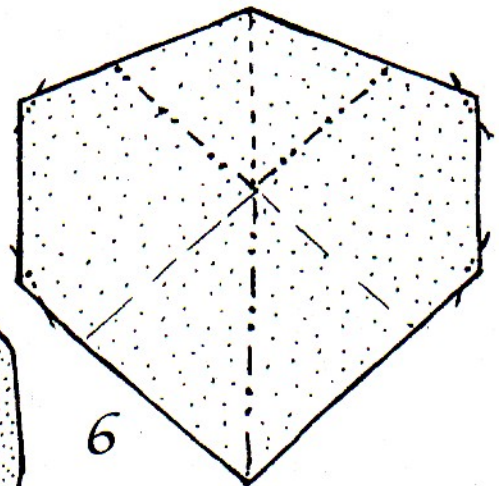

6

Round off the corners and 3-D along the creases.

**Complete**  
See p.11, no.33

Model: Edwin Corrie.  
Drawings: Francis Ow.

# Heart 2

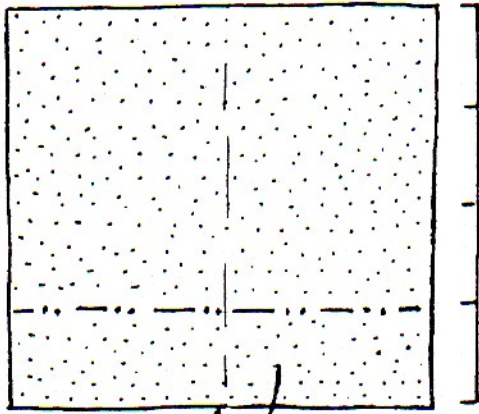

1 Color side up.

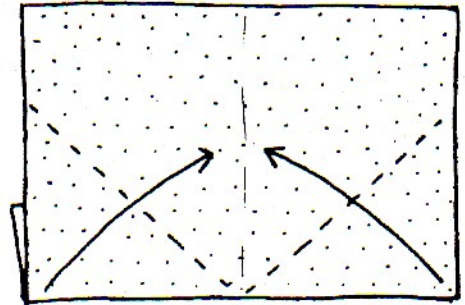

2

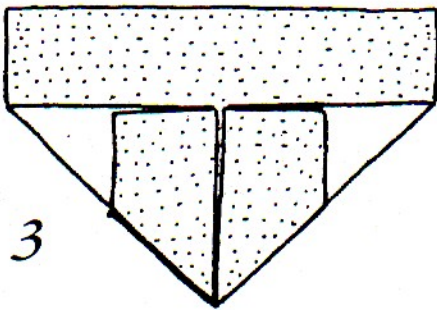

3

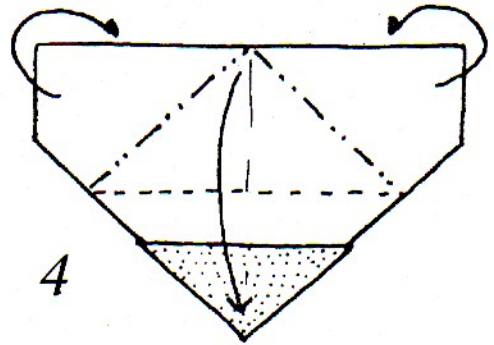

4

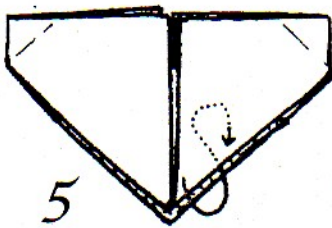

5

Tuck into the pocket.

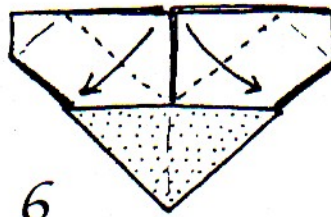

6

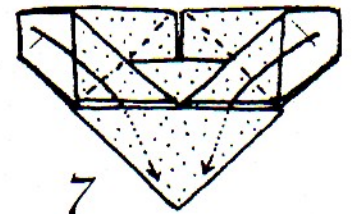

7

Tuck into the pocket.

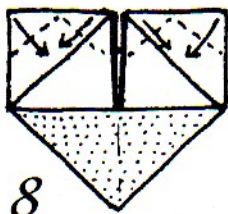

8

Insert your message here.

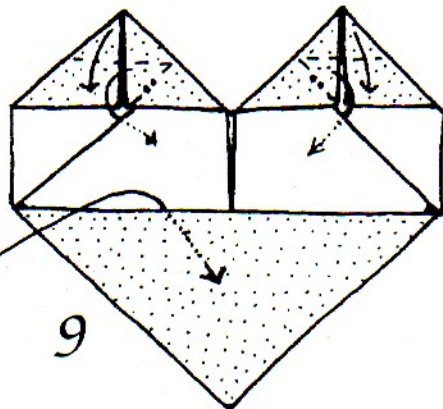

9

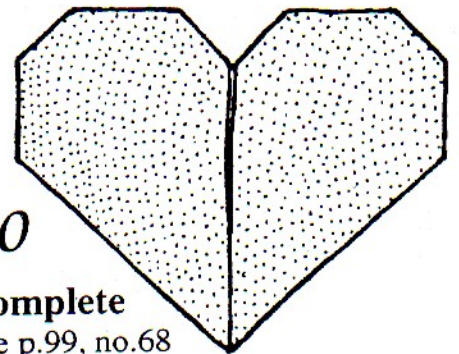

10

Complete  
See p.99, no.68

# Heart 3

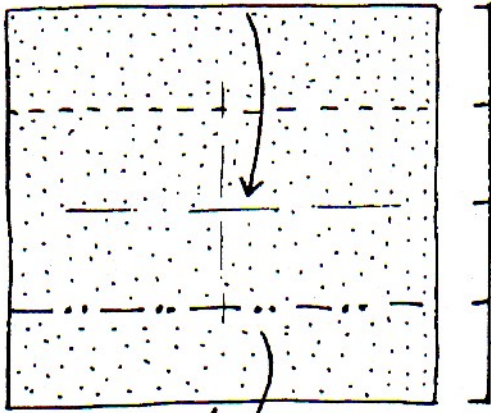

1 Color side up.

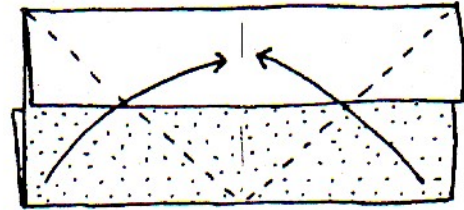

2

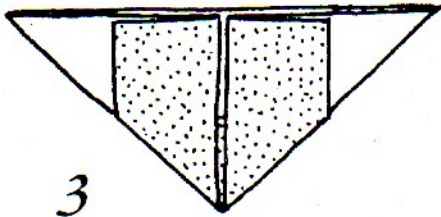

3

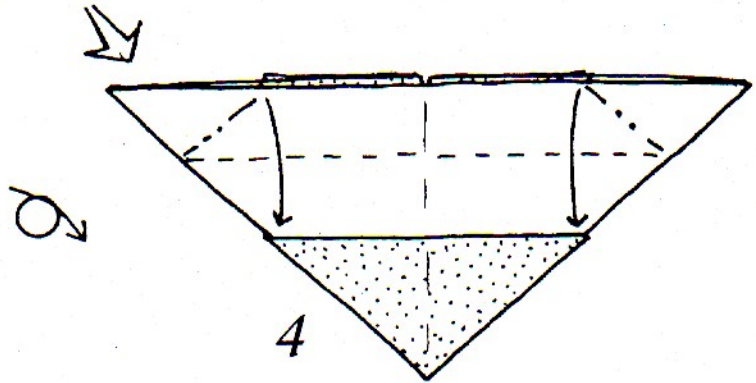

4

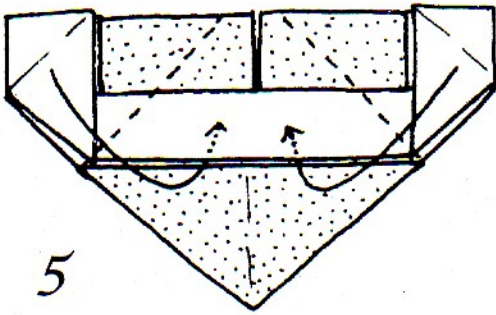

5

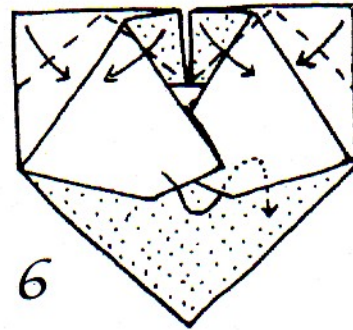

6

Tuck into the pocket.

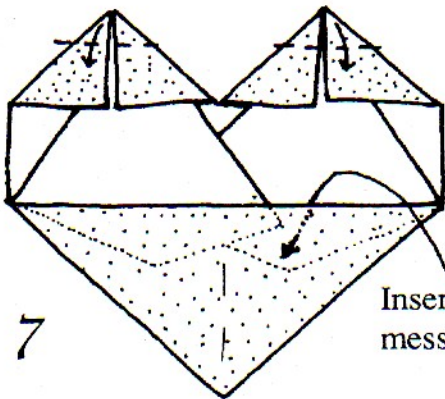

7

Insert your message here.

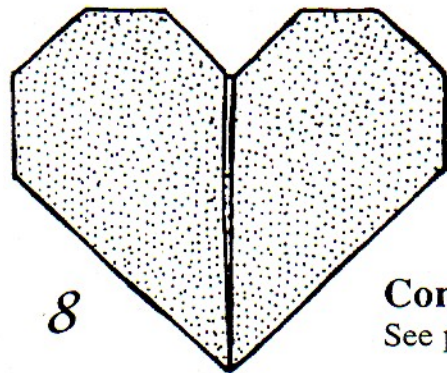

8

**Complete**  
See p.99, no.70

Model: Edwin Corrie / Drawings: Francis Ow



# House of Love

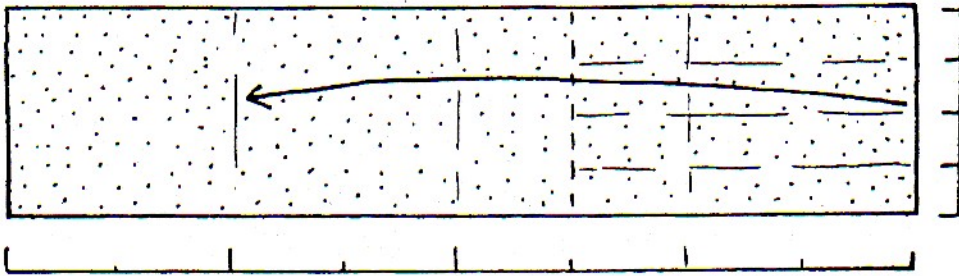

1

4 × 1 rectangle. Color side up.  
Pre-crease and fold as shown.  
Note position of location point.

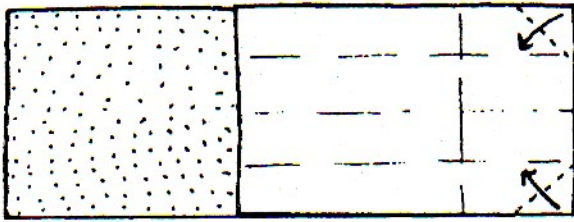

2

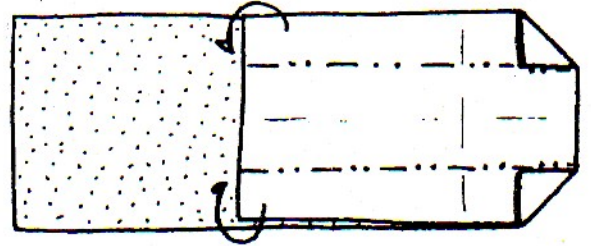

3

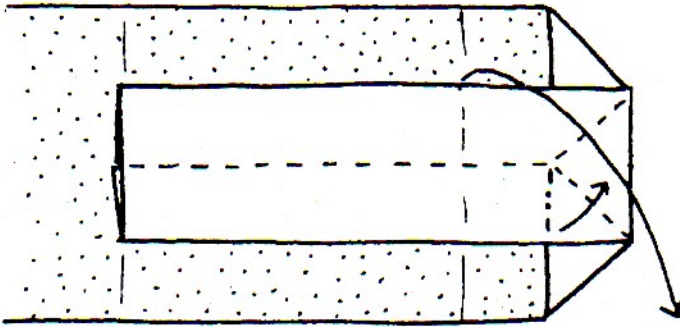

4

Rabbit-ear.

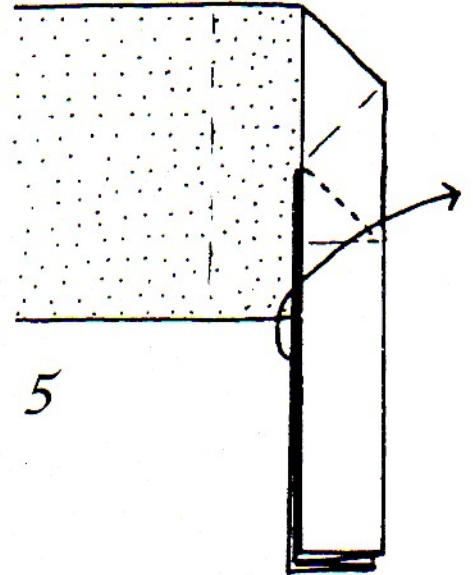

5

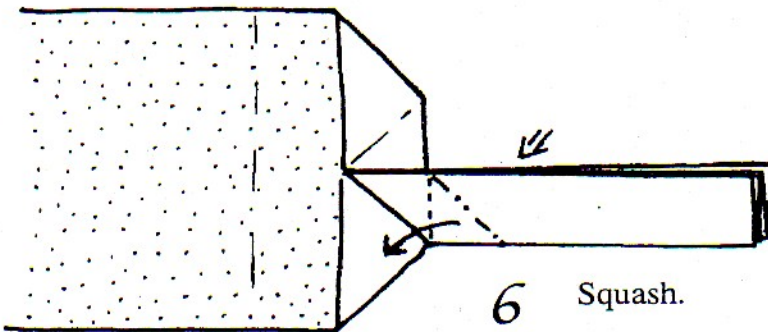

6

Squash.

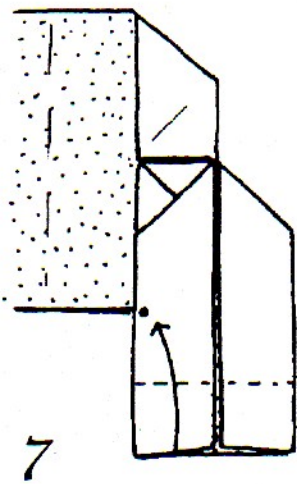

8

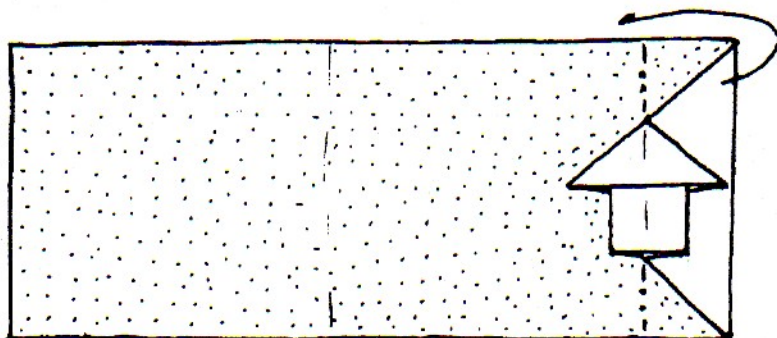
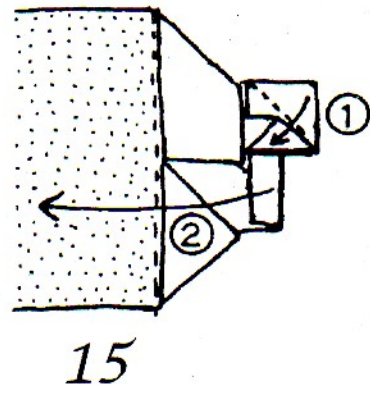
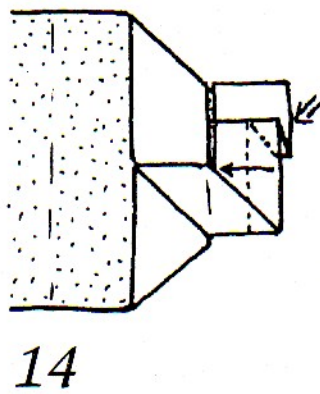
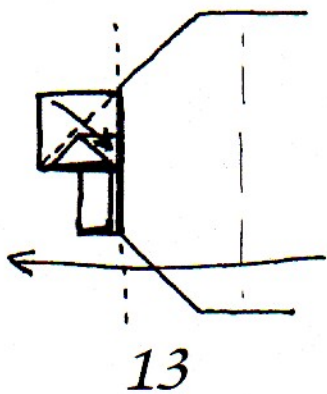
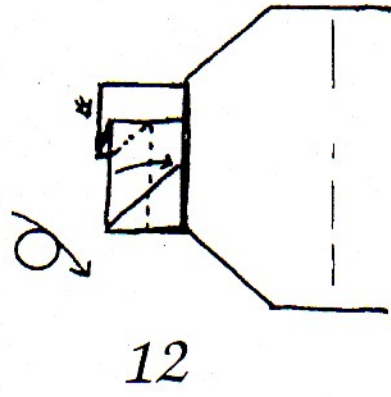
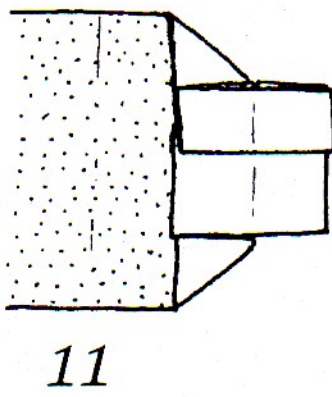
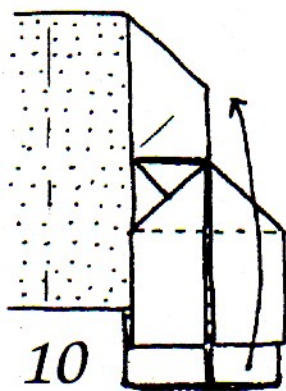
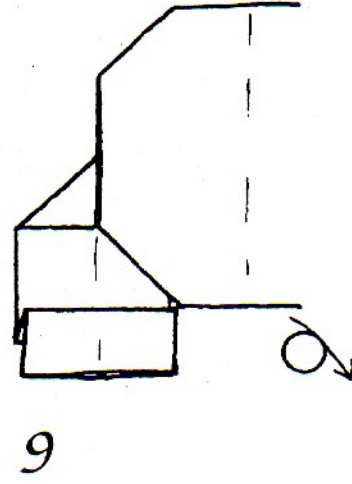
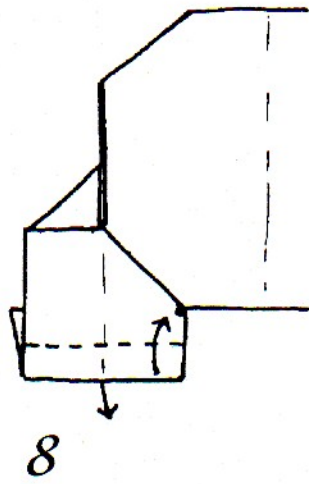

16

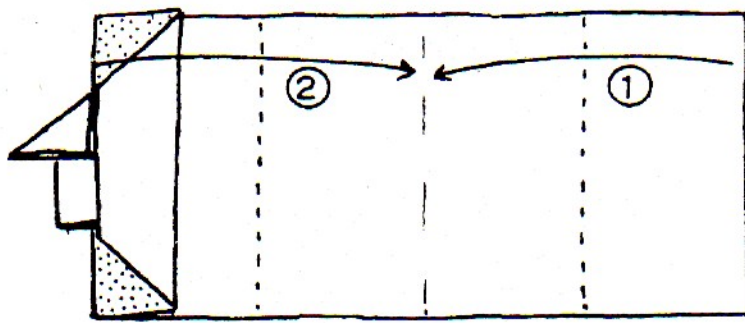

17

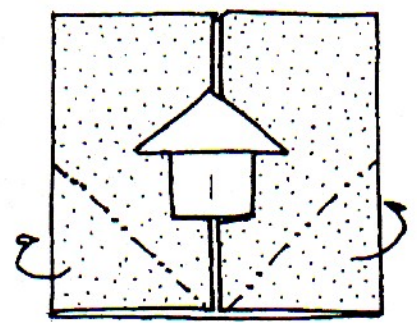

18

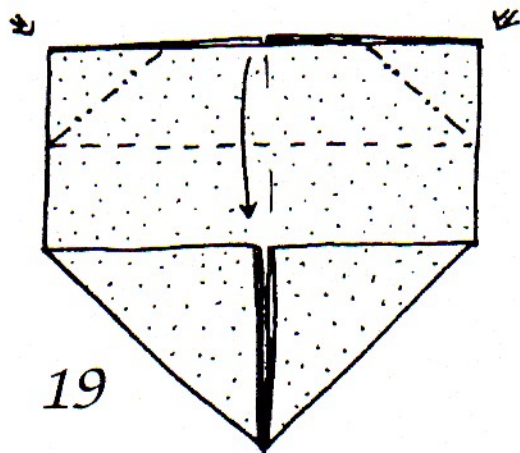

19

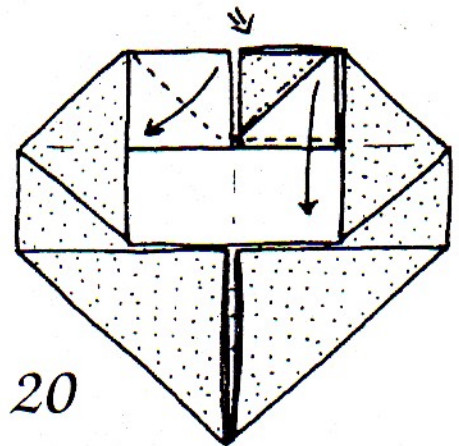

20

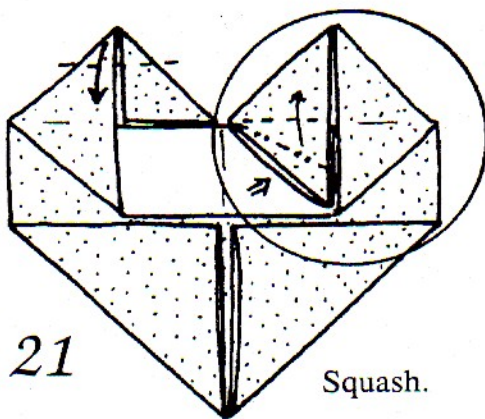

21

Squash.

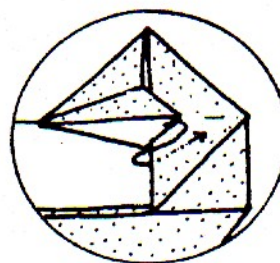

22

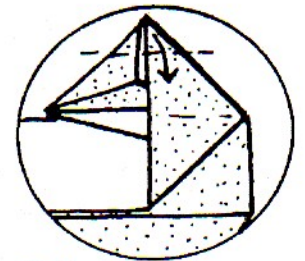

23

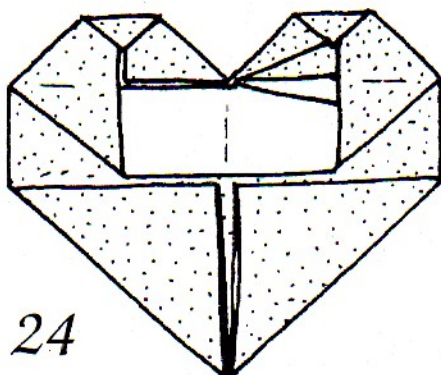

24

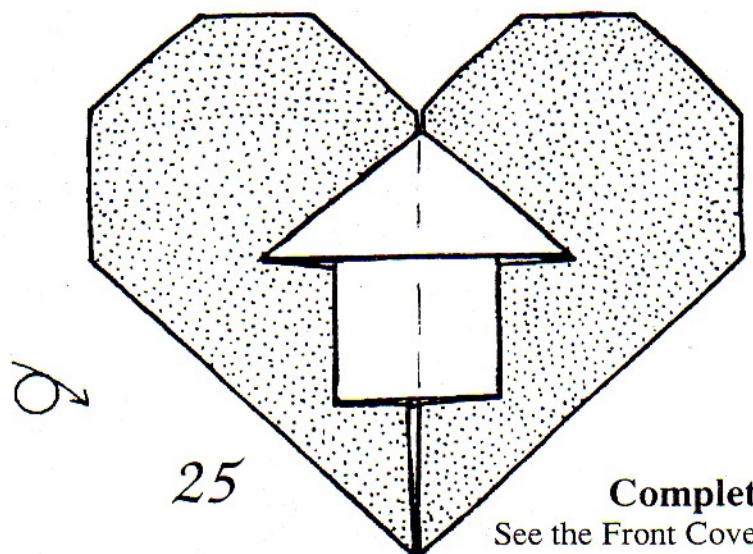

25

Complete  
See the Front Cover.

# "O"-Hearted

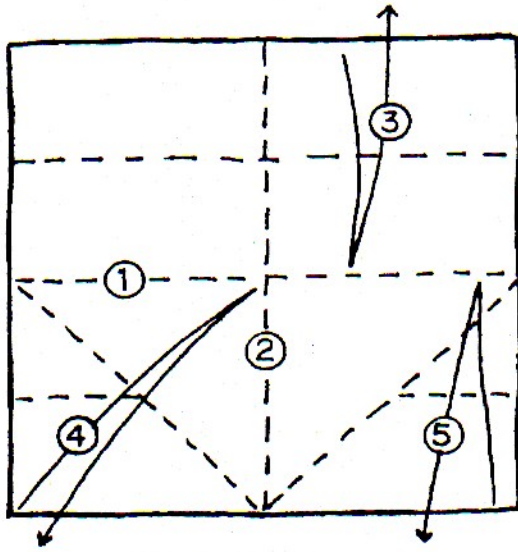

1 White side up.  
Pre-crease accordingly.

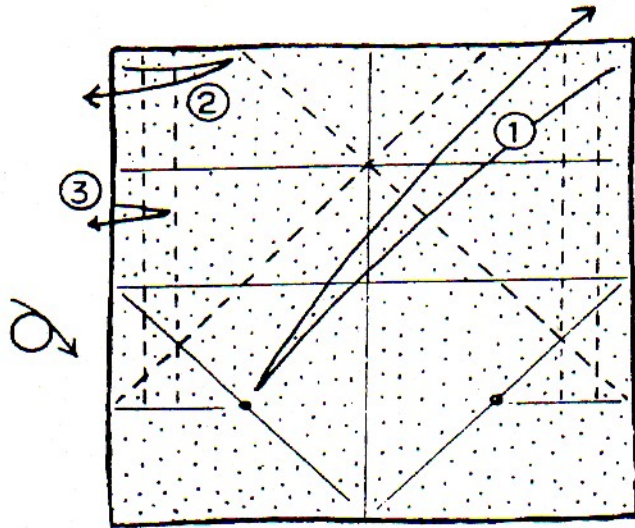

2 Add in the creases  
accordingly.

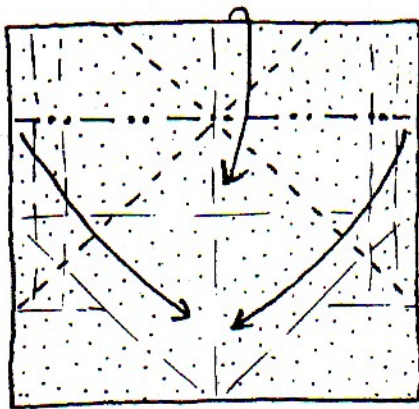

3 Off-set  
Waterbomb Base.

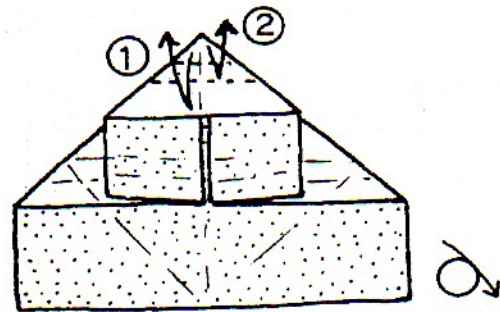

4 Pre-crease, unfold  
and turn over.

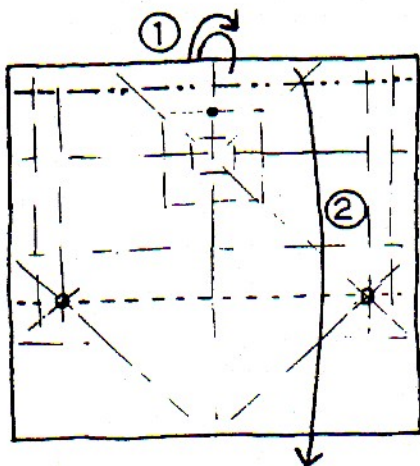

5 1. Pre-crease.  
2. Fold down (note location).

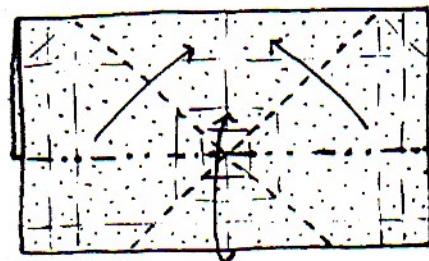

6 Refold the off-set Waterbomb  
Base on the top layer only.

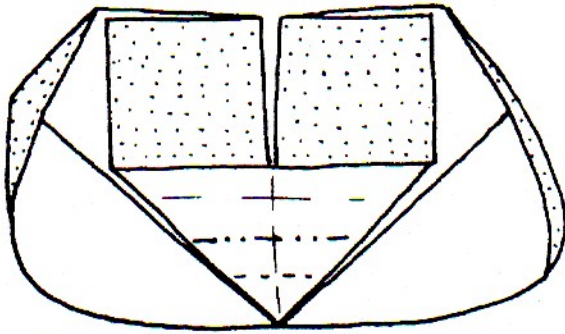

7

Double sink.

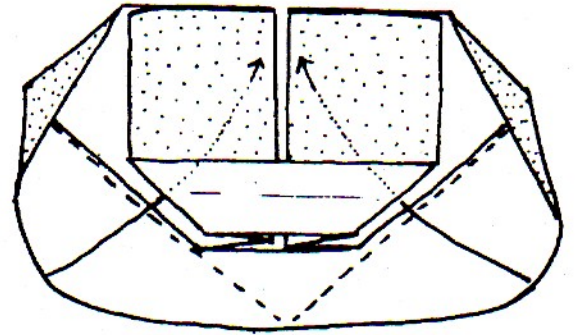

8

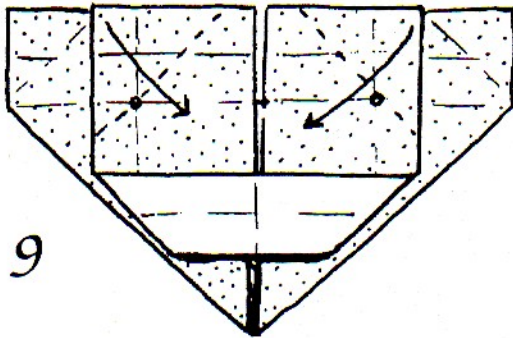

9

Note the location points.

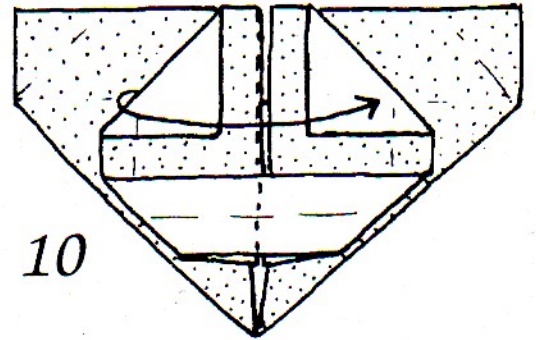

10

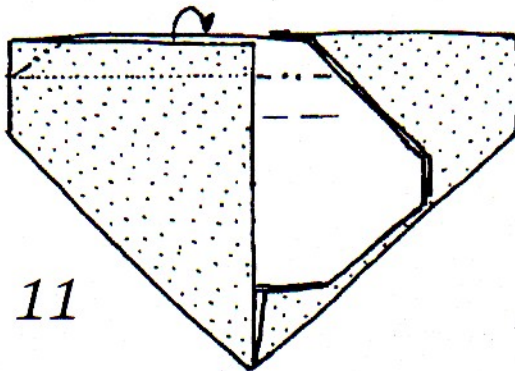

11

Mountain-fold  
the bottom layer.

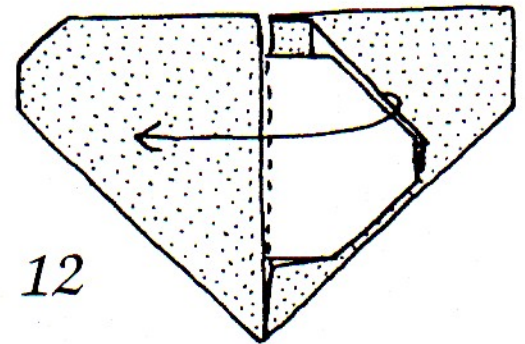

12

Fold the 2 flaps to the left,  
repeat step 11 and  
return 1 flap to the right.

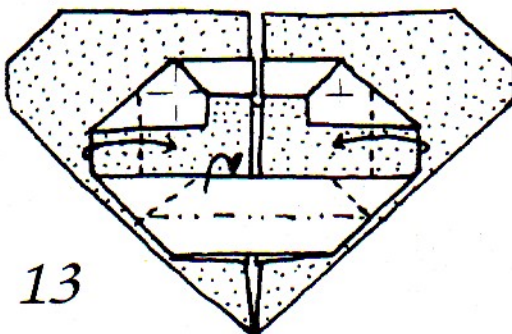

13

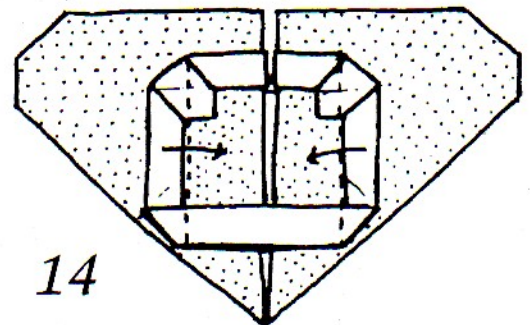

14

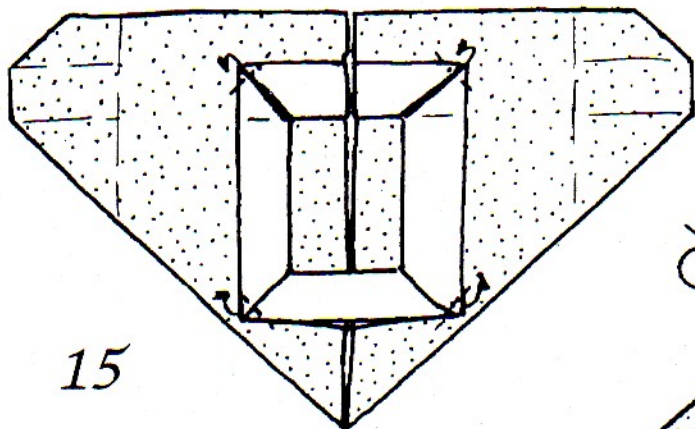

15

Round off.

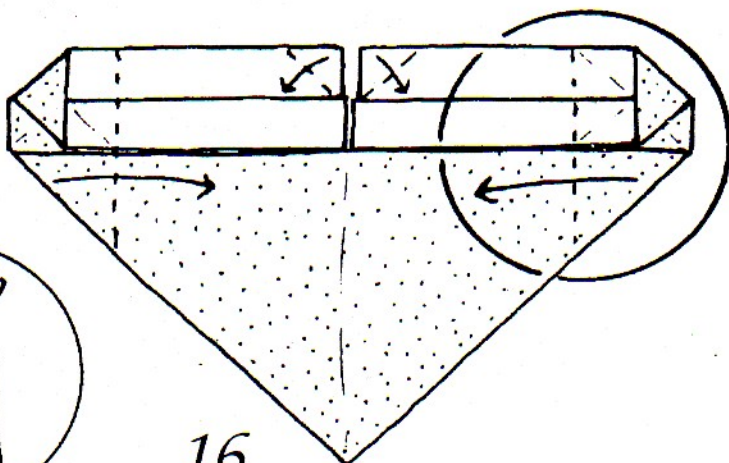

16

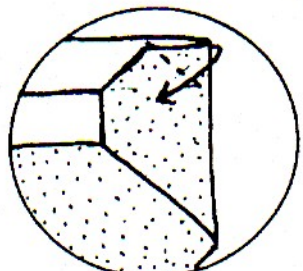
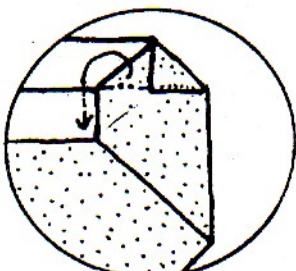

17

18 Repeat steps 16 to 18 for the left side.

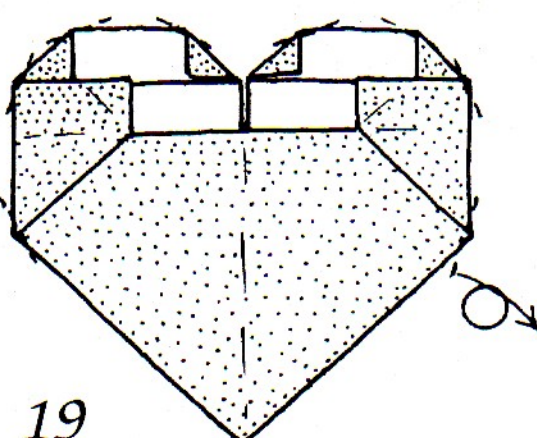

19

Round off to shape the heart.

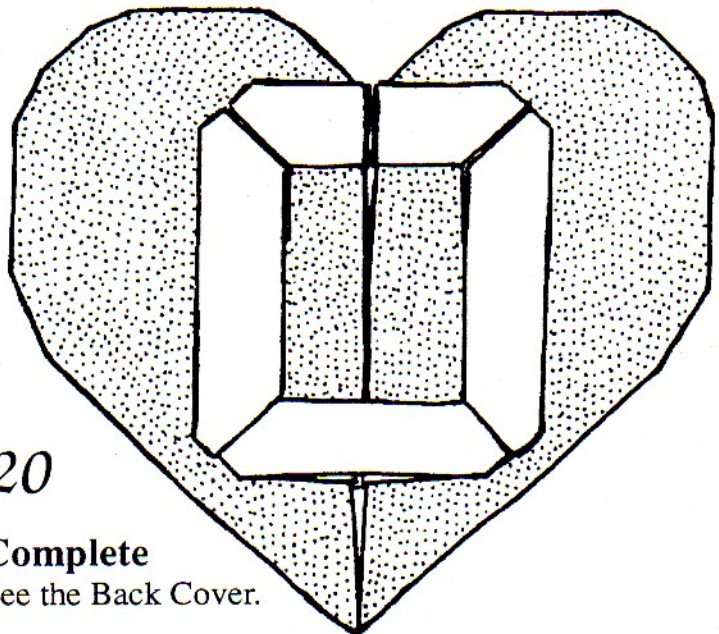

20

Complete  
See the Back Cover.

# Heart 4

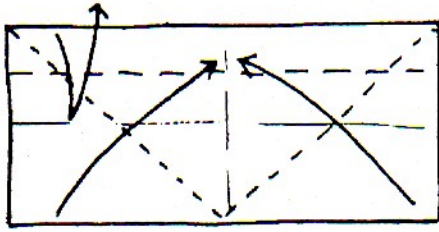

1 2 × 1 rectangle.  
White side up.

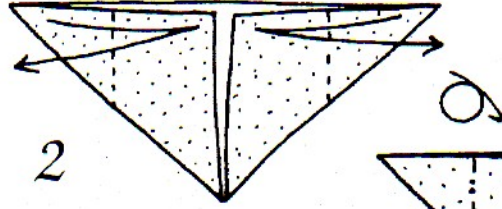

2

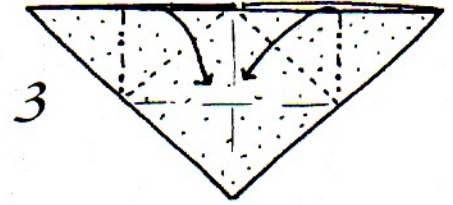

3

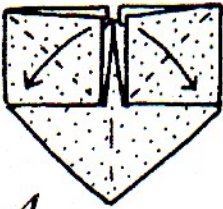

4

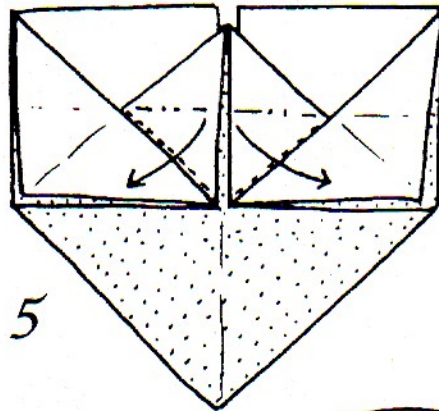

5

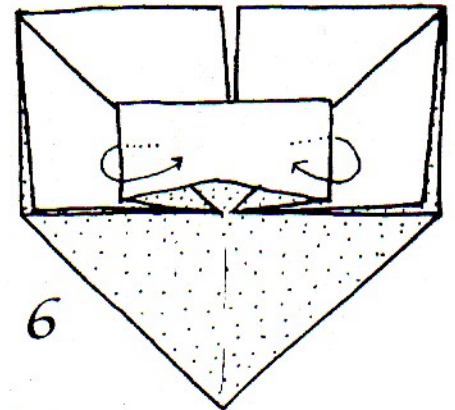

6

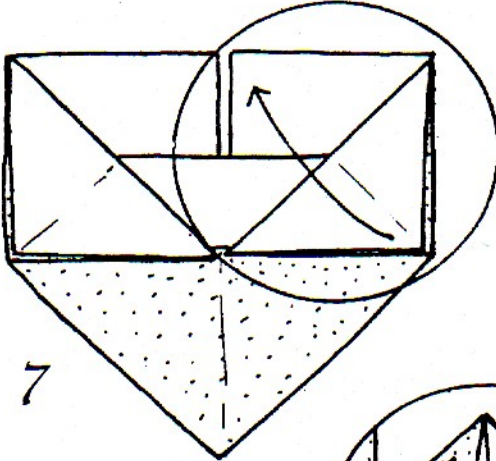

7

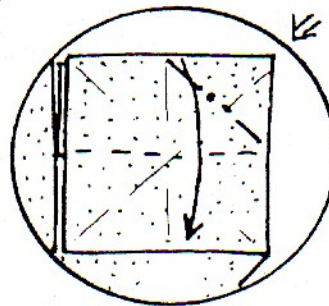

8

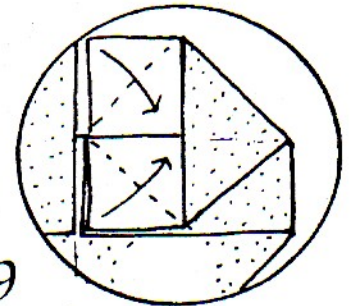

9

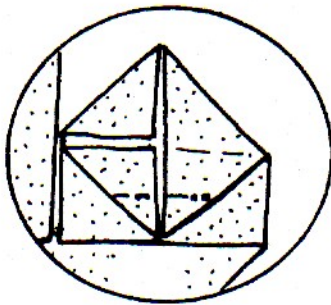

10 Sink.

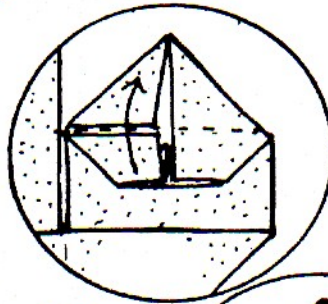

11

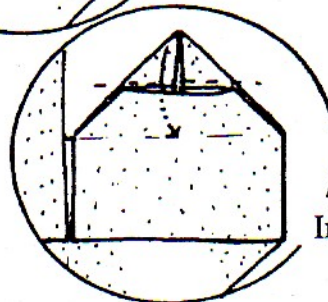

12

Insert.

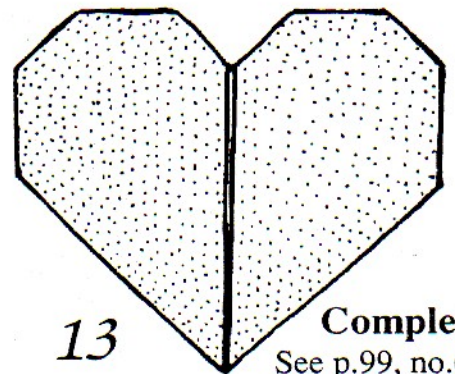

13

**Complete**  
See p.99, no.69

# 2-Piece Heart Coaster

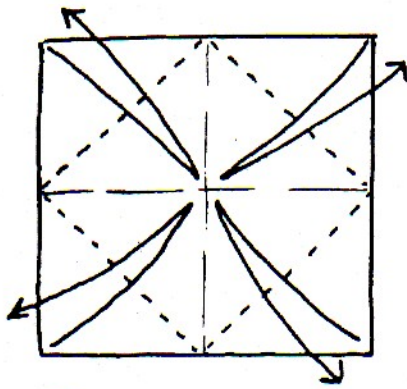

1 White side up.  
Pre-crease.

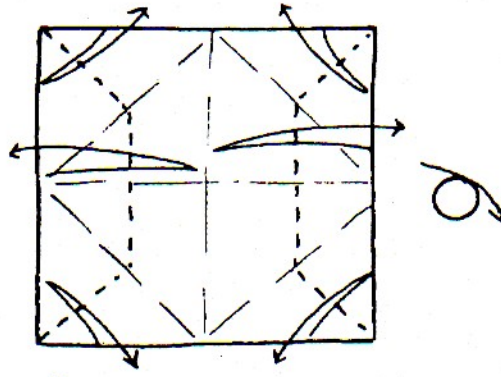

2 Pre-crease.  
Do not crease beyond.

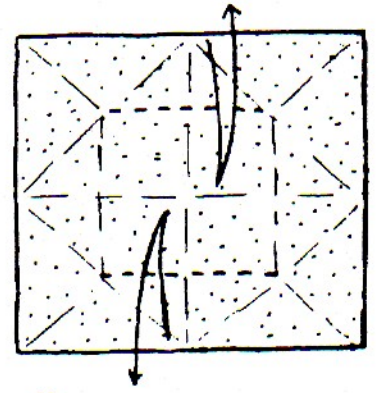

3

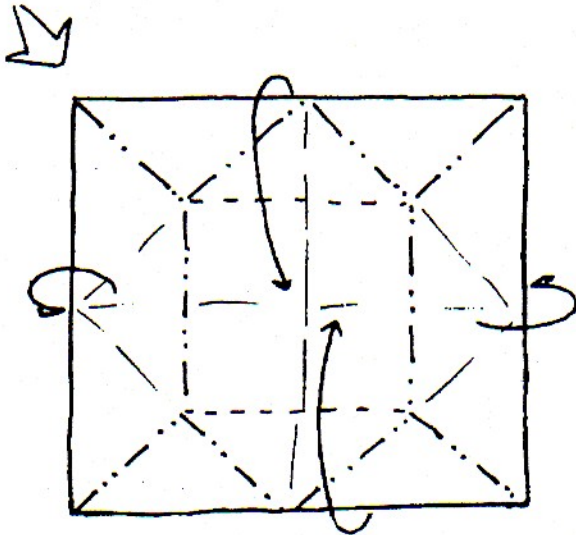

4 Color side up.

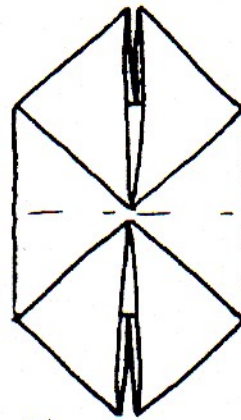

5

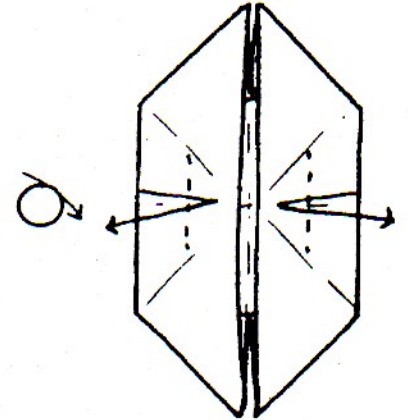

6

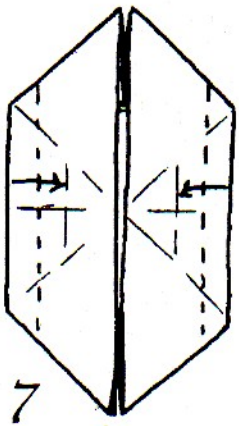

7

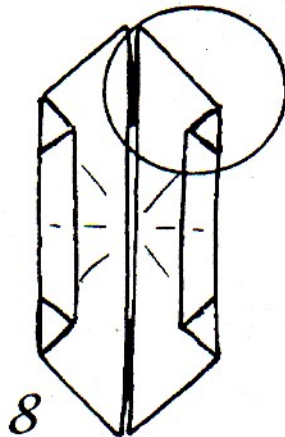

8

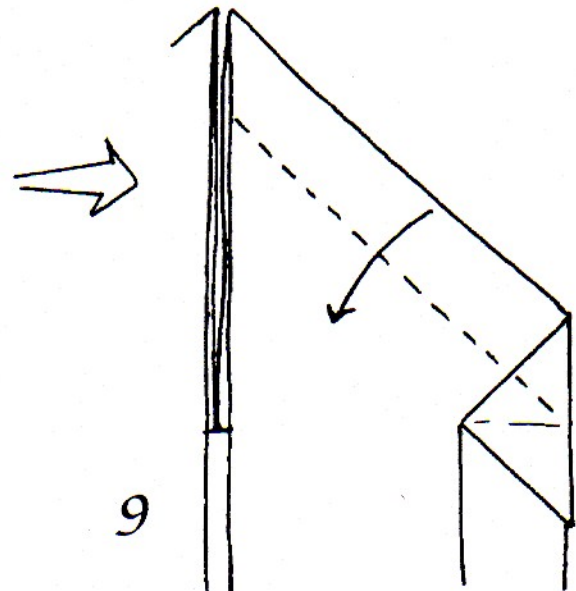

9



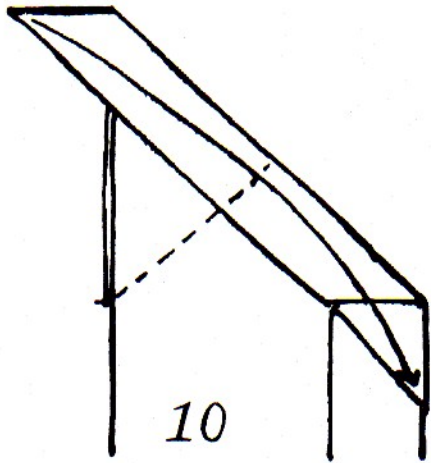

10

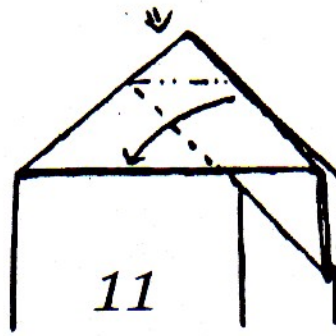

11

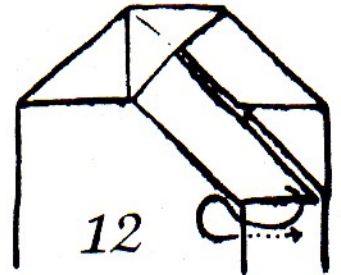

12

Tuck under.

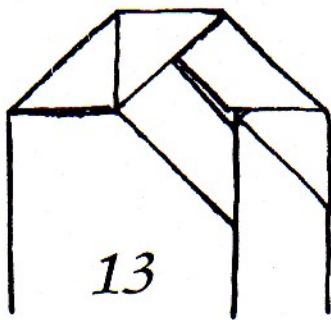

13

Repeat steps 9 to 12  
for the 3 other flaps.

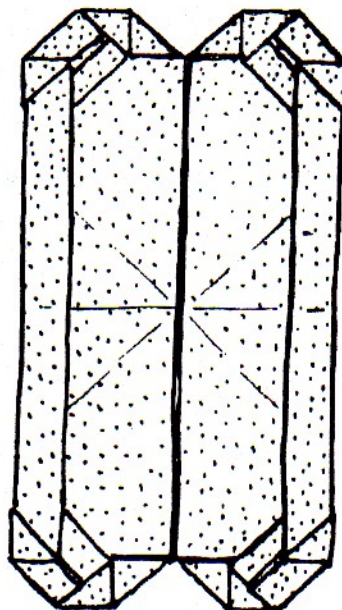

14

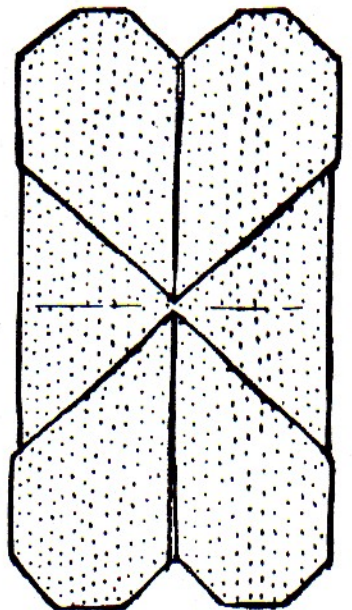

15

**Assembly**

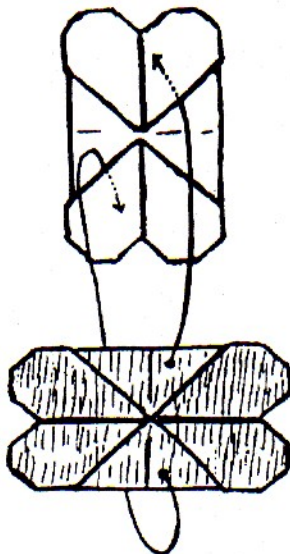

Insert.

Make one more unit  
and assemble as shown.

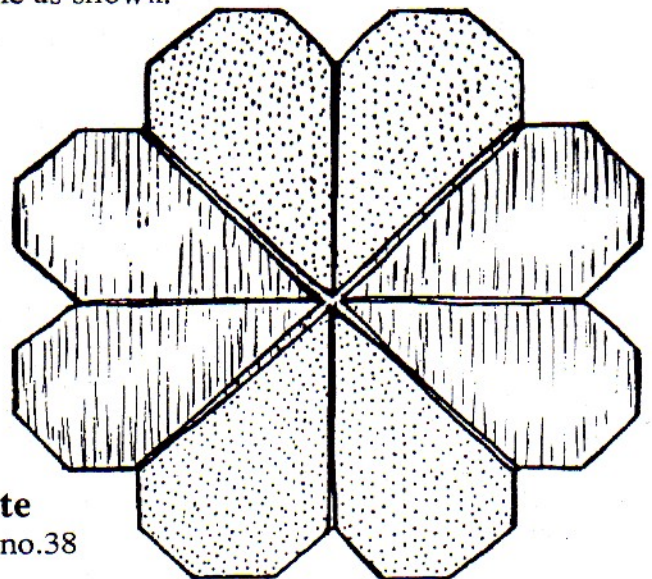

16

**Complete**  
See p.12, no.38